

GENERAL NOTE

The Transport Planning and Design Manual (the TPDM) consists of eleven volumes and is published primarily as a working document for Transport Department staff. It also provides information and guidance to others involved in the planning and design of transport infrastructures in Hong Kong.

It is intended that the information contained herein will be periodically revised to take account of the most up-to-date knowledge and experience. The inevitable time-lag however, means that certain sections may at a particular time be unavoidably not up-to-date. For this and other reasons, the standards contained in this manual should not be followed rigidly but rather treated as a framework within which professional judgment should be exercised to reach an optimum solution.

Generally speaking, the standards contained in the TPDM generally apply to new traffic and transport facilities and should not be considered as exhaustive. Situation may arise for which considerations and requirements are not fully covered by the TPDM. Practitioners are particularly required to exercise professional judgement when dealing with existing facilities that are subject to site constraints, and to endeavour to take into account the views from stakeholders. Practitioners are also advised to make reference to other publications relevant to their designs such as the latest legislations, code of practices, guidelines, datasets, etc. before applying the TPDM.

Transport Planning & Design Manual

VOLUME 2 - Highway Design Characteristics

- Chapter 1 - Introduction
 - 1.1 Purpose
 - 1.2 Contents of Volume 2
- Chapter 2 - Vehicle Dimensions and Design Flows
 - 2.1 References
 - 2.2 Vehicle Dimensions
 - 2.3 Passenger Car Units
 - 2.4 Design Flow Characteristics
- Chapter 3 - Road Characteristics
 - 3.1 References
 - 3.2 Road Types
 - 3.3 Road Alignment
 - 3.4 The Road in Cross Section
 - 3.5 Highway Clearances
 - 3.6 Run-ins and Footway Crossings
 - 3.7 Pedestrian Crossing Facilities
 - 3.8 Cycle Tracks
 - 3.9 Railings, Barrier Fences and Crash Cushions
 - 3.10 Road Tunnels
 - 3.11 Single Track Access Roads
 - Annex
- Chapter 4 - Junctions
 - 4.1 References
 - 4.2 Junction Design - General
 - 4.3 Priority Junctions
 - 4.4 Traffic Signals
 - 4.5 Roundabouts
 - 4.6 Grade Separated Junctions
 - Appendix
- Chapter 5 - Other Facilities
 - 5.1 References
 - 5.2 Introduction
 - 5.3 Petrol Filling Stations in relation to Highway Design
 - 5.4 Additional Speed Control Facilities
 - 5.5 Public Transport On-street Stopping Places
 - 5.6 Landscaping
 - 5.7 Lighting and Drainage
- Chapter 6 - Expressways
 - 6.1 References
 - 6.2 Introduction
 - 6.3 Expressway Design Standards
 - 6.4 Permanent Signs and Road Markings
 - 6.5 Lane and Carriageway Closures
 - 6.6 Maintenance Operations Centres (MOC)
 - 6.7 Service Areas
 - 6.8 Operation and Management

TPDM Volume 2 Chapter 1 – Introduction

1.1 Purpose

1.1.1 Volume 2

- 1.1.1.1 The purpose of Volume 2 of the Transport Planning and Design Manual is to provide Highway Design Characteristic Criteria appropriate for use in the Territory.
- 1.1.1.2 Whilst every effort has been made to include most subjects relevant to the design of highways and is based on the most recent information available, research on these subjects is a continuing process and it will be necessary to expand and update information from time to time.
- 1.1.1.3 The criteria contained in this Volume are intended to be used as guide lines and not, unless otherwise stated, as standards to be rigidly adhered to. At all times a flexible approach should be adopted producing economic design commensurate with safety and practical considerations.

1.1.2 Highway Design Characteristics

- 1.1.2.1 Highway Design Characteristics as used in the context of this volume are intended to deal generally with layout design, rather than construction design. The latter should be dealt with in technical guidelines prepared by the Highways Department or other works departments.
- 1.1.2.2 There is obviously an interrelationship between design parameters for the layout of any scheme and the construction of it. This Volume had been prepared in consultation with the Highways Department and has taken into account those characteristics of construction which have been found to influence layout design.
- 1.1.2.3 The criteria given in the various Chapters of this Volume will generally produce acceptable designs, though in the case of difficult site constraint, some deviations from the criteria may be necessary. When major deviations from the recommended criteria are contemplated, the designer should carefully examine the consequent impact on road safety. These major deviations should also be promptly brought to the attention of the appropriate authorities by the designer, with justifications and supporting mitigation measures to counter the anticipated pitfalls from the recommended criteria. The designer must obtain approval from the appropriate authorities for any major deviation. If there is any doubt as to what constitutes a major deviation, advice from the appropriate authorities should be sought.
- 1.1.2.4 The qualifying term "desirable maximum", "desirable minimum", "absolute maximum" or "absolute minimum" is frequently used in this Volume. When adopting the desirable maximum/minimum criteria recommended in this Volume, one can generally achieve a desirable level of performance in terms of traffic safety. However, there are circumstances that warrant the adoption of a less forgiving design due to severe site constraints or to avoid disproportionately high construction and maintenance cost. In such circumstances, the designer may adopt some intermediate design criteria between the desirable and the absolute maximum/minimum. In more complicated cases that exceptional difficulty is encountered such that the absolute thresholds recommended in this Volume become not achievable, such deviations shall be regarded as major deviations and the designer is responsible for justifying such design is safe with substantiations and supporting mitigation measures. Approval for major deviations must be obtained from the appropriate authorities.

1.2 Contents of Volume 2

1.2.1 General

1.2.1.1 Volume 2 is composed of six Chapters, i.e. Introduction, Vehicle Dimensions and Design Flows, Road Characteristics, Junctions, Ancillary Aspects Affecting & Highways Design, including adjacent public transport facilities and filling stations and Expressways.

1.2.2 Chapter 2 - Vehicle Dimensions and Design Flows

1.2.2.1 This is divided into four sections as follows :

- 1) References
- 2) Vehicle Dimensions, including permissible gross vehicle weights, and information on the turning circles of vehicles
- 3) Passenger Car Units
- 4) Design Flow Characteristics

1.2.3 Chapter 3 - Road Characteristics

1.2.3.1 This is divided into ten sections as follows :

- 1) References
- 2) Road Types
- 3) Road Alignment
- 4) The Road in Cross Section
- 5) Highway Clearances
- 6) Run-ins and Footway Crossings
- 7) Pedestrian Crossing Facilities
- 8) Cycle Tracks
- 9) Railings and Barrier Fences
- 10) Road Tunnels
- 11) Single Track Access Road

1.2.4 Chapter 4 - Junctions

1.2.4.1 Chapter 4 is divided into six section which are as follows :

- 1) References
- 2) Junction Design (General)
- 3) Priority Junctions
- 4) Signal Control Junctions (General)
[The design of signal installations is however contained in Volume 4]
- 5) Roundabouts
- 6) Grade separated Junctions

1.2.5 Chapter 5 - Other Facilities

1.2.5.1 Chapter 5 deals with the aspects of Highway Design affected by the provision of adjacent facilities for public transport and petrol filling stations.

1.2.5.2 General policy on public transport and detailed design of bus termini and transport interchanges will however be found by reference to Volume 9.

1.2.5.3 Details as to Highway layouts in respect of public transport priority schemes will be found in Volume 6 - Traffic and Environmental Management.

1.2.6 Chapter 6 - Expressways

1.2.6.1 This is divided into ten sections as follows :

- 1) References
- 2) Introduction
- 3) Expressway Design Standards
- 4) Permanent Signs and Road Markings
- 5) Lane and Carriageway Closures
- 6) Signing and Marking of Works Vehicles
- 7) Road Maintenance Operations
- 8) Maintenance Operations Centres (MOC)
- 9) Services Areas
- 10) Operation and Management

TPDM Volume 2 Chapter 2 – Vehicle Dimensions and Design Flows

2.1 References

1. Road Traffic (Construction and Maintenance of Vehicles) Regulations 1984
2. T.R.R.L. Report LR 608 "Road Width Requirements of Commercial Vehicles"
3. Technical Memorandum H9/76 D.O.E. "Design Flows for Urban Roads"
4. Technical Memorandum H6/74 D.O.E. "Design Flows for Motorway and Rural All-purpose Roads"
5. T.T.S.D. Data Record 92 - Public Light Buses. Effect on Traffic Flow (No. 18)
6. The Future of the H.K. Tramway System, C.E.O.
7. SCHNEIDER UNTERSUCHUNG UBER DIE BORDSTEINFUHRUNG BEI DER EMMUNDUNG STADTISCHER STRASSEN STRASSE UND AUTOBAHN NO. 6 VO 14 JUNE 1963
8. Predication of Vehicle Swept Paths by G.J. HILL. The Highway Engineer December 1978
9. Departmental Standard TD 9/93. Road Layout and Geometry: Highway Link Design. U.K. Department of Transport
10. The Government of the HKSAR Transport Department: Third Comprehensive Transport Study

2.2 Vehicle Dimensions

2.2.1 Statutory Dimensions

2.2.1.1 The Road Traffic (Construction and Maintenance of Vehicles) Regulations, effective from August 1984, contain maximum dimensions for vehicles which are shown in Table 2.2.1.1.

2.2.1.2 Table 2.2.1.2 shows the maximum weight of vehicles for the new legislation and Tables 2.2.1.4 - 2.2.1.7 show how these are qualified.

2.2.1.3 The maximum permissible weights transmitted to the road surface, also contained in the Regulations, are as follows :

- (i) For one wheel, where no other wheel is in the same line transversely, not greater than 4.5 tonnes
- (ii) For two wheels in the same line transversely, not greater than 9 tonnes
- (iii) For two wheels in the same line transversely, if each wheel is fitted with 2 pneumatic tyres not greater than 10 tonnes.
- (iv) For more than 2 wheels in the same line transversely, not greater than 11 tonnes.

2.2.1.4 Maximum swept turning circles for vehicles given in the Road Traffic (Construction and Maintenance) Regulations are shown in Table 2.2.1.8.

2.2.1.5 Under the legislation the Commissioner also has powers to license vehicles in excess of the dimensions or weights shown in the tables.

Table 2.2.1.1
Overall Dimensions of Vehicles

<u>Vehicle</u>	<u>Overall Length(m)</u>	<u>Overall Width(m)</u>	<u>Overall Height(m)</u>
Private Car	6.3	2.3	2
Taxi	6.3	2.3	2
Invalid Carriage	6.3	2.3	2
Light Bus	7.5	2.3	3
Bus			
(i)Single Deck	12	2.5	3.5
(ii)Double Deck	12	2.5	4.6
Articulated	15	2.5	3.5
Light Goods Vehicle	10	2.5	3.5
Medium Goods Vehicle	11	2.5	4.6
Heavy Goods Vehicle			
(i)Rigid	11	2.5	4.6
(ii)Articulated	16	2.5	4.6
Special Purpose Vehicle	12	2.5	4.6
Tricycle	-	1.1	-
Trailer	13.5	2.5	4.6
Pedestrian-controlled Vehicle	4.3	1.6	-

Table 2.2.1.2
Maximum Weights of Vehicles

<u>Class of Vehicle</u>	<u>Maximum Gross Vehicle Weights(tonnes)</u>
Private Car	3
Taxi	3
Invalid Carriage	3
Light Bus	8.5
Bus	24
Light Goods Vehicle	5.5
Medium Goods Vehicle	24
Heavy Goods Vehicle	38
Motor Cycle	0.5
Motor Tricycle	0.6
Trailer	38

Table 2.2.1.3
Maximum Weights for Rigid Vehicles

<u>Class of Rigid Vehicle</u>	<u>Wheel Span Measurement(m)</u>	<u>Maximum Gross Vehicle Weights (tonnes)</u>
2 axled vehicle	Less than 2.65	14
	At least 2.65	16
3 axled vehicle	Less than 3	16
	At least 3	18
	At least 3.2	20
	At least 3.9	22
	At least 4.9	24
4 axled vehicle	Less than 3.7	18
	At least 3.7	20
	At least 4.6	22
	At least 4.7	24
	At least 5.6	26
	At least 5.9	28
	At least 6.3	30

Table 2.2.1.4
Maximum Weights for Articulated Vehicles

<u>Class of Motor Vehicle</u>	<u>Wheel Span Measurement(m)</u>	<u>Maximum Gross Vehicle Weight(tonnes)</u>
2 axled motor vehicle	Less than 2.4	14
	At least 2.4	16
3 axled motor vehicle	Less than 3	18
	At least 3	20
	At least 3.8	22
	At least 4.3	24
<u>Class of Semi-trailer</u>	<u>Distance between 2 closely spaced axles(m)</u>	<u>Maximum Gross Axle Weight for 2 closely spaced axles(tonnes)</u>
2 axled semi-trailer	Less than 1.02	11
	At least 1.02	16
	At least 1.05	17
	At least 1.2	18
	At least 1.5	19
	At least 1.85	20
	<u>Distance between outer axles of 3 closely spaced axles(m)</u>	<u>Maximum Gross Axle Weight for 3 closely spaced axles(tonnes)</u>
3 axled semi-trailer	Less than 1.4	10.5
	At least 1.4	12
	At least 1.5	18
	At least 2	19.5
	At least 2.55	21
	At least 2.7	22.5

"2 closed spaced axles" means axles that are spaced at a distance apart of not more than 2.5 metres and not less than 1 metre.

"3 closed spaced axles" means the outermost axles that are spaced at a distance apart of 3.25 metres or less.

Table 2.2.1.5
Maximum Combined Weights for Articulated Vehicles

<u>Type of Combination of Articulated Vehicle</u>	<u>Inner Axle Spacing(m)</u>	<u>Maximum Gross Combined Weight(tonnes)</u>
2 axled motor vehicle with 1 axled trailer	Less than 2.1	20
	At least 2.1	22
	At least 3.1	24
2 axled motor vehicle with 2 axled trailer	Less than 2.9	24
	At least 2.9	26
	At least 3.1	29
	At least 3.6	32
	At least 4	34
2 axled motor vehicle with 3 or more axled trailer	At least 4.2	38
3 or more axled motor vehicle with 1 axled trailer	Less than 2	22
	At least 2	24
	At least 2.7	26
	At least 3	28
	At least 4	30
3 or more axled motor vehicle with 2 or more axled trailer	Less than 2	24
	At least 2	26
	At least 2.3	30
	At least 3.2	34
	At least 4	38
3 or more axled motor vehicle with 2 or more axled trailer	At least 4.7	40
	At least 5.2	42
	At least 5.7	44

"inner axle spacing" means the distance between the rearmost axle of a motor vehicle and the foremost axle of the trailer.

Table 2.2.1.6
Maximum Weights for 2 Closely Spaced Axles

<u>Distance between 2 closely spaced axles(m)</u>	<u>Maximum Axle Weight for any one axle(tonnes)</u>
Less than 1.02	5.5
At least 1.02	8
At least 1.05	8.5
At least 1.20	9
At least 1.50	9.5
At least 1.85	10

"2 closely spaced axles" means axles that are spaced at a distance apart of not more than 2.5 m and not less than 1.02 m.

Table 2.2.1.7
Maximum Weights for 3 Closely Spaced Axles

<u>Column 1</u> Distance between outer axles of 3 closely spaced axles(m)	<u>Column 2</u> Maximum Axle Weight for any one axle(tonnes)
Less than 1.4	3.5
At least 1.4	4
At least 1.5	6
At least 2	6.5
At least 2.55	7
At least 2.7	7.5

"3 closely spaced axles" means the outermost axles that are spaced at a distance apart of 3.25 metres or less.

Table 2.2.1.8
Maximum Swept Turning Diameters

<u>Vehicle length</u>	<u>Maximum Swept Turning Diameter</u>
not greater than 10m	24.5m
greater than 10m	26m

2.2.2 Typical Dimensions

2.2.2.1 For design purposes typical dimensions for vehicles should be in accordance with Table 2.2.2.1, which are in part based on maximum vehicle lengths permitted under the Road Traffic (Construction and Maintenance of Vehicles) Regulations taking into account dimensions for vehicles shown in Tables 2.2.2.2, 2.2.2.3 and 2.2.2.4

Table 2.2.2.1
Design Dimensions

<u>Type of Vehicle</u>	<u>Length(m)</u>	<u>Width(m)</u>	<u>Height(m)</u>
Car	4.6	1.7	1.5
Light Goods Vehicle	5.2	2.1	1.6
Medium Goods Vehicle	11	2.5	4
Heavy Goods Vehicle	16	2.5	4.6
Articulated Container Vehicles	16	2.5	4.6
Bus	12	2.5	3.5 Single deck 4.6 Double deck
Light Bus	7.5	2.3	3

- Notes :
- (i) The above dimensions are not necessarily maximum dimensions.
 - (ii) Container vehicles up to 18.9m have been licensed.

2.2.2.2 Typical dimensions of certain different types of vehicles are shown in Tables 2.2.2.2, 2.2.2.3 and 2.2.2.4

Table 2.2.2.2
Vehicle Dimensions - Private Cars

<u>Vehicle Make</u>	<u>Length</u> (m)	<u>Width</u> (m)	<u>Height</u> (m)	<u>L1</u> (m)	<u>L2</u> (m)	<u>L3</u> (m)	<u>W1</u> (tonnes)	<u>W2</u> (tonnes)	<u>Unladen</u> <u>Weight</u> (tonnes)	<u>Max</u> <u>G.V.W.</u> (tonnes)	<u>Turning</u> <u>Diameter</u> <u>Swept</u> (m)
Mercedes Benz S55	5.038	1.855	1.450	0.867	2.965	1.206			1.830	2.400	11.7
Mercedes Benz C320	4.526	1.728	1.427	0.755	2.715	1.056			1.490	2.045	10.7
Mercedes Benz S600	5.158	1.855	1.447	0.867	3.085	1.206			1.880	2.460	11.7
Mercedes Benz C200	4.343	1.728	1.406	0.788	2.715	0.840			1.540	2.050	10.7
Jaguar Daimler V8	5.148	1.798	1.375	0.914	2.995	1.239			1.845	2.260	12.4
Jaguar Daimler XKR	4.760	1.829	1.306	0.972	2.588	1.20			1.735	2.010	11.0
Jaguar S-TYPE	4.876	1.819	1.441	0.854	2.909	1.097			1.733	2.190	12.1
AUDI S8	5.034	1.880	1.438	1.011	2.887	1.136			1.750	2.350	12.3
AUDI A6	4.833	1.850	1.448	1.006	2.758	1.069			1.750	2.290	11.7
Honda Civic	4.435	1.720	1.440	0.805	2.620	1.010			1.110	1.580	10.8
Honda Accord	4.795	1.785	1.455	0.975	2.715	1.105			1.490	1.905	11.0
Honda S2000	4.135	1.750	1.285	0.805	2.405	0.930			1.240	1.350	10.8
Volvo S80	4.822	1.832	1.452	0.964	2.791	1.067			1.506	1.531	11.2
Volvo V40	4.516	1.716	1.460	0.912	2.562	1.043			1.367	1.780	10.6
Volkswagen Bora	4.374	1.735	1.445	0.874	2.513	0.987			1.261	1.800	10.9
Mitsubishi Lancer	4.455	1.770	1.450	0.895	2.625	0.935			1.400	1.695	9.8
Mitsubishi Lancer MX5	4.370	1.695	1.430	0.850	2.600	0.920			1.140	1.600	9.8

L1 = Distance between front and front axle

L2 = Distance between axles

L3 = Distance between rear axle and rear

Table 2.2.2.3
Vehicle Dimensions - Light Goods Vehicles

<u>Vehicle Make</u>	<u>Length(m)</u>	<u>Width(m)</u>	<u>Height(m)</u>	<u>L1(m)</u>	<u>L2(m)</u>	<u>L3(m)</u>	<u>W1</u> (tonnes)	<u>W2</u> (tonnes)	<u>Unladen</u> <u>Weight</u> (tonnes)	<u>Max</u> <u>G.V.W.</u> (tonnes)	<u>Turning</u> <u>Diameter</u> <u>Swept</u> (m)
Mercedes-Benz 416CDI	6.590	1.988	2.610	0.939	4.025	1.625	1.750	3.200	2.360	4.600	14.3
Mercedes-Benz 312D	6.535	1.933	2.570	0.882	4.025	1.480	1.600	2.240	2.050	3.500	14.3
Nissan Caravan	4.690	1.690	1.950	0.980	2.645	1.040	1.350	1.680	1.550	2.965	10.8
Nissan E24	4.790	1.690	1.990	1.100	2.645	1.045	1.350	1.680	1.605	2.750	10.8
Mitsubishi L300	4.805	1.690	1.960	1.280	2.435	1.090	1.200	1.450	1.370	2.505	9.8
Volswagon LT46	6.535	1.994	2.610	0.855	4.025	1.625	1.750	3.200	2.302	4.600	14.3
Volswagon LT35	5.585	1.993	2.570	0.885	3.550	1.150	1.600	2.240	1.895	3.500	12.8

Where L1 = Distance between front and front axle

L2 = Distance between axles

L3 = Distance between rear axle and rear

W1 = Maximum axle load, front axle

W2 = Maximum axle load, rear axle

Table 2.2.2.4
Vehicle Dimensions - Light Buses

<u>Vehicle Make</u>	<u>Length</u> (m)	<u>Width</u> (m)	<u>Height</u> (m)	<u>L1</u> (m)	<u>L2</u> (m)	<u>L3</u> (m)	<u>W1</u> (tonnes)	<u>W2</u> (tonnes)	<u>Unladen</u> <u>Weight</u> (tonnes)	<u>Max</u> <u>G.V.W.</u> (tonnes)	<u>Turning</u> <u>Diameter</u> <u>Swept</u> (m)
Toyota BB43R-ZCMSW	6.255	2.025	2.665	1.150	3.200	1.920	1.840	2.620	3.290	4.000	12.5
Mitsubishi BE639ERM HDA	6.245	2.010	2.630	0.940	3.490	1.820	1.830	2.920	3.500	4.000	12.2
Mercedes-Benz 316 CDI	5.640	1.933	2.450	0.939	3.550	1.149	1.600	2.240	2.440	3.500	12.8
Volkswagen LT-35	6.535	1.933	2.670	0.885	4.025	1.625	1.600	2.240	2.690	3.500	14.3
Toyota BB43R - ZEMSW	6.255	2.025	2.600	1.150	3.200	1.908	1.840	2.620	3.270	4.000	13.6
Toyota BB50R - ZEMQZ	6.990	2.025	2.600	1.150	3.935	1.905	2.260	3.080	3.450	4.800	15.8
Toyota BZB40R - ZCMSC	6.270	2.035	2.600	1.150	3.200	1.920	1.900	2.620	2.440	4.350	13.6
Toyota BZB50R - ZCMSC5	6.990	2.035	2.520	1.150	3.935	1.905	2.260	3.080	3.530	4.800	15.8
Toyota BZB60R - ZCMSC	6.325	2.080	2.630	1.150	3.200	1.905	2.240	3.340	3.850	5.100	13.6
Toyota XZB70R - ZEMSY	6.990	2.080	2.635	1.150	3.935	1.905	2.450	3.500	3.690	5.400	15.8
Toyota XZB70R - ZEPSY	6.990	2.080	2.703	1.150	3.935	1.905	2.450	3.500	3.750	5.400	15.8
Toyota XZB70R - ZEMQY	6.990	2.080	2.635	1.150	3.935	1.905	2.450	3.500	3.810	5.290	15.8
Toyota BZB70R - ZCMSC5	6.990	2.080	2.703	1.150	3.935	1.905	2.450	3.500	3.670	5.290	15.8
Mit. FUSO BE641GR MDA	6.990	2.010	2.630	0.940	3.995	2.055	2.500	4.800	3.630	5.500	12.8
Mit. FUSO BE641GRM DAD	6.990	2.010	2.630	0.940	3.995	2.055	2.330	3.360	3.760	5.500	12.8
Mit. FUSO BE64DER MDA	6.245	2.010	2.735	0.940	3.490	1.800	2.500	4.800	3.520	5.500	12.8
Mercedes-Benz 516BT EL	7.369	2.000	2.826	1.004	4.340	2.025	2.100	3.600	3.750	5.500	15.3
Golden Dragon XML6701J	6.960	2.072	2.797	1.150	3.930	1.880	2.400	4.500	4.250	5.500	15.8
Ford Transit 2.0 AT LW	5.339	2.032	1.977	1.011	3.300	1.028	1.750	2.015	2.390	3.365	10.9

Where L1 = Distance between front and front axle

L2 = Distance between axles

L3 = Distance between rear axle and rear.

W1 = Maximum axle load, front axle

W2 = Maximum axle load, rear axle

Table 2.2.2.5
Vehicle Dimensions - Medium and Heavy Goods Vehicles

<u>Vehicle Make</u>	<u>Length</u> (m)	<u>Width</u> (m)	<u>Height</u> (m)	<u>L1</u> (m)	<u>L2</u> (m)	<u>L3</u> (m)	<u>L4</u> (m)	<u>L5</u> (m)	<u>W1</u> (tonnes)	<u>W2</u> (tonnes)	<u>W3</u> (tonnes)	<u>W4</u> (tonnes)	<u>Max</u> <u>G.V.W.</u> (tonnes)	<u>Turning</u> <u>Diameter</u> <u>Swept</u> (m)
Mercedes-Benz 2628K	7.405	2.490	2.700	1.440	3.600	1.350	0.750		7.100	9.000	9.000		24.000	17.5
Mercedes-Benz 3234K	8.760	2.500	3.075	1.360	1.696	3.504	1.350	0.630	6.700	6.700	9.000	9.000	30.000	23.0
Mercedes-Benz 1823LNR	9.190	2.490	2.650	1.440	5.400	2.350			6.500	10.00			16.000	20.5
Volvo FL6E42R	10.00	2.490	2.725	1.501	5.800	2.700			7.100	10.00			16.000	18.91
Volvo FM12 6X4	7.460	2.467	2.931	1.365	3.900	1.370	0.825		7.100	9.000	9.000		24.000	15.41
Volvo FL10 8X4	9.289	2.490	2.828	1.419	1.750	3.850	1.370	0.900	7.100	7.100	9.000	9.000	30.000	22.01
Man 25.284 MNLRC	10.12	2.500	2.915	1.620	5.150	1.350	2.00		7.500	7.500	7.500		24.000	20.01
Man 35.364 VFRC	9.869	2.500	3.075	1.525	1.500	4.325	1.400	0.950	7.100	7.100	9.000	9.000	30.00	26.01
Man 15.224LRC	9.700	2.490	2.600	1.225	5.475	3.000			6.000	10.000			16.000	19.01
Hino FY1KUMA	10.74	2.490	2.870	1.410	1.750	3.500	1.350	2.700	6.700	6.700	9.000	30.00		22.5
Hino FS1KTMA	10.33	2.490	2.845	1.410	5.000	1.350	2.535		6.700	9.000	9.000		24.00	21.2
Hino GH1JRKA	9.770	2.360	2.605	1.235	5.800	2.600			6.000	10.000			16.00	21.6
Nissan CWB 47LMNR	7.800	2.490	2.855	1.400	4.350	1.300	1.280		6.000	9.000	9.000		24.00	15.2
Nissan CGB 457SMNR	8.960	2.490	2.910	1.400	1.850	3.150	1.300	1.140	6.000	6.000	9.000	9.000	30.00	18.2
Nissan PK212NHNN	9.530	2.425	2.725	1.280	5.560	2.600			6.000	10.00			16.00	18.8

Where L1 = Distance between front and first axle

L2 = Distance between first and second axle

L3 = Distance between second and third axle

L4 = Distance between third and fourth axle or rear

L5 = Distance between fourth axle and rear

W1 = First axle load

W2 = Second axle load

W3 = Third axle load

W4 = Fourth axle load

Table 2.2.2.6
Vehicle Dimensions - Medium and Tractor Vehicles

<u>Vehicle Make</u>	<u>Length (m)</u>	<u>Width(m)</u>	<u>Height (m)</u>	<u>L1 (m)</u>	<u>L2 (m)</u>	<u>L3 (m)</u>	<u>L4 (m)</u>	<u>L5 (m)</u>	<u>W1 (tonnes)</u>	<u>W2 (tonnes)</u>	<u>W3 (tonnes)</u>	<u>W4 (tonnes)</u>	<u>Max G.V.W. (tonnes)</u>	<u>Turning Diameter Swept (m)</u>
Man 33.464 DFLRT	7.075	2.490	3.250	1.525	3.175	1.400	0.725		8.000	9.000	9.000		24.000	17.00
Man 19.414 FLRT	6.150	2.490	2.850	1.525	3.600	1.025			7.100	10.000			16.000	15.00
Hino SH1KDMA	5.700	2.490	2.825	1.420	3.200	1.080			6.700	10.000			16.000	12.8
Hino SS1KKMA	6.860	2.490	3.235	1.420	3.300	1.350	0.790		6.700	9.000	9.000		24.000	15.8

Where L1 = Distance between front and first axle

L2 = Distance between first and second axle

L3 = Distance between second and third axle

L4 = Distance between third and fourth axle or rear

L5 = Distance between fourth axle and rear

W1 = First axle load

W2 = Second axle load

W3 = Third axle load

W4 = Fourth axle load

2.2.3 Turning Circles

2.2.3.1 Diagrams 2.2.3.1- 2.2.3.8 and 2.2.3.11 show dimensions of turning circles for various types of vehicles.

2.2.3.2 In TRRL Report LR 608 "Road Width Requirements of Commercial Vehicles", calculations as to road widths required for different types of vehicles have been determined.

2.2.3.3 A further means for determining the swept area of a turning vehicle is the "Schneider" method and is summarised in Diagrams 2.2.3.9 and 2.2.3.10. This method determines the turning area of a vehicle by plotting the progressive position of the vehicle and whilst not precise is probably sufficiently accurate for assessing road width requirements. It can be used for any radius of turn.

**DIAGRAM 2.2.3.1 : RECOMMENDED MINIMUM STANDARDS
OF TURNING CIRCLE FOR PRIVATE CARS**

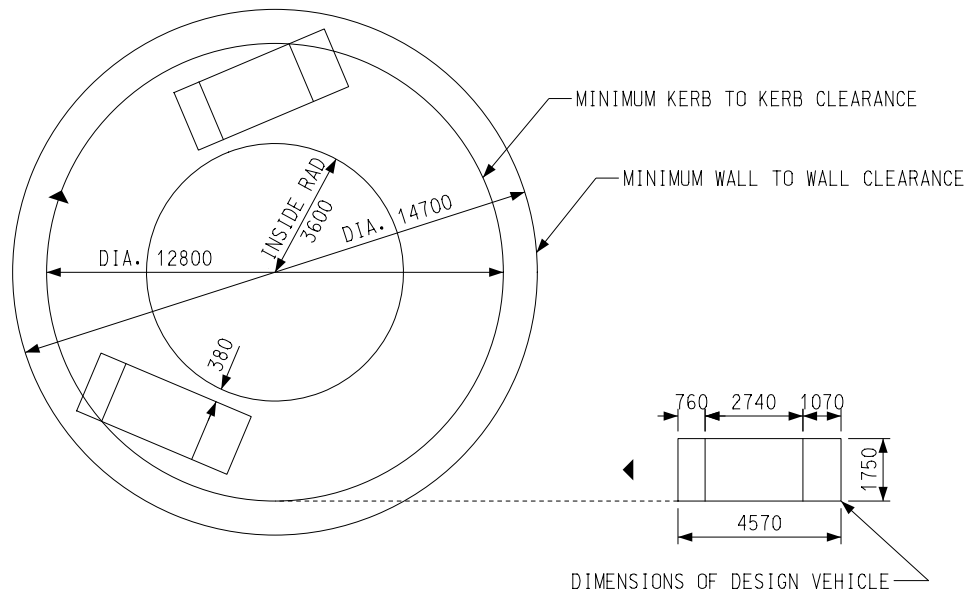
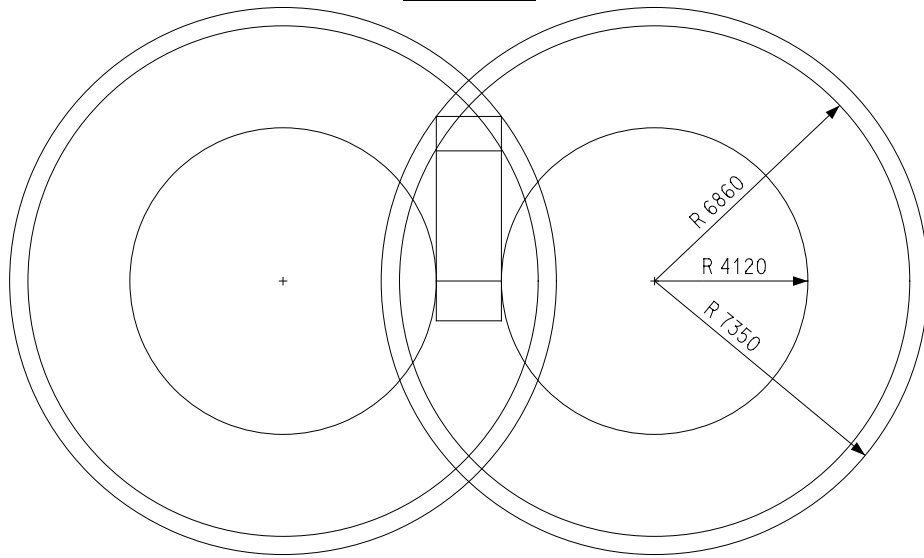
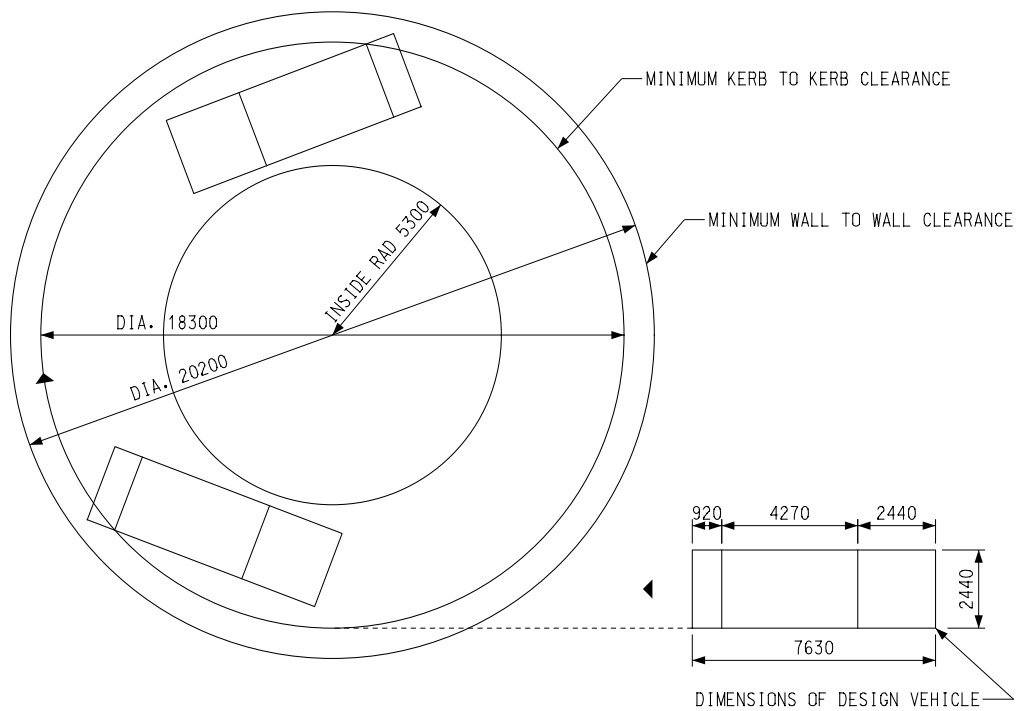

DIAGRAM 2.2.3.2 : TURNING CIRCLE
PRIVATE CAR
(LARGE SIZE)
5.49 x 1.88



NOTE: ALL DIMENSIONS IN METERS

DIAGRAM 2.2.3.3 : RECOMMENDED MINIMUM STANDARDS OF TURNING CIRCLE
AND TURNABLE FOR GOODS VEHICLES
MIN. STANDARD TURNING CIRCLE FOR GOODS VEHICLE



MIN. STANDARD TURNTABLE FOR GOODS VEHICLE

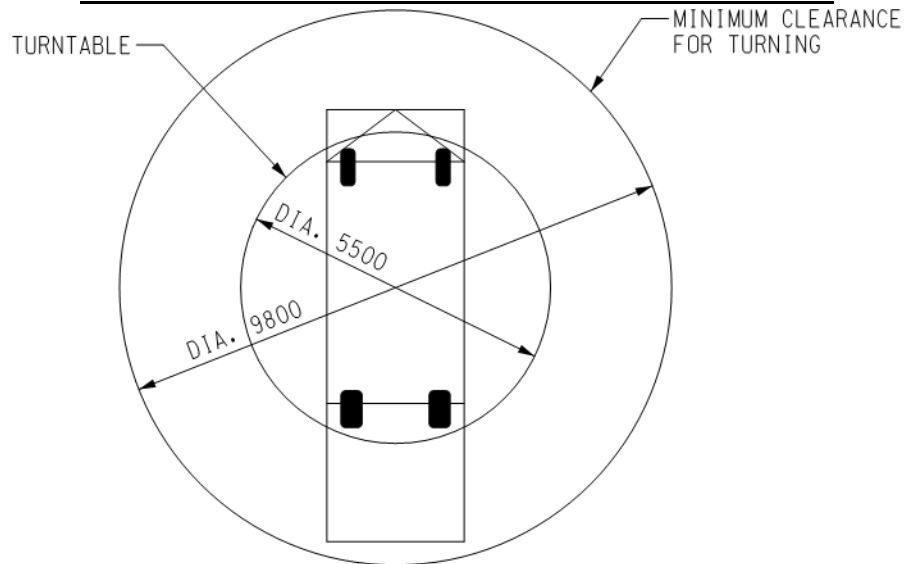

NOTE: ALL DIMENSIONS IN MILLIMETERS

DIAGRAM 2.2.3.4 : CHARACTERISTICS OF LARGER FIRE APPLIANCES

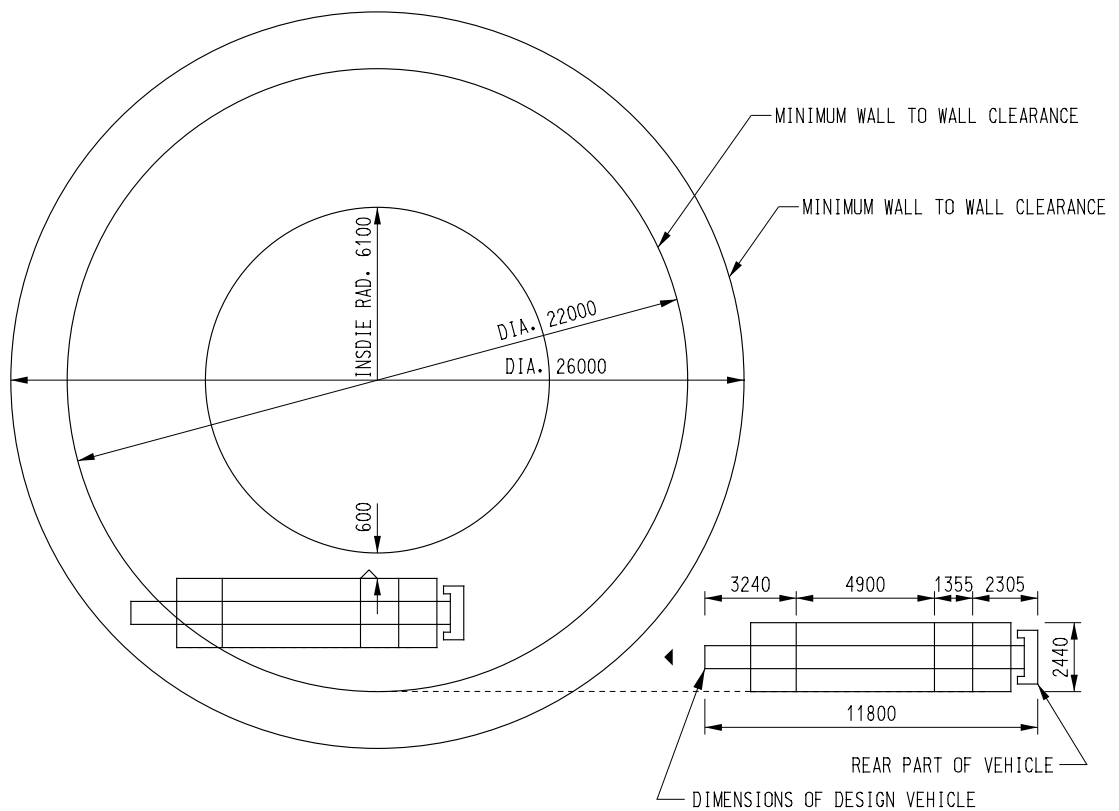

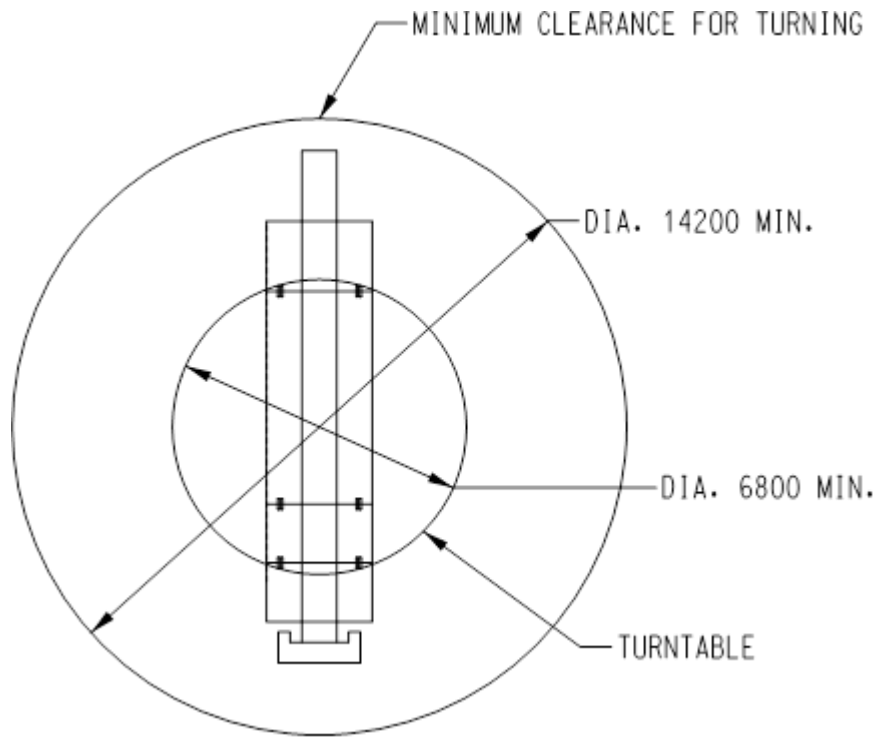

DATA

DESIGN VEHICLE EXTRA HEAVY PUMP

WHEEL BASE (B) = 5180

TURNING RADIUS (r) = 10500

- NOTES:
- (i) MINIMUM HEADROOM REQUIRED 4.37m
 - (ii) PROJECTION OF OUTRIGGERS FROM BODY LINE 0.61m
 - (iii) HEADROOM REQUIRED OR TO ELEVATE A TURNTABLE 10.06m
 - (iv) ALL DIMENSIONS IN MILLIMETRES

DIAGRAM 2.2.3.5 : CONTAINER TURNING CIRCLES

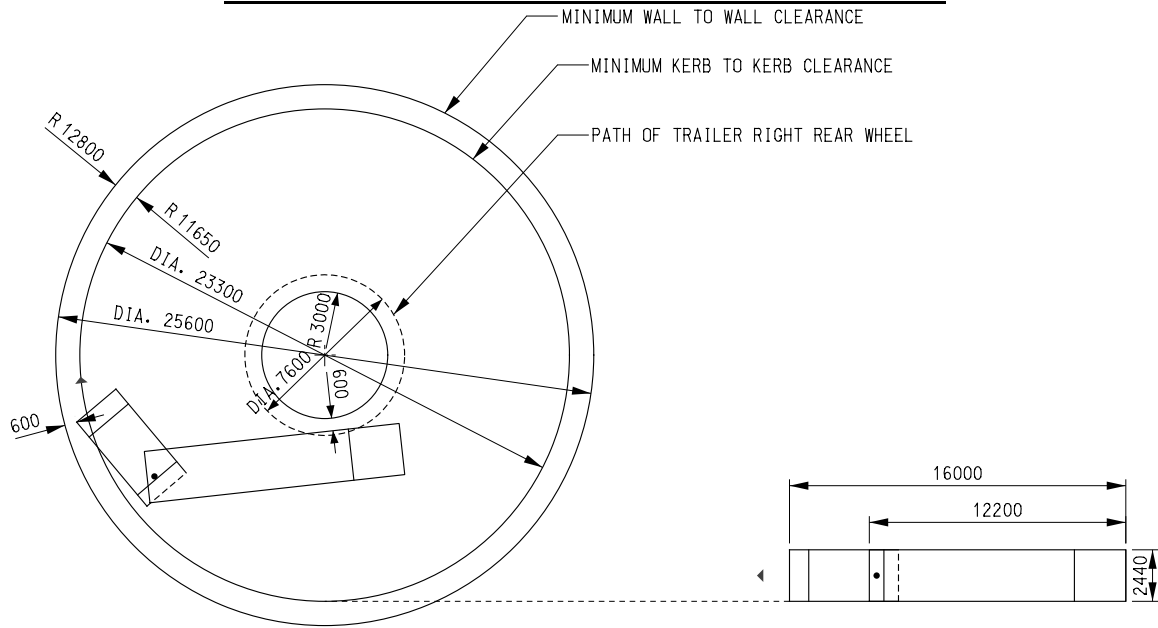

NOTE: ALL DIMENSIONS IN MILLIMETERS

DIAGRAM 2.2.3.6 : 90° & 180° TURNING CONTAINER
180° TURNING

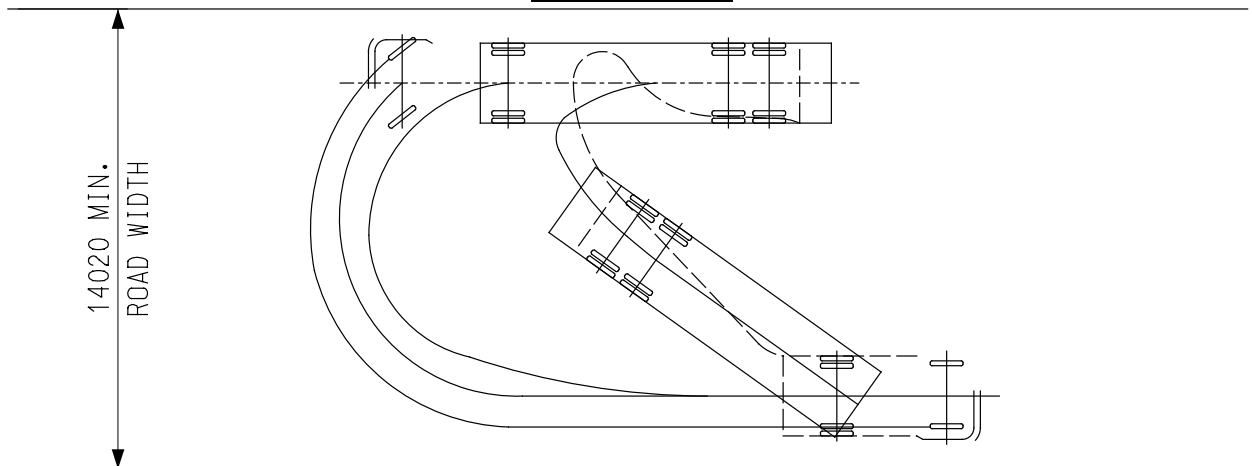

90° TURNING

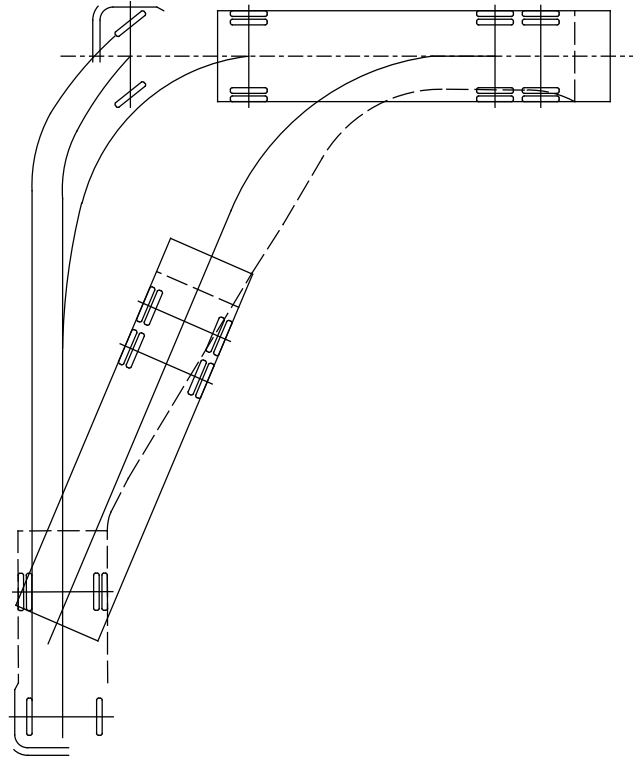

NOTE: ALL DIMENSIONS ARE IN METRES

DIAGRAM 2.2.3.7 : BUS TURNING CIRCLES
BUS DAIMLER FLEETLINE

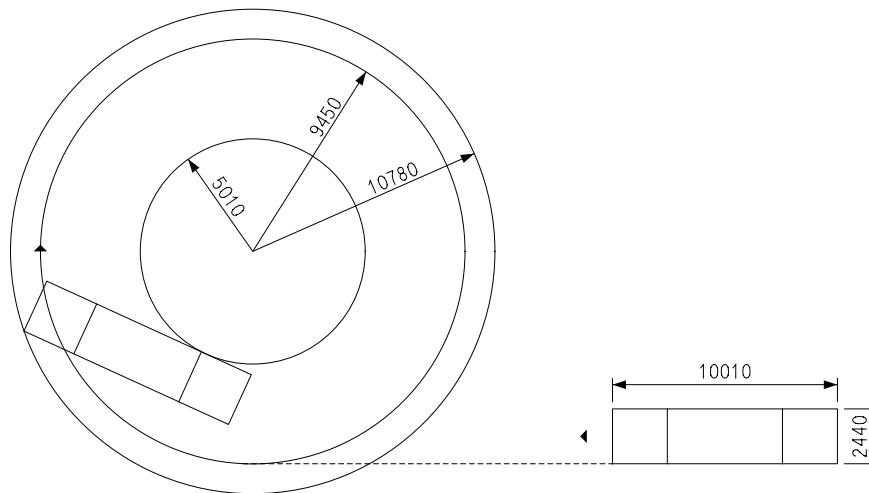

METRO BUS

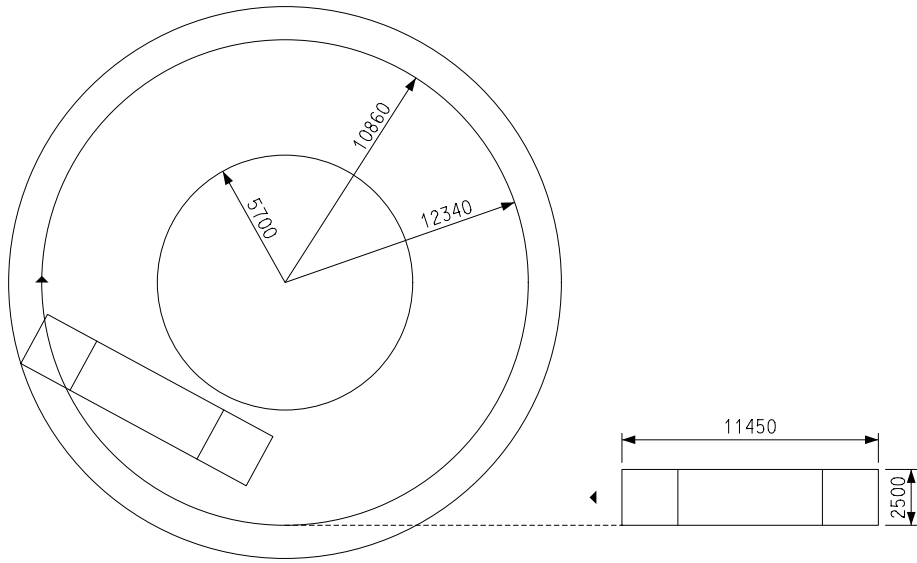

12m BUS

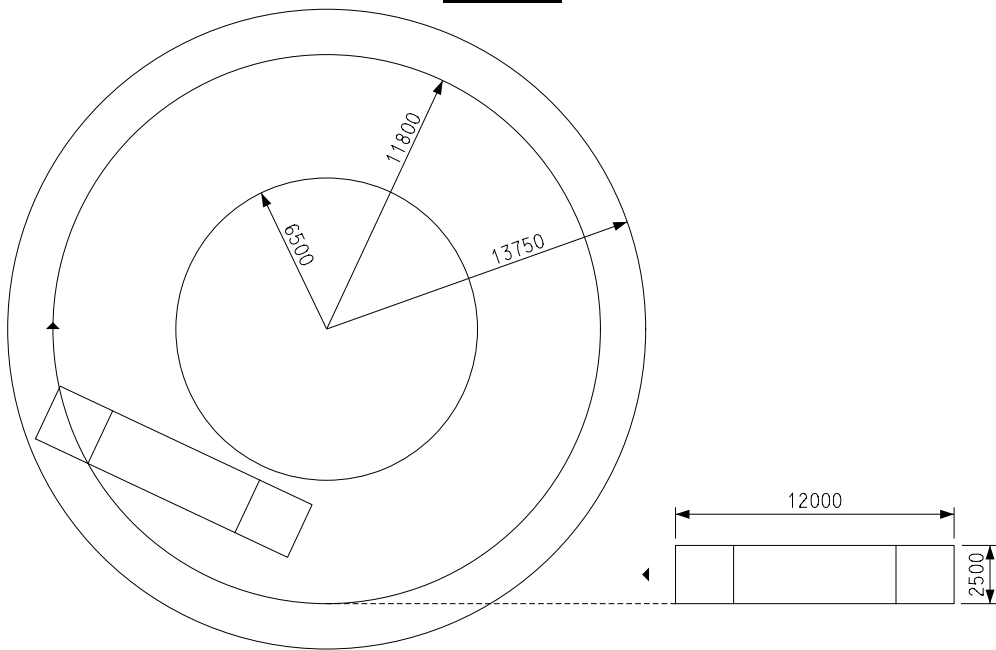

NOTE: ALL DIMENSIONS ARE IN METERS

DIAGRAM 2.2.3.8 : TURNING CIRCLES

TORUIST BUS

AUSTIN 950 FJ CHASIS

9.15 x 2.44

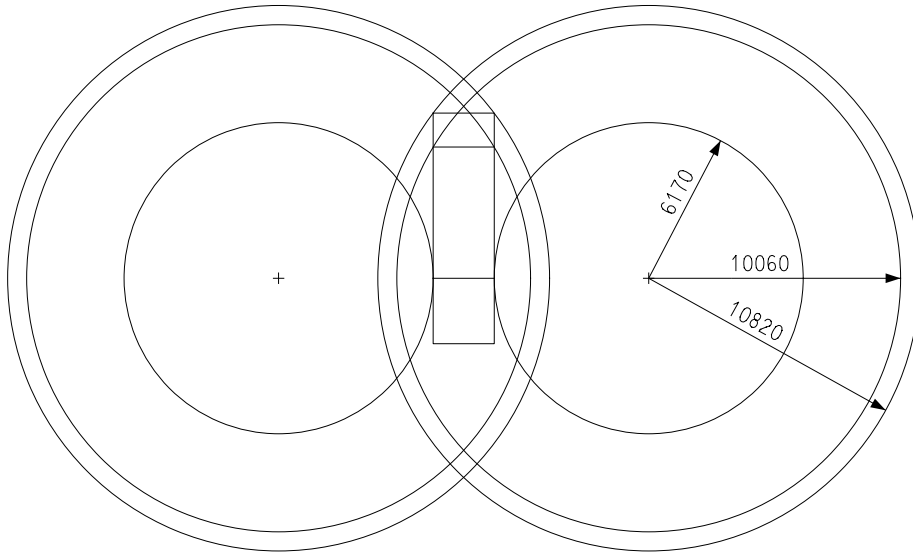

TOURIST BUS

35 SEATER BEDFORD

9.09 x 2.39

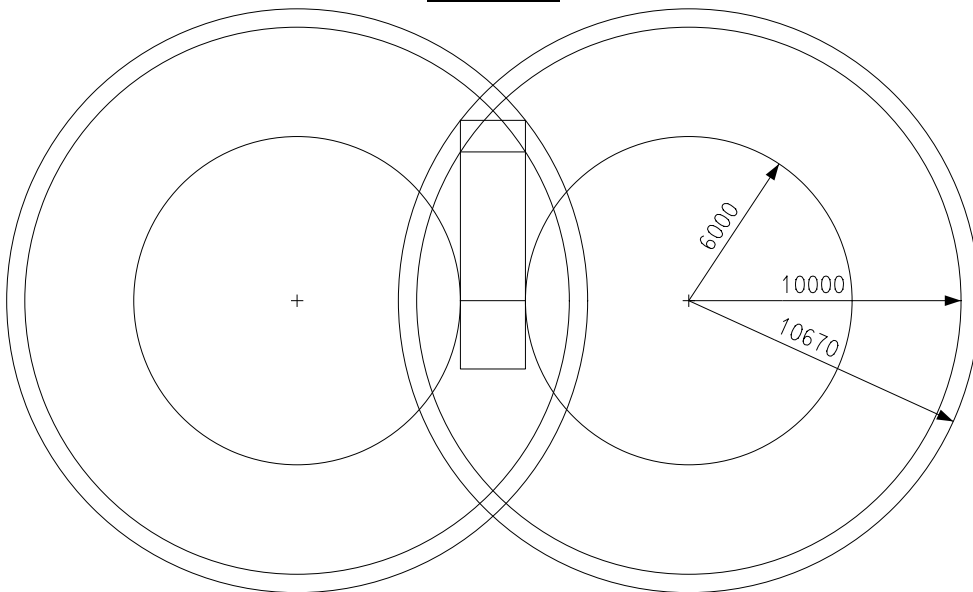

NOTE: ALL DIMENSIONS ARE IN METERS

DIAGRAM 2.2.3.9 : PREDICTION OF RIGID VEHICLE SWEEP PATH
- SCHNEIDER METHOD

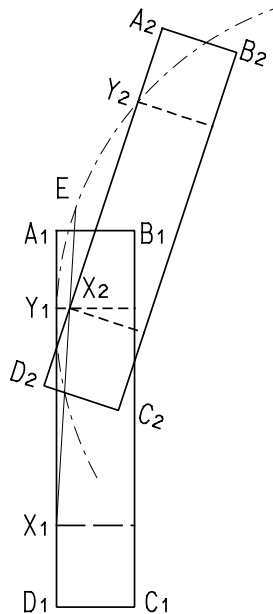
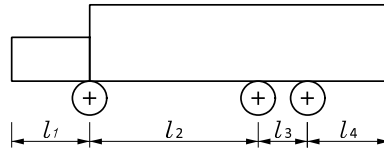

1. DRAW APPROPRIATE RADIUS R_1 , i.e. 10m, 12m, 15m.
2. DRAW OUTLINE OF VEHICLE WHERE $A_1 B_1$ & $D_1 C_1$ = WIDTH, $A_1 D_1$ AND $B_1 C_1 = l_1 + l_2 + l_3 + l_4$ AND Y_1 OUTSIDE POINT OF FRONT AXLE, COINCIDES WITH TANGENT POINT AND $A_1 Y_1 = l_1$, $Y_1 X_1 = l_2 + l_3$ AND $X_1 D_1 = l_4$.
3. DRAW ARC FROM POINT Y_1 OF RADIUS \neq THAN WHEEL BASE, i.e. $Y_1 X_1$ TO INTERSECT RADIUS R_1 AT Y_2 .
4. POINT E IS MID-POINT OF ARC $Y_2 Y_1$.
5. JOIN E X_1 .
6. DRAW ARC OF RADIUS $Y_1 X_1$ FROM POINT Y_2 .
7. WHERE ARC INTERSECTS E X_1 IS POINT X_2 , NEXT POSITION OF OUTSIDE REAR AXLE.
8. JOIN $X_2 Y_2$.
9. CONSTRUCT A_2, B_2, C_2, D_2 NEXT POSITION OF VEHICLE, i.e. $A_2 Y_2 = l_1$,
 $A_2 B_2 =$ WIDTH,
 $A_2 D_2 = l_1 + l_2 + l_3 + l_4$
10. REPEAT UNTIL VEHICLE COMPLETES TURN, eg. 90° or 180° .

DIAGRAM 2.2.3.10 : PREDICTION OF ARTICULATED VEHICLE SWEEP PATH
- SCHNEIDER METHOD

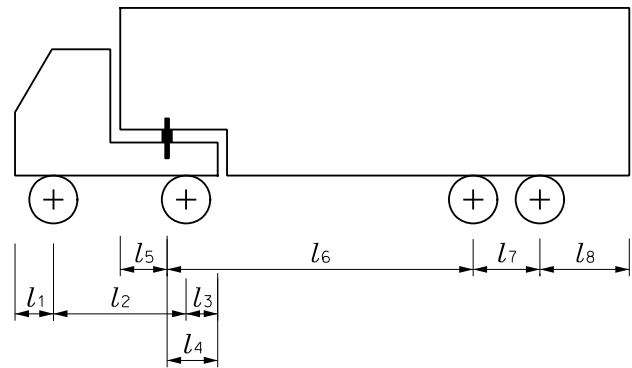
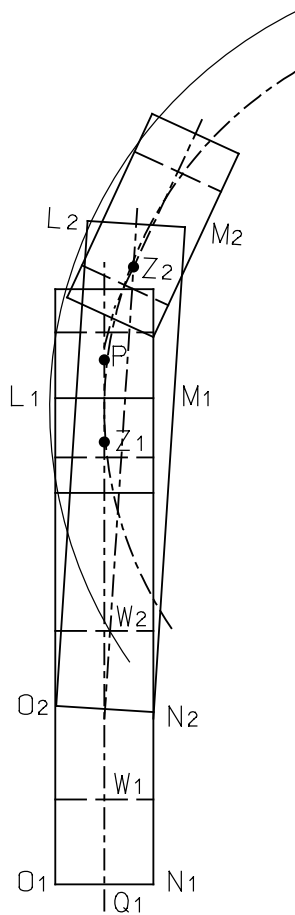

1. DRAW APPROPRIATE RADIUS, 10m, 15m, etc.
2. DRAW OUTLINE OF TRACTOR AND TRAILER UNITS. THE TRACTOR UNIT SHOULD BE PLOTTED AS FOR THE RIGID VEHICLE EXAMPLE. HOWEVER, WHEN PLOTTING THE NEXT POSITION OF THE TRACTOR THE ARC RADIUS $Y_1 Y_2$ MAY BE TAKEN AS BEING GREATER THAN THE WHEEL BASE. APPROXIMATELY $1.5 \times$ WHEEL BASE HAS BEEN FOUND TO BE CONVENIENT LENGTH.
3. DRAW RADIUS R_2 THROUGH PIVOT POINT Z_1 CONCENTRIC TO OUTSIDE RADIUS.
4. PLOT NEXT POSITION OF TRACTOR UNIT AND Z_2 NEXT POSITION OF PIVOT POINT, ALONG R_2 , WHERE $l_4 =$ DISTANCE OF PIVOT FROM REAR OF TRACTOR.
5. FIND P MID POINT OF ARC $Z_1 Z_2$.
6. DRAW LINE FROM W_1 TO P, WHERE $W_1 Q_1 = l_8$.
7. DRAW ARC OF RADIUS $l_6 + l_7$ FROM Z_2 .
8. WHERE ARC INTERSECTS $W_1 P$ IS NEXT POSITION W_2 OF CENTRE OF REAR AXLE.
9. JOIN $W_2 Z_2$ (C OF TRAILER) AND CONSTRUCT $L_2 M_2 N_2 O_2$.
WHERE $L_2 M_2 =$ WIDTH OF TRAILER
AND $M_2 N_2 = l_5 + l_6 + l_7 + l_8$.
10. REPEAT UNTIL COMPLETE TURN PLOTTED.

DIAGRAM 2.2.3.11 : TURNING CIRCLE
PUBLIC LIGHT BUS
6990 x 2080

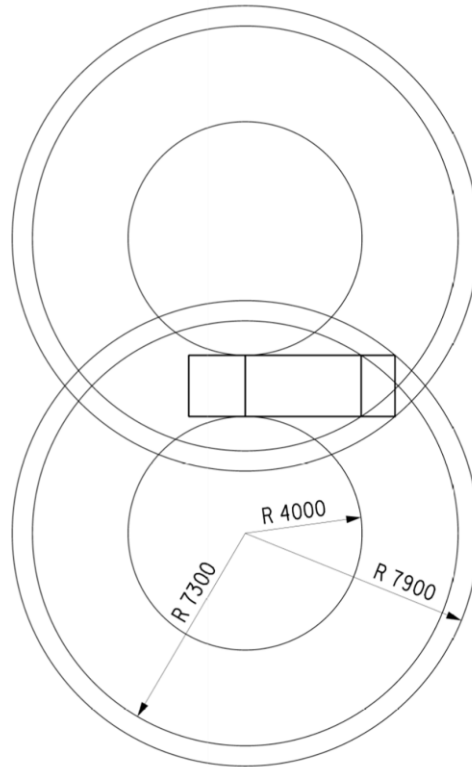

NOTE: ALL DIMENSIONS ARE IN MILLIMETERS

2.3 Passenger Car Units

2.3.1 Passenger Car Unit (pcu) Values

2.3.1.1 Passenger Car Unit values are given in Table 2.3.1.1.

Table 2.3.1.1
Passenger Car Units (pcu)

	Equivalent Value in pcu's					
	Urban Standard		Rural Standard		Roundabout	Traffic Signal Design
Private Car, Taxi	1.0		1.0		1.0	1.0
Light Goods Vehicle	1.5		1.5		1.5	1.5
Motor Cycle Motor Scooter	0.75		1.0		0.75	0.40
	Terrain					
	Ave	Hilly	Ave	Hilly		
Medium Goods Vehicle	2.0	3.0	2.0	3.0	2.8	1.75
Heavy Goods Vehicle	2.5	3.0	2.5	3.0	2.8	1.75
Bus	2.5	3.0	2.5	3.0	2.8	2.0
Pedal Cycle	0.35		0.5		0.5	0.2
Tram	3.0		-		-	3.5-5.0+
Light Bus	1.5		1.5		1.5	1.5
Special purpose bus	2.0		2.0			
Light Van	1.1		1.1		1.1	1.1
Tractor unit	2.5	3.0	2.5	3.0		

2.3.1.2 The pcu values for hilly terrain are appropriate where the gradient is greater than 4%, or there are long lengths of gradient approaching 4%.

2.3.1.3 The tram pcu values vary from 3.5 for a clear approach to a junction, to 5.0 where a tram island is sited near an approach. Where a tramway reserve is provided or where the frequency of tram movements is so high as preclude the use of its lane by other vehicles, that lane should be excluded in capacity calculations for mixed traffic.

2.4 Design Flow Characteristics

2.4.1 Design Flow

2.4.1.1 Design flow is the maximum volume of vehicles using the road without the traffic density becoming such as to cause unreasonable delay, hazard or restriction to the drivers freedom to manoeuvre. The operating condition of a road is normally assessed by comparing its peak hourly flow against its design hourly flow. It is not advisable to assess the operating condition of a road on the basis of its daily flow as the daily flow pattern of a road can vary significantly depending on the types of traffic (such as residential, industrial, or commercial developments) served by the road which affects significantly how well the capacity in the off-peak period can be utilized. Typical values are shown in Table 2.4.1.1

Table 2.4.1.1
Design Flows

Road Type	2 lane carriageway			Undivided carriageway		Dual carriageway			
	Peak hourly flow Veh/hour, both directions of flow+			Peak hourly flow Veh/hour, one direction of flow		Peak hourly flow Veh/hour, one direction of flow			
				4 lane		Dual 2 lane		Dual 3 lane	Dual 4 lane
	6.75m	7.3m	10.0m	13.5m	14.6m	Dual 6.75m	Dual 7.3m	Dual 11.0m	Dual 14.6m
Expressway/trunk road							3000	4700	6300
Primary distributor no frontage crossings, no standing vehicles, negligible cross traffic		2000	2400	2400	2600	2600	2800	4200	
District distributor frontage development, side roads, pedestrian crossings, bus stops, loading restrictions at peak hours	1400	1700	2200	1900	2000				

+Since the capacity of this type of road is significantly affected by the amount of kerb activities, pedestrian traffic and crossings, distance between side roads and junctions, etc., careful consideration on the actual site condition should be made before adopting these figures. For local roads, the design flow of a 2-lane single carriageway may be taken as 800 veh/h, 2-way, due to the presence of loading activities, standing vehicles and pedestrian crossings.

2.4.1.2 The design flows in Table 2.4.1.1 allow for a proportion of heavy vehicles equal to 15%. Heavy vehicles include all medium/heavy goods vehicles, non-franchised buses and franchised buses. No allowance will need to be made for lower proportions of heavy vehicles. The peak hourly flow at the year under consideration should be reduced in accordance with Table 2.4.1.2 when the expected proportion exceeds 15%. In some extreme cases (e.g. with very high component of heavy vehicles), converting the vehicles to pcu for analysis might be necessary.

Table 2.4.1.2
Reduction of Peak Hourly Flow for
Heavy Vehicles in Excess of 15%

Heavy vehicle content	Reduction in design flow level (%)	
	Expressway, trunk road and dual carriageway	Single carriageway
	per lane	per carriageway
15 - 20%	7	7
20 - 25%	10	10

- 2.4.1.3 Besides the proportion of heavy vehicles, it should be noted that the design capacity of a road would be affected by factors such as its horizontal/vertical alignment, design standards, existence of access, kerb side activities, etc.
- 2.4.1.4 The Design Year will be determined by the particular project under consideration. A design year between 15 and 20 years after the expected commissioning of the road is preferable, but planning data is generally unavailable for such a distant horizon. Currently the year 2016 is generally adopted since major strategic and regional transport planning studies are carried out with a planning horizon up to 2016. However, the Design Year chosen should be subject to the agreement of Transport Department.
- 2.4.1.5 Where predicted flows indicate a carriageway width in excess of 3 lanes is required for a dual carriageway road other considerations such as, the practicality of providing this, traffic operating conditions, and whether an alternative and/or an additional route should be provided, will also need to be taken into account.
- 2.4.2 Peak Hourly Flows/Design Flow Ratios P/Df**
- 2.4.2.1 Comparison of predicted flows to design flows may be useful in analyzing a network. Such comparisons should however always be related to hourly flows as daily flows can be extremely misleading due to the variability of peaking characteristics.
- 2.4.2.2 Table 2.4.2.1 indicates the implications of various Peak Hourly Flows/Design Flow ratios, (P/Df) for dual carriageways or single 4-lane carriageways with no frontage access and no standing vehicles. The table is not applicable to single 2-way 2-lane carriageways, as the operational characteristics of such roads are often dictated by road junctions, kerb-side activities, pedestrian crossings and opportunities to overtake.
- 2.4.2.3 With regard to existing roads, care should be exercised in interpreting P/Df ratios as many lengths of existing road are constrained by the capacity of existing junctions, and lack of stopping restrictions. Whilst from Table 2.4.2.1 a P/Df ratio of 0.7 might infer adequate operating conditions, the effect of junctions or traffic signals both within and at the end of the road link may be such that the design flow could never be achieved in practice, and the link might be severely congested well before a P/Df ratio of 1.0 is reached.

Table 2.4.2.1
Implications of P/Df Ratios

<u>P/Df Ratio</u>	<u>General Operational Characteristics</u>
Up to 0.3	Free-flow conditions Travel speeds at the free-flow speed generally prevail Ability to manoeuvre within traffic stream almost unimpeded Minor disruptions are easily absorbed without change in speed.
0.3 - 0.5	Easy flow conditions Travel speeds close to free-flow speed Ability to manoeuvre within traffic stream slightly restricted Minor disruptions are easily absorbed with localised reduction in speed.
0.5 - 0.75	Generally easy flow conditions. Travel speeds begin to be restricted by traffic conditions. Ability to manoeuvre within traffic stream is noticeably restricted. Minor disruptions may cause local congestion with short traffic queues.
0.75 - 1.0	Well used flow conditions. Travel speeds reduced by increasing traffic volumes. Ability to manoeuvre within traffic stream is severely restricted. Minor disruptions may cause local congestion with traffic queues.
1.0 - 1.2	Unstable flow conditions. Travel speeds substantially reduced and are highly variable & unpredictable. Little or no room to manoeuvre within traffic stream. Minor disruptions will cause substantial congestion with long traffic queues.
>1.2	Forced or breakdown flow conditions. Crawling travel speed. Highly unstable traffic operations with widespread congestion and extensively long traffic queues.

TPDM Volume 2 Chapter 3 – Road Characteristics

3.1 References

1. Departmental Standard TD 9/93 Road Layout and Geometry: Highway Link Design D.O.Tp. 1993.
2. Country Surveyors' Society Highway Transition Curve Tables (metric). The Carriers Pub. Co. Ltd. 1965.
3. T.T.S.D. Data Record 182. Pedestrian Movement in the Central District of Hong Kong 1974.
4. D.O.E. Technical Memorandum H2/70 - Pedestrian Subways, Layout and Dimensions.
5. United Nations - Recommended Practice for the Design and Layout of Cycle Tracks, Feb. 1973.
6. Highways Office - Guide Lines for the design of Cycle Facilities - New Territories, Highways Office of Public Works Department, 1976.
7. Traffic Engineering Division - A Policy on Run-ins, July 1970.
8. Report of the Working Party on Transport for the Disabled, March 1975.
9. Design Manual: Barrier Free Access, 1997. Buildings Department, 1997.
10. Highway Capacity Manual 1965, Highway Research Board, Special Report 87.
11. Departmental Standard TD 31/93. Subway for Pedestrians and Pedal Cyclists Layout and Dimensions, D.O.Tp.16.B.S. 5395: 1977. Code of Practice for Stairs.
12. Road Traffic (Traffic Control) Regulation 1984.
13. Hong Kong Long Term Road Study - Freeman Fox Wilbur Smith Associates, 1968.
14. Third Comprehensive Transport Study - Wilbur Smith Associates Limited, October 1999.
15. Comprehensive Traffic Surveillance and Control Study - Maunsell Consultants Asia 1980.
16. P.I.A.R.C. Road Tunnel Technical Committee Report of Working Group IV. Geometry 1975.
17. Departmental Advice Note TD 42/95. Junctions and Accesses: Geometric design of Major/Minor Priority Junctions. U.K. Department of Transport
18. The Research and Development Background to "Highway Link Design" D. Simpson and J.A. Kerman. Traffic Engineering and Control, Sept. 1982.
19. Departmental Advice Note TA 66/95. Police Observation Platforms on Motorways. The Highways Agency.
20. The Overall Effect on Accidents at Sites Where Zebra Crossings were Installed. J.R. Landles. Traffic Engineering Control January 1983.
21. Data Record No. 361. Warrants for Escalators at Footbridges.
22. Providing For The Cyclist. Institution of Highways and Transportation July 1983.
23. Structures Design Manual for Highways and Railways, 1997.

24. Roads and Traffic in Urban Areas. The Institution of Highways and Transportation with the Department of Transport. 1987.
25. Pedestrianisation Guidelines. The Institution of Highways and Transportation. 1989.
26. Design Manual for Roads and Bridges, Volume 6 Road Geometry. The Department of Transport, June 1993.
27. Public Lighting Design Manual, Highways Department
28. Highways Department Standard Drawings, Highways Department
29. The Standard Drawings of Structures Division of Highways Department
30. Departmental Standard TD 36/93, Subways for Pedestrians and Pedal Cyclists Layout and Dimensions, D.O.Tp.
31. Roads and Traffic in Urban Areas, Institution of Highways and Transportation with the Department of Transport, 1987
32. National Cooperative Highway Research Program (NCHRP) Report 350, Transport Research Board, National Research Council, U.S.A.
33. Road Research Laboratory Report LR 104, Ministry of Transport, 1967
34. Road Design Guide, Section 6 - Safety Barriers for Roads and Bridges, Roads and Traffic Authority, May 1996
35. Roadside Design Guide, American Association of State Highway and Transportation Officials, 1989.

3.2 Road Types

3.2.1 Rural Road Types

3.2.1.1 Trunk Roads - Roads connecting the main centres of population. High capacity roads with no frontage access or development, pedestrians segregated, widely spaced grade-separated junctions, and 24 hour stopping restrictions.

3.2.1.2 Rural Roads - Roads connecting the smaller centres of population or popular recreation areas with major road networks. Frontage access should be limited wherever possible and junction design whilst not necessarily grade separated should be of a high capacity standard.

3.2.1.3 Feeder Roads - Roads connecting villages or more remote settlements to Rural Roads.

3.2.2 Urban Road Types

3.2.2.1 Trunk Roads - Roads connecting the main centres of population. High capacity roads, with no frontage access or development, segregation of pedestrians, widely spaced grade-separated junctions, and 24 hour stopping restrictions.

3.2.2.2 Primary Distributor - Roads forming the major network of the urban area. Roads having high capacity junctions, though may be at-grade, segregated pedestrian facilities wherever possible and frontage access limited if not entirely restricted, and 24 hour stopping restrictions.

3.2.2.3 District Distributors - Roads Linking Districts to the Primary Distributor Roads. High capacity at-grade junctions, with peak hour stopping restrictions and parking restrictions throughout the day.

3.2.2.4 Local Distributors - Roads within Districts linking developments to the District Distributor Roads.

3.2.3 Expressway

3.2.3.1 Roads are designated as Expressways under the Road Traffic (Expressway) Regulations. An expressway may be formed from a trunk road or a primary distributor road. Details of Expressway standards are contained in Chapter 6 of this Volume.

3.3 Road Alignment

3.3.1 General Principles

3.3.1.1 When designing a new road or improving an existing road, the alignment should be selected with care so as to :

- (i) Minimise any detrimental effects that may be caused by noise or fumes on the surrounding environment.
- (ii) Ensure that communities are not unnecessarily severed or cross movements unduly restricted.

3.3.1.2 On dual carriageway roads, the alignment should aim to provide at least the minimum standards defined in the following Sections. In addition, the following principles should be followed wherever practicable to secure a satisfactory alignment.

- (i) Horizontal and vertical curves should be as large as possible.
- (ii) Changes in horizontal and vertical alignment should be phased to coincide particularly on high speed roads. Where this is not possible, one curve, usually the horizontal curve, should embrace the other.

3.3.1.3 Rural locations and urban locations are those areas where the Road Types referred to in Section 3.2 occur. Generally therefore, Hong Kong Island, Kowloon and new towns will have urban locations, and the New Territories outside of new towns will have rural locations.

3.3.1.4 Whilst the Design Speed derived minimum geometry as detailed in the following Sections is equally relevant to single carriageway design, the additional dimension of opposing vehicles means that the various geometric parameters must, for rural roads, be assembled with much greater care than the simple aesthetic design considerations described in paragraph 3.3.1.2, that is :

- (i) For the improvement of existing rural single carriageways, evidence of operational problems always exist. Sharp bends and junctions causing congestion or accidents can be identified for improvement; hill sections causing congestion can be identified for the provision of passing bays or climbing lanes. Proposals for improvement should concentrate on those features with evident problems, and not on bringing the entire alignment up to standard .
- (ii) The design of significant lengths of new rural single carriageway roads, however, (in excess of 3-4 km), creates a real problem for the designer to ensure that the design will appear to the driver to be a conventional single carriageway, and not a high speed route. The alignment recommendations for dual carriageways shown in 3.3.1.2, are not appropriate for single carriageways. Great care should be taken in selecting the alignment, and mid to large radius curves should be avoided in favour of straight, with short, low radius curves to facilitate changes of horizontal and vertical alignment. Such curves shall be accompanied by conventional double white line road markings and signs to prevent overtaking at these points. Climbing lanes should be provided on gradients to ensure regular opportunities for passing slow moving vehicles.
- (iii) In urban locations, the frequency of junctions, traffic signals, etc., and low operating speeds means that no special consideration need be paid to design, beyond normal Design Speed geometric requirements.

3.3.1.5 There is clearly a dilemma where a single carriageway is considered as the first stage of an eventual dual carriageway scheme, in that the alignment for the first stage single carriageway would be incompatible with the eventual dual carriageway design. Such staged construction arrangement is considered undesirable from road safety point of view. If a staged construction is absolutely necessary, the road alignment at the first stage should be properly designed and constructed. Furthermore, sufficient land should be allowed for expansion to accommodate the capacity required for any future widening of the road.

3.3.2 Design Speed

3.3.2.1 The Design Speed of a road is the speed chosen to correlate the various features of design, such as the minimum horizontal and vertical curvature, superelevation, transitions, junction visibility, signs and road markings etc. It should be chosen to be a realistic estimate of the likely vehicle speeds that will occur, and should represent the 85%-ile speed of light vehicles in free flow conditions.

3.3.2.2 The speed of vehicles is mainly dependant upon the type of road, whether single or dual carriageway, the degree of access control, and the type of junctions provided. Low order geometry has been shown to have little effect on vehicle speeds, and a few difficult locations where topographical or development constraints necessitate low radius curves will not significantly reduce operating speeds. Where, however, a route is continually constrained to frequent low radius curves to avoid topographical or development features, speeds will be somewhat lower due to the sinuous nature of the route.

3.3.2.3 A 50-80-100 km/h three tier speed limit structure is to be adopted for all new roads. The design speeds for different road types are recommended in Table 3.3.2.1.

Table 3.3.2.1
Design Speeds

<u>Road Type</u>	<u>Type of Junction and Access</u>	<u>Design Speed(km/h)</u>
Rural Dual Carriageway	i) Expressway Standards, No Frontage Access and Widely Spaced Grade Separated Junctions	100
	ii) No Frontage Access and Closely Spaced Grade Separated Junctions	80
	iii) Some Frontage Access and At Grade Junctions	50
Urban Dual Carriageway	i) No Frontage Access, Frequent Elevated Structures and Grade Separated Junctions	80
	ii) Some Frontage Access and Signal Control Junctions	50
Rural Single Carriageway	i) Some Frontage Access and At Grade Junctions	50
Urban Single Carriageway	i) Some Frontage Access and At Grade Junctions	50
	ii) Local Streets	50

3.3.3 Horizontal Curvature

3.3.3.1 Minimum Radii

Table 3.3.3.1 shows the appropriate radii and superelevation for various Design Speeds. Wherever possible, radius of R3 or greater should be used. Radii less than R3 should only be used at isolated locations, where excessive cost would result from the use of R3. For new roads with a design speed of 80 km/h or above, a desirable minimum radius of R4 should be adopted. (Radii should be related to the inside curve of the carriageway).

Table 3.3.3.1
Appropriate Radii and Superelevation

<u>Design Speed</u> (km/h)	<u>Normal Minimum Radius</u>						<u>Absolute Minimum Radius</u>	
	R8 (m)	R7 (m)	R6 (m)	R5 (m)	R4 (m)	R3 (m)	R2 (m)	R1 (m)
120	2800	2000	1400	1000	700	500	350	250
100	2000	1400	1000	700	500	350	250	175
85	1400	1000	700	500	350	250	175	125
80	1280	900	650	450	320	230	160	115
70	1000	700	500	350	250	175	125	88
60	700	500	350	250	175	125	88	63
50	500	350	250	175	125	88	63	44
Superelevation	2.5%	2.5%	3.5%	5%	7%	10%	10%	10%

3.3.3.2 Elimination of Adverse Camber

Adverse camber should be replaced with favourable crossfall of 2.5% when radii greater than R7 are used.

3.3.3.3 Superelevation

For radii between R7 and R3, superelevation should be provided such that:

$$S = \frac{V^2}{2.82R}$$

where: S = Superelevation (%)

V = Design Speed (km/h)

R = Radius (m)

For Radii below R3, however, which should only be used at difficult locations, a maximum superelevation of 10% should be maintained, together with suitable road surfacing to ensure adequate skid resistance. However, 10% superelevation should be avoided if there is a possibility of stationary or slow moving heavy goods vehicles. For new roads with a design speed of 80 km/h or above, a desirable maximum superelevation of 7% in conjunction with a desirable minimum radius of R4 should be adopted, together with a suitable road surfacing to ensure adequate skid resistance.

3.3.3.4 Superelevation on Urban Roads

Roads in built up areas with at-grade junctions and accesses should not be superelevated too steeply, and should preferably not exceed 4-5%. Where the use of radius between R5 and R1 is made necessary by severe constraints on the alignment, superelevation should be limited to 5% together with suitable road surfacing to ensure adequate skid resistance.

3.3.4 Transitional Design

3.3.4.1 Superelevation should not be introduced, nor adverse camber removed, so gradually as to create large almost flat areas of carriageway, nor so sharply as to cause discomfort or to kink the edge of the carriageway. Generally, the carriageway edge profiles should not vary in grade by more than 1%, and to ensure satisfactory drainage, a minimum longitudinal gradient of 0.67% should be maintained through the transitional area. However, in some difficult areas, even the above requirements can cause drainage problems, and it may be necessary to increase the variation in grade of the edge profile, or apply a rolling crown in a similar manner to that required for a level or near level road.

3.3.4.2 In general, the transition curve to be used is clothoid, as described in the *Highway Transition curve tables (metric)* compiled by the County Surveyors Society (1963). Under normal design conditions, it should be possible to apply the superelevation within the transition length, and satisfy the dual criteria that :

- (i) The superelevation should be applied so that the difference in grade of the two edge profiles does not exceed 1%; and
- (ii) The maximum rate of change of centripetal acceleration does not exceed 0.3m/sec^3 .

However, it will frequently be impractical to achieve such long transitional designs in the dense constraints of Hong Kong, as these criteria tend to force contiguous curves apart, and severely restrict the ability of the road to conform to alignment constraints.

3.3.4.3 On elevated structures where the use of clothoid transitions may create difficulties with complex geometry it may be suitable to adopt a circular curve in place of the clothoid transition provided it can be clearly demonstrated that there would be no significant difference in alignment.

3.3.4.4 The basic transition length shall be derived from the following formula:

$$L = \frac{V^3}{46.7qR}$$

where: L = Length of transition (m)

V = Design Speed (km/h)

q = Rate of increase of centripetal acceleration (m/sec^3) travelling along curve at constant speed V

R = Radius of curve (m)

3.3.4.5 Table 3.3.4.1 illustrates the transition length requirements for the various curve radii, together with the appropriate shift. Transition lengths of $1.4V$ (where V = design speed km/h) or higher will often place severe limitations in areas of difficulty, and it will be necessary to increase the rate of change of centripetal acceleration to 0.6 or even higher where low radius curves occur in close proximity. At the same time, especially on multi-lane highways, it will often not be possible to introduce the superelevation as gradually as 1% within the transition, and it may be necessary to increase the variation in edge profile to 1% or even 2%.

3.3.4.6 For ease of design and setting out, the County Surveyors Society Tables provide a range of transitional spirals and it will be appropriate to adopt the spiral with the nearest RL value to that required by Table 3.3.4.1.

Table 3.3.4.1
Transition Lengths

<u>Radius</u>	<u>Rate of Change of Centripetal Acceleration</u> (with Shift in Bracket)			
	<u>0.3m/sec³</u>	<u>0.43m/sec³</u>	<u>0.6m/sec³</u>	<u>0.86m/sec³</u>
R6	0.7V(0.2m)			
R5	1V(0.6m)	0.7V(0.3m)		
R4	1.4V(1.7m)	1V(0.85m)	0.7V(0.4m)	
R3	2V(4.7m)	1.4V(2.4m)	1V(1.2m)	0.7V(0.6m)
R2	2.8V(13.3m)	2V(6.7m)	1.4V(3.4m)	1V(1.7m)
R1	4V(37.8m)	2.8V(18.8m)	2V(9.4m)	1.4V(4.7m)
<u>Design Speed</u> (km/h)	<u>RL Values</u>			
120	123000	86000	62000	43000
100	71000	50000	36000	25000
85	44000	31000	22000	15000
80	37000	26000	18000	13000
70	25000	17000	12500	8500
60	15000	11000	7500	5500
50	9000	6250	4500	3125

3.3.4.7 For radii greater than R7, the normal transition designed for 0.3m/sec³ will be insignificant and not generally required. However, where crossfall is being reversed from the adjacent curve, it may be suitable to provide a transition to apply the superelevation change. In such circumstances, longer transitions than normal will often be required to suit the superelevation design.

3.3.4.8 Progressive superelevation or removal of adverse camber should be achieved over or within the length of the transition curve from the curve end. Where a transition curve is not provided, approximately two thirds of the superelevation should be introduced on the approach, and the remainder at the beginning of the curve.

3.3.5 Sight Distance

3.3.5.1 Table 3.3.5.1 shows the sight distances that must be provided on the approaches to and through junctions, accesses, weaving sections and points of vehicular and pedestrian conflict, and the aim should be to provide the desirable minimum distance, rather than the absolute minimum distance.

Table 3.3.5.1
Sight distances

<u>Design speed</u> (km/h)	<u>Desirable minimum</u> (m)	<u>Absolute minimum</u> (m)
120	295	215
100	215	160
85	160	120
80	145	110
70	120	90
60	90	70
50	70	50

3.3.5.2 The sight distances should be measured from a minimum drivers' eye height of between 1.05 m and 2.0 m to an object height of between 0.26 m and 2.0 m , both above the road surface. Forward visibility should be provided in both the horizontal and vertical planes between points in the centre of the lane nearest to the inside of the curve.

3.3.5.3 Because of the necessity of providing sight distances in accordance with Table 3.3.5.1 and paragraph 3.3.5.1 it follows that junctions and accesses should not be located on sharp curves, as this would result in extensive widening of verges, cuttings and bridge structures in order to obtain the required visibility

3.3.5.4 For locations, not mentioned in paragraph 3.3.5.1, that are away from the vicinity of a junction or access or weaving section or place of vehicular or pedestrian conflict and where on the inside of a curve an obstruction, such as cutting slope, retaining wall, noise barrier, or bridge abutment, occurs, appropriate sight distances obtained in accordance with the following, must be provided:

(i) Low speed urban roads

Because there is little or no restriction on pedestrians and accesses along these roads the sight distances in accordance with Table 3.3.5.1, measured in accordance with paragraph 3.3.5.2 should be provided.

(ii) Roads having design speeds of 80 km/h or greater and the radius of the bend is less than R3

(a) For a 100 km/h design speed or greater a 4 m width must be maintained clear of obstructions on the inside of the curve, the clearance being measured from the edge of the running carriageway and may include any hard shoulder, marginal strip or verge.

(b) For 80 km/h design speed, a 3 m width clear of obstructions must be maintained, the width being measured as in (ii)(a) above.

(iii) Roads having design speeds of 80 km/h or greater, and the radius of the bend is R3 or greater

(a) For a 100 km/h design speed or greater, a 4 m width in accordance with (ii)(a) above, or a width determined from Table 3.3.5.1 measured in accordance with paragraph 3.3.5.2, whichever is the lesser, must be maintained free of obstructions.

(b) For 80 km/h design speed, a 3 m width in accordance with (ii)(b) above, or a width determined from Table 3.3.5.1 measured in accordance with paragraph 3.3.5.2, whichever is the lesser, must be maintained free of obstructions.

(iv) Roads having design speed of 50 km/h

This design speed in accordance with Table 3.3.2.1 is only appropriate for single carriageway roads and therefore sight distances in accordance with Table 3.3.5.1 must be provided.

3.3.5.5 Large direction signs, gantry supports or other substantial obstructions should be sited such that they do not obscure sight lines, although isolated slim objects such as lamp columns, or sign posts can be ignored. Laybys should wherever possible be sited on straight or the outside of curves where stopped vehicles will not obstruct sightlines.

3.3.5.6 For information on, visibility splays required at priority junctions, visibility requirements at roundabouts, and visibility requirements at grade separated interchanges, Sections 4.3.8, 4.5.11, and 4.6.6, respectively, of Chapter 4 in this Volume should be consulted.

3.3.6 Gradients

3.3.6.1 Whilst it is appreciated that topographical difficulties can influence considerably the economics of a road scheme, gradients should on Trunk Roads, and Primary Distributors conform with those given in Table 3.3.6.1.

Table 3.3.6.1
Maximum Gradients

<u>Type of Route</u>	<u>Gradient</u>	
	<u>Desirable Maximum %</u>	<u>Absolute Maximum %</u>
1. Trunk Roads, Primary Distributors and Bus Routes	4	8
2. Others	5	10

3.3.6.2 For new roads with a design speed of 80 km/h or above, a desirable maximum gradient of 4% should be adopted.

3.3.6.3 For effective drainage with kerbed roads, a minimum gradient of 0.67% should be maintained wherever possible. In flatter areas, however, the vertical alignment should not be manipulated by the introduction of repeated reverses of vertical curvature simply to achieve adequate surface water drainage gradients but alternative forms of edge drainage for a level or near level road should be devised. For lower speed urban roads, drainage paths may be provided by false channel profiles with minimum gradients of 0.67%, although for high speed roads, other forms of continuous drainage may be necessary.

3.3.7 Vertical Curves

3.3.7.1 Vertical curves should be provided at all changes of gradient, and should be at least as long as that indicated by the formula.

$$L = KA$$

where L = curve length in metres

A = algebraic difference in gradients (%)

K has a value selected from Tables 3.3.7.1 and 3.3.7.2.

Table 3.3.7.1
Minimum K Values for Vertical Crest Curves

<u>Design Speed</u> (km/h)	<u>Desirable Minimum</u> (K)	<u>Absolute Minimum</u> (K)
120	182	100
100	100	55
85	55	30
80	55	30
70	30	17
60	17	10
50	10	6.5

3.3.7.2 Visibility is the main factor that affects the Desirable Minimum crest curvature whereas comfort criteria apply for sag curves. Crest K-values should not be reduced below the Desirable Minimum values shown in Table 3.3.7.1 :

- (i) Where junctions or accesses are sited on or near crest curves such that approach visibility is restricted.
- (ii) On lower speed roads, where there are little or no restrictions on pedestrians and accesses.

3.3.7.3 Where K values of over 40 are used, the channel gradients will be flatter than 0.4% for more than 30m, and surface water drainage may require special attention.

Table 3.3.7.2
Minimum K Values for Vertical Sag Curves

<u>Design Speed</u> (km/h)	<u>Desirable Minimum</u> (K)	<u>Absolute Minimum</u> (K)
120	37	37
100	37	26
85	26	20
80	26	20
70	20	20
60	20	13
50	13	9

3.3.8 Climbing lanes for Single Carriageway Roads

- 3.3.8.1 Gradients can cause severe congestion on single carriageways, where a slow moving goods vehicle will create long platoons of traffic if faster vehicles are unable to overtake. These platoons will frequently be unable to dissipate for a considerable distance, as overtaking is a difficult and hazardous manoeuvre on a 2 lane road.
- 3.3.8.2 When improving an existing single carriageway road, such congested locations will be readily identified. Significant improvements in flow will be effected by the strategic provision of climbing lanes at frequent intervals on gradients to permit overtaking where it is most necessary. It is not suitable to provide gradient/traffic criteria for the provision of climbing lanes on single carriageways. Each site must be considered individually in relation to overtaking possibilities on the route as a whole, to arrive at the most suitable means of achieving improvements to traffic flow. In some cases, the provision of a climbing lane on a 2-3% gradient may represent the most advantageous means of ensuring that steady progress can be made.
- As an interim measure, the construction of strategically located passing bays should be considered where it is likely that a full climbing lane could not be achieved for some period of time, and the length of the road in question is greater than 500m.
- 3.3.8.3 For new single carriageway rural roads the provision of climbing lanes on hills offers the most economic and effective means of ensuring that there are frequent opportunities for overtaking and the strategic placing of climbing lanes will ensure steady progress. As with existing single carriageway roads, it is not possible to provide gradient/traffic criteria and each site must be considered on its merits in relation to overtaking opportunities on the route as a whole.
- 3.3.8.4 The minimum carriageway width at climbing lanes should be 10m, divided into 3 lanes. The climbing lane should be 3.2m wide, the other two being 3.4m each. Appropriate double white line road markings should be in accordance with Volume 3
- 3.3.8.5 Generally, the full width of the climbing lane should be provided at a point "S", 100m uphill from the point where the sag curve attains a 2% gradient, as shown in Diagram 3.3.8.1. A taper of 1 in 30 to 1 in 40 should be provided over the 100m length as in Diagram 3.3.8.2
- 3.3.8.6 The physical width of the climbing lane should generally be maintained to a point "F", 200m beyond the point where the crest curve reduces to 2% gradient, followed by a 100m taper. Cross hatching road markings and advance warning signs should be provided in advance of the taper, to channelise vehicles.(see Diagram 3.3.8.3).
- 3.3.8.7 At short hills, it may be necessary to commence the climbing lane in advance of point S so as to provide a minimum length of at least 200m of full width climbing lane. For existing roads, where crest curves may be substantially sharper than the minimum prescribed, it may be necessary to adopt a shorter terminal detail so as to prevent the lane reduction extending too far beyond the crest.

DIAGRAM 3.3.8.1 : CALCULATION OF GRADIENT FOR CLIMBING LANE PURPOSES

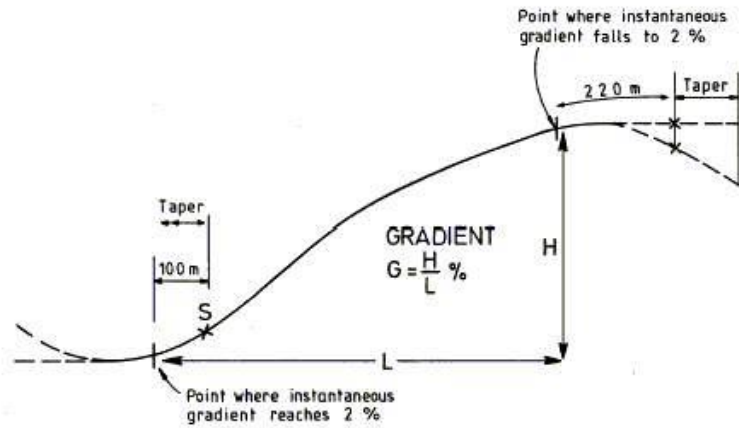

DIAGRAM 3.3.8.2 : START OF CLIMBING LANE

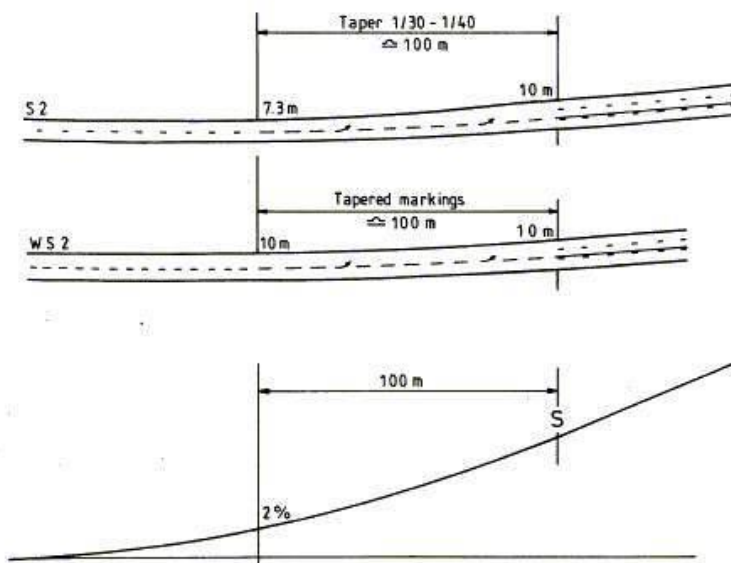
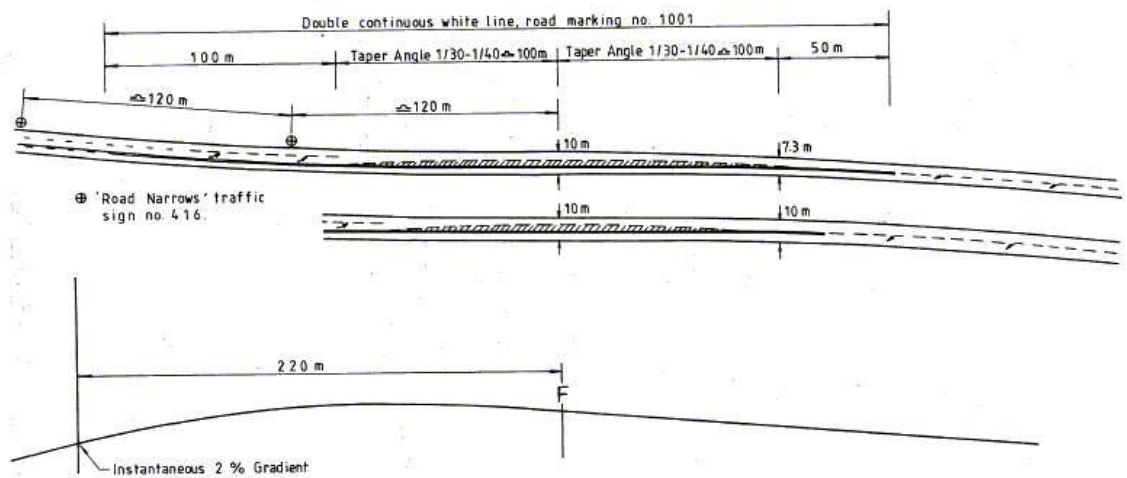

DIAGRAM 3.3.8.3 : END OF CLIMBING LANE



3.3.8.8 At crests, where climbing lanes are provided both sides of the hill and there is less than 500m between the ends of the tapers, the climbing lanes should be extended to overlap each other, providing a four lane carriageway at least 50m long. Continuous double white lines, if not used to separate the opposing lanes on either side of the hill, must be provided across the crest and extend at least 50m beyond the completion/start of the tapers in either direction, as in Diagram 3.3.8.4.

3.3.8.9 Where the climbing lane exceeds 3 km in length it is advisable to provide some sections with a straight or large radius right hand curvature as an overtaking section of downhill traffic.

DIAGRAM 3.3.8.4 : CREST CURVE BETWEEN 2 CLIMBING LANES

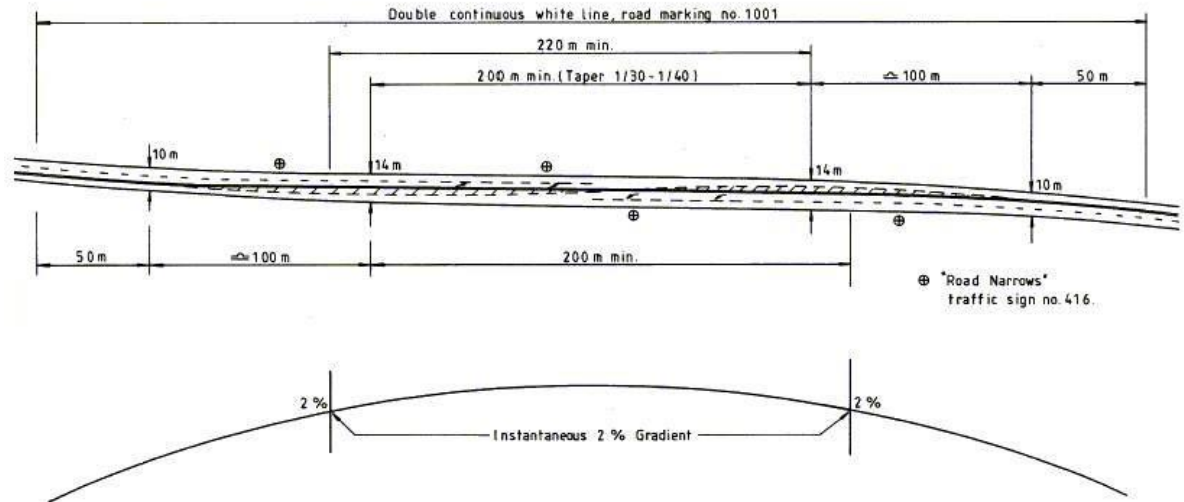

3.3.9 Climbing Lanes for Dual Carriageway Roads

3.3.9.1 An additional uphill lane should be provided on 2 lane dual carriageway roads if the forecast design year traffic flow exceeds the flow level indicated in Diagram 3.3.9.1 relative to the gradient of the hill. The Gradient $G = 100 H/L$ should be calculated in accordance with Diagram 3.3.9.1. An additional lane should be considered if the minimum gradient is 3% over a distance of 0.5 km.

3.3.9.2 Where costs of providing the additional land for a climbing lane are high relative to the total cost of the works, consideration should be given to adjusting the alignment of the carriageway within the standard highway width and reducing or eliminating the verge/marginal strip widths so that a climbing lane can be provided without any additional land being required, as shown in Diagram 3.3.9.2.

3.3.9.3 The appropriate full width of the climbing lane should be provided in similar manner to that for single carriageway, i.e. at a point "S", 100m from the 2% point of the sag curve. However a taper of at least 1 in 45 should be provided in the case of climbing lanes for dual carriageways, as shown in Diagram 3.3.9.3.

3.3.9.4 At the end of the climbing lane section the extreme left hand lane should be continued, and any tapering down should affect the extreme right hand lane as shown in Diagram 3.3.9.4.

3.3.9.5 Passing bays are not appropriate for dual carriageway roads.

DIAGRAM 3.3.9.1 : DUAL CARRIAGEWAY CLIMBING LANES JUSTIFICATION

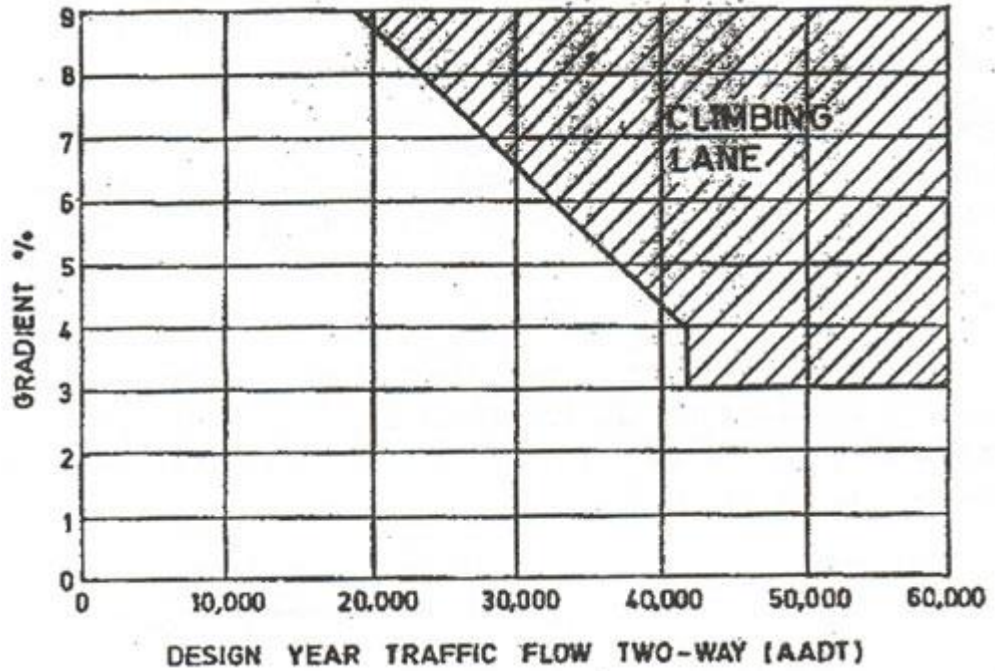
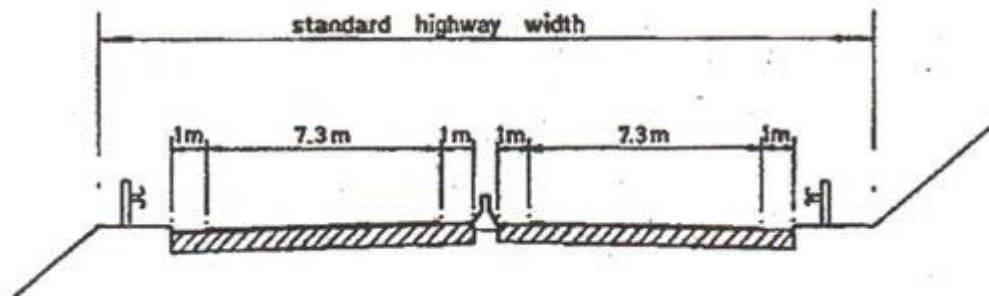

DIAGRAM 3.3.9.2 : CLIMBING LANE PROVISION WITHIN STANDARD HIGHWAY WIDTH

(a) WITHOUT CLIMBING LANE



(b) WITH CLIMBING LANE

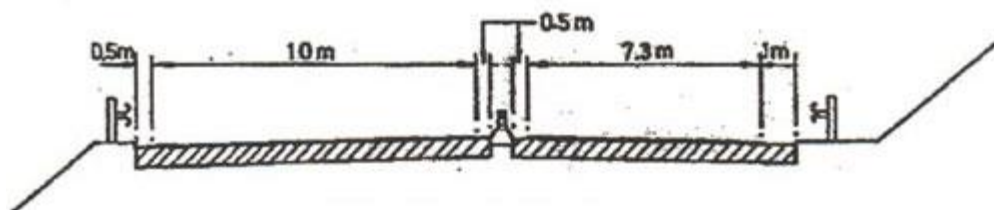

DIAGRAM 3.3.9.3 : START OF DUAL CARRIAGEWAY CLIMBING LANE

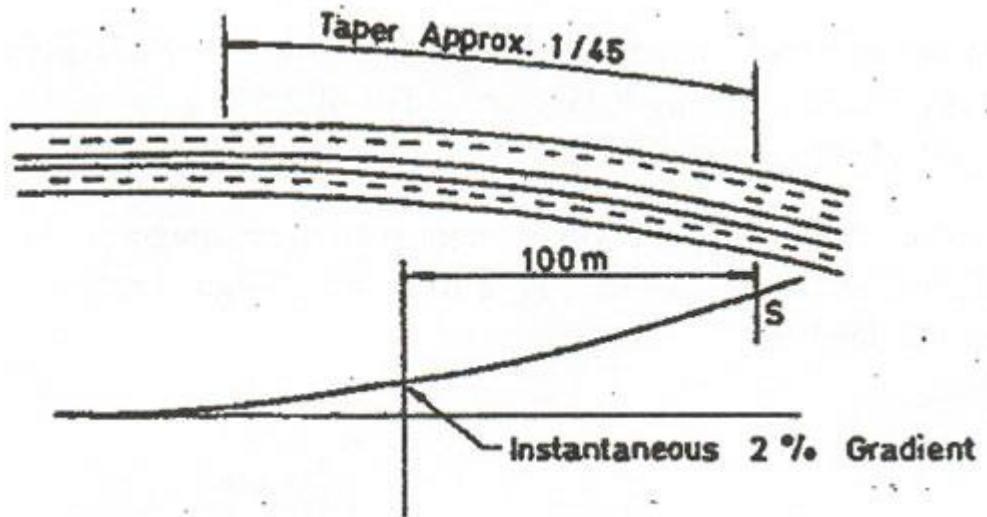
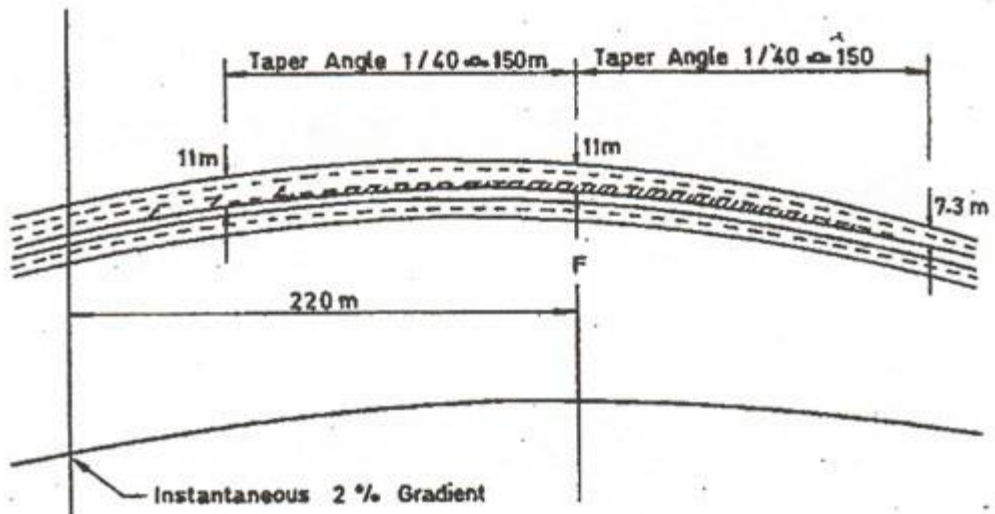

DIAGRAM 3.3.9.4 : END OF DUAL CARRIAGEWAY CLIMBING LANE



3.4 The Road in Cross Section

3.4.1 Cross fall

3.4.1.1 Except on curves where super elevation or elimination of adverse cross fall is required, carriageways should normally have a cross fall of 2.5% from the crown or central reserve downhill towards the side of the road.

3.4.1.2 At the junction of a minor road with a major road the carriageway of the minor road should be graded into the channels of the major road, which should retain its normal cross-section throughout the junction.

3.4.2 Carriageway Widths in Urban Areas

3.4.2.1 The carriageway widths for various types of road are given in Table 3.4.2.1.

Table 3.4.2.1
Minimum Carriageway Widths in Urban Areas

Road Type	Single Carriageway		Dual Carriageway		
	2 lane (m)	4 lane (m)	2 lane (m)	3 lane (m)	4 lane (m)
Trunk Road / Expressways	--	--	7.3	11	14.6
Primary Distributor	--	--	6.75	10	13.5
District Distributor	7.3 or 10.3	13.5	6.75	10	--
Local Distributor	7.3 or 10.3	13.5	6.75	--	--
Industrial Road - Principal Access	--	13.5	6.75	--	--
Industrial Road - Secondary Access	7.3 (one way) 10.3 (two way)	--	--	--	--
Cargo Handling Areas - Access Road	8 - 10.0	--	--	--	--

3.4.2.2 The width of trunk road carriageways may be reduced below that given in Table 3.4.2.1 if this can be justified on economic or other grounds.

3.4.2.3 Where there are Tram Tracks a 5.5m wide tram reserve must be allowed for a double track system.

3.4.2.4 With regard to Light Railway Systems, i.e. North West Railway, certain standards have been evolved as a result of the *Tuen Mun Light Rail Study* and this should be referred to if information on Light Rail Reserves is required. Where a Light Rail system is to be segregated from the carriageway it is important that sufficient clearance is provided between any obstruction on the Rail Reserve and the edge of the carriageway. To achieve this it may be necessary to provide a verge or marginal strip as part of the highway.

3.4.2.5 Where a chain of refuges or tram platforms is used to separate opposing traffic streams the overall width of the carriageway should be increased to accommodate the refuges and platforms.

3.4.2.6 On District Distributor Roads, Local Distributor Roads and Industrial Access Roads, if loading/unloading activities are to be permitted from the carriageway, an additional 3m wide parking strip should be provided wherever possible to avoid the loading activities interfering with the through traffic flow. The parking strip should be terminated prior to any junctions, and if not marked out in bays an edge of carriageway broken line marking should be used to separate the parking strip from the carriageway.

3.4.2.7 The division of two way single carriageways into three lanes, either in the form of two lanes serving one direction and one lane serving the other, or, having a common centre lane used for overtaking in both directions, is not appropriate for roads in the Territory and therefore must not be employed. The reasons for this being that such configurations are potentially dangerous in respect of :

- (i) Where the carriageway is divided into two lanes in one direction and one lane in the other, vehicles in the single lane attempting to overtake slower moving vehicles, even where the double white line system is employed , by moving into the fast lane of traffic approaching in the opposite direction.
- (ii) Where the centre lane is used as a common overtaking lane by traffic in both directions, vehicles overtaking slower vehicles moving into the path of vehicles overtaking in the opposite direction.
- (iii) Vehicles making right turns from premises fronting the road having to anticipate at the same time, both, gaps in the lane or lanes of traffic immediately adjacent to their side of the road, and gaps in the lane or lanes of traffic in the opposite direction.
- (iv) Vehicles making right turns into premises fronting the road obstruction traffic behind them, and in the case of turning from the single lane, because this will bring all following traffic to a halt, causing the turning driver to attempt to negotiate gaps in the opposing traffic which are too small, and in the case of vehicles turning from the two lane direction being in the path of faster moving traffic which have been using this lane to overtake slower moving traffic.

3.4.2.8 The exception to paragraph 3.4.2.7 will be in the situation where on a steep gradient, an additional climbing lane is required to be provided in accordance with section 3.3.8 of this chapter. However in urban areas, roads of this nature will often have frontage development with access being required into and out of premises at frequent intervals, and also vehicles stopping to service such premises. If the latter is the case, and right turning pockets cannot be provided to protect turning traffic in both directions and/or stopping restrictions cannot be imposed, then it is preferable to have an extra wide two lane carriageway.

3.4.3 Carriageway Widths in Rural Areas

3.4.3.1 Table 3.4.3.1 shows the carriageway widths for the various road types in rural areas.

Table 3.4.3.1
Minimum Carriageway Widths in Rural Areas

Road Type	Single Carriageway		Dual Carriageway		
	2 lane (m)	4 lane (m)	2 lane (m)	3 lane (m)	4 lane (m)
Trunk Roads	--	--	7.3	11	14.6
Rural Roads	7.3	14.5	7.3	--	--
Feeder Roads	6	--	--	--	--

3.4.3.2 For Trunk Roads and Rural Roads lesser widths may be used if these can be justified on economic or other grounds.

3.4.3.3 If foreseeable development will change the function of a road to that of a different type then the standard for this latter type should be adopted at the initial design stage.

3.4.3.4 Additional parking strips will not normally be justified in rural areas, but if for any reason they are to be provided similar standards to that for urban areas as mentioned in paragraph 3.4.2.6 should be used.

- 3.4.3.5 For the same reasons given in paragraph 3.4.2.7 in respect of urban areas, two way single carriageways in rural areas must not be divided into three lanes, other than on steep gradients, for the purpose of providing an additional climbing lane, and then only strictly in accordance with section 3.3.8 of this chapter. Where a climbing lane is proposed, right turning pockets with local widening must be provided, for both directions, if right turning movements are to be permitted in to any premises fronting the road.

3.4.4 Widening on Curves

- 3.4.4.1 Where curves of radius of 400m or less are used carriageway widths should be increased in accordance with Table 3.4.4.1.

Table 3.4.4.1
Appropriate Carriageway Widths on Curves (m)

<u>Curve</u> <u>Radius(m)</u>	<u>2 lane</u>				<u>3 lane</u>		<u>4 lane</u>	
	<u>6m</u>	<u>6.75m</u>	<u>7.3m</u>	<u>10.3m</u>	<u>10m</u>	<u>11m</u>	<u>13.5m</u>	<u>14.6m</u>
< 150	7.3	7.9	7.9	11.9	11.9	11.9	15.8	15.8
150 < 300	7	7.3	7.3	11	11	11	14.6	14.6
300 < 400	6.9	7.3	7.3	10.3	11	11	14.6	14.6

- 3.4.4.2 The widening should be achieved by increasing the width at a uniform rate along the length of the transition curve on the inside of the curve.
- 3.4.4.3 Lane widths for slip roads at curves will be given in the relevant section on Junctions.

3.4.5 Service Roads

- 3.4.5.1 Table 3.4.5.1 indicates the carriageway widths to be used for service roads.

Table 3.4.5.1
Carriageway Widths of Service Roads (m)

<u>Carriageway Type</u>	<u>Cars Only</u>	<u>All Vehicles</u>
One Way	4.5	5.5
Two Way	5.5	6.75
Industrial Fire Escape & Rear Service Road	-	7.3

- 3.4.5.2 For service roads less than 6m in width, an overall width, when clear of any obstructions, of at least 6m, but which may include adjacent kerbs, footways or verges, must be provided to allow fire service appliances to operate in the event of emergency.
- 3.4.5.3 Service roads, which are sometimes provided to reduce the number of points of access on to a major road, should only be considered when the alternative of providing a rear access road system connecting to the major road through proper junctions is found to be impracticable. Where such service roads are provided careful attention needs to be given to the junction arrangement of the service road with the main road and any side road as because of the restricted visibility of traffic on the service road these junctions can have a high accident risk potential. Consideration should be given to reducing as far as possible likely traffic conflict points.
- 3.4.5.4 The verge between the main carriageway and the service road should generally be 2m in width and never less than 1.5m. Additional local widening may be necessary however in the vicinity of junctions.
- 3.4.5.5 Fire Escape and Rear Service Roads in Industrial Areas should be 7.3m in width.

3.4.5.6

Details of turning areas are given in Diagrams 3.4.5.1 & 3.4.5.2. However Chapter 2, and Chapter 4 should also be referred to if there is any doubt as to the adequacy of the areas in terms of the type of vehicles likely to use them.

DIAGRAM 3.4.5.1 : MINIMUM TURNING TEE FOR HEAVY GOODS VEHICLES
AND TURNING CIRCLE FOR CUL - DE - SAC
MINIMUM TURNING TEE USE BY WHERE FREQUENT HEAVY
GOODS VEHICLES OCCURS

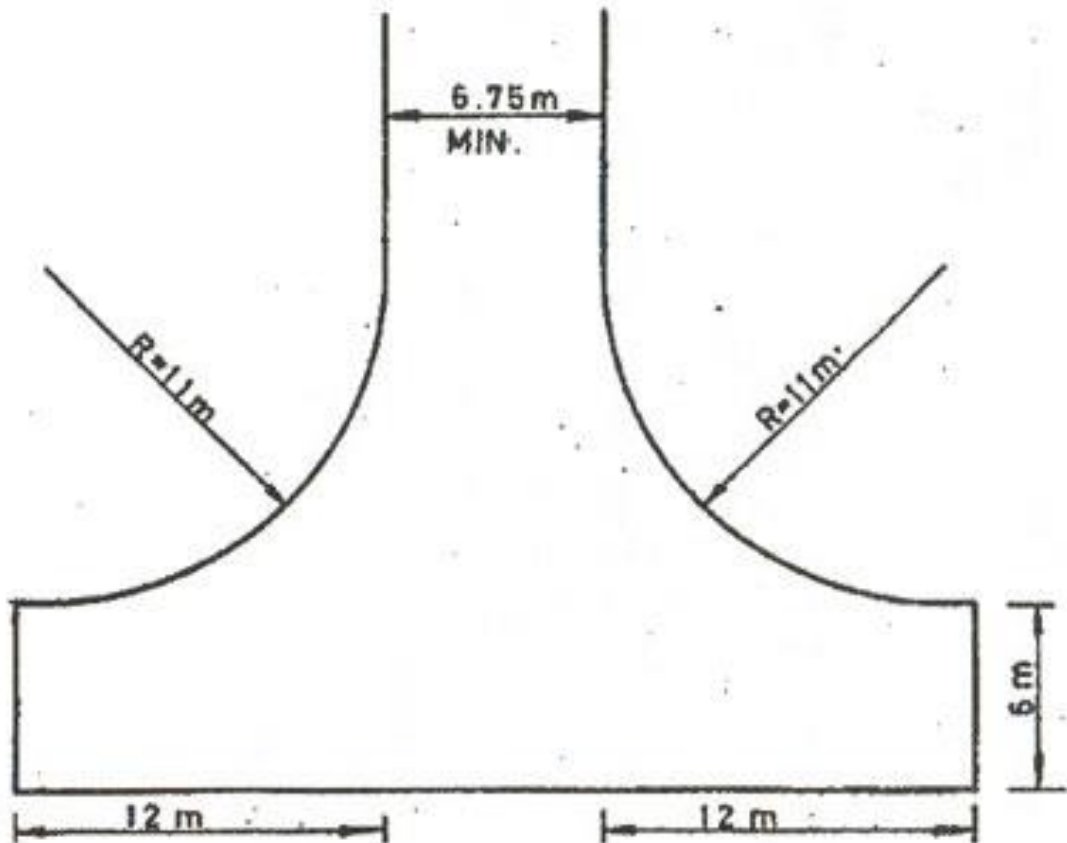

IF THE PROPORTION OF ARTICULATED VEHICLES IS HIGH, A FURTHER INCREASE IN THE DIMENSIONS MAY BE NECESSARY.

TURNING CIRCLE

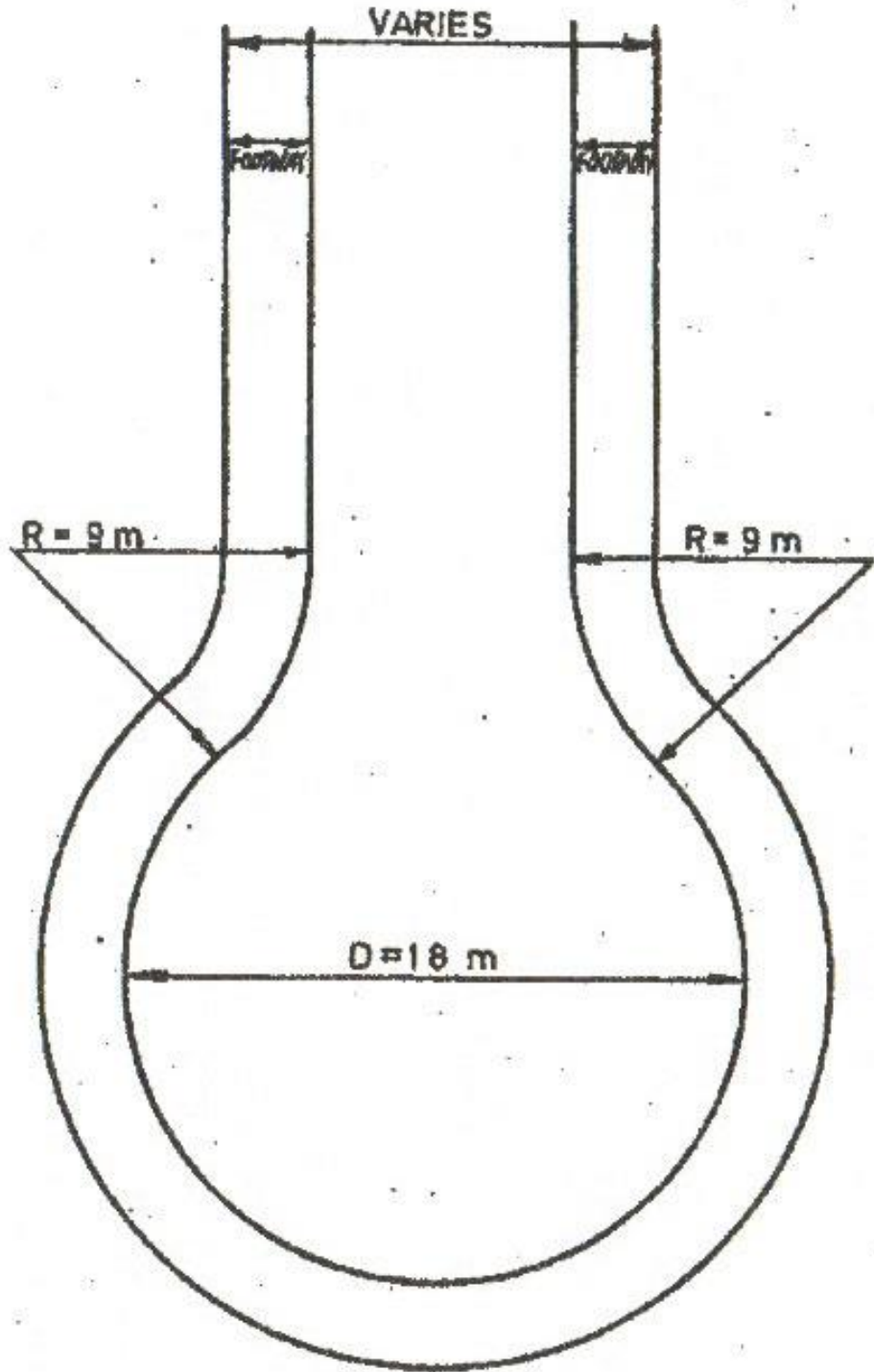

WHERE FREQUENT USE BY HEAVY GOODS VEHICLES OCCURS, THE DIAMETER SHOULD BE INCREASED TO 26m

DIAGRAM 3.4.5.2 : MINIMUM TURNING AREAS
MINIMUM TURNING AREA
FOR LIGHT AND MEDIUM GOODS VEHICLES
(TYPE A)

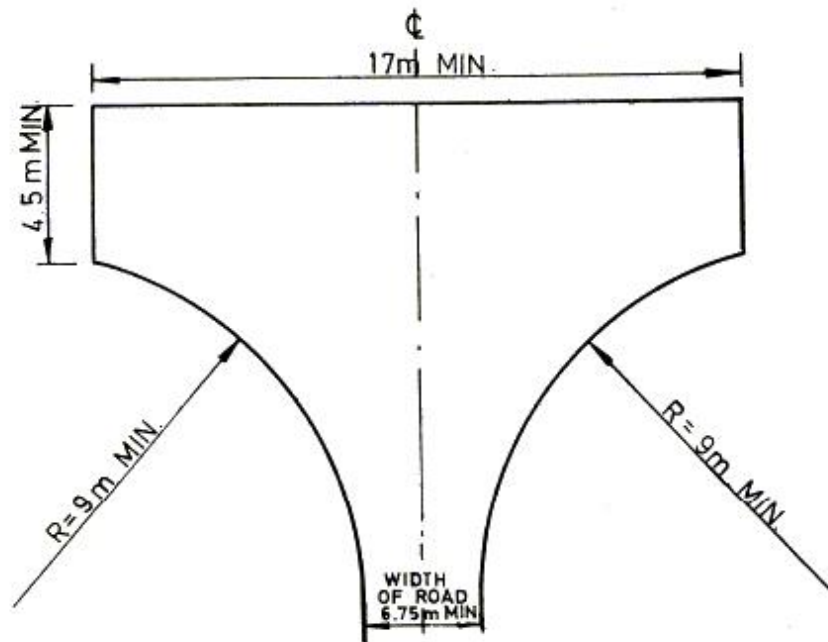

MINIMUM TURNING AREA FOR PRIVATE CARS
(TYPE A)

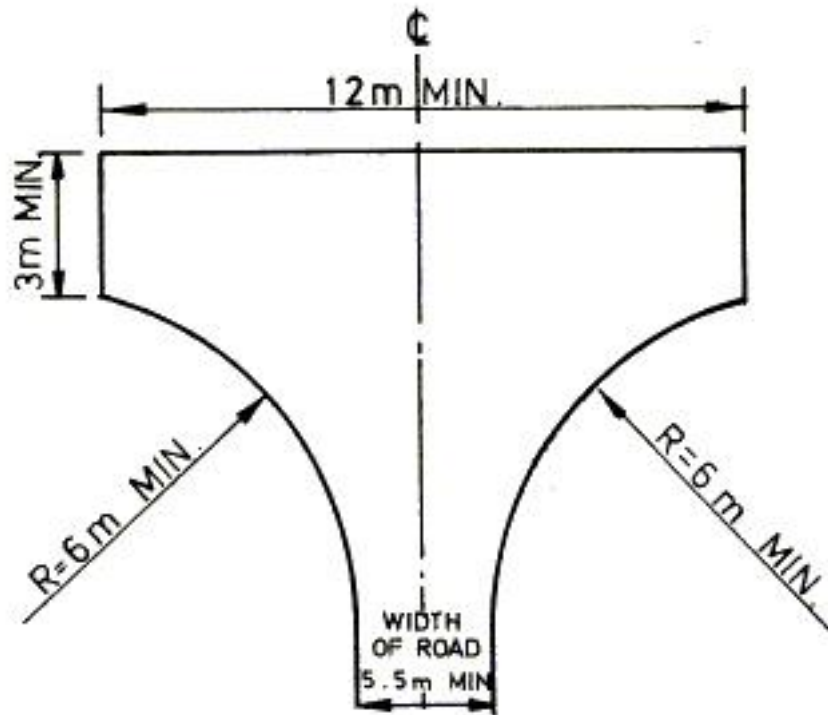

MINIMUM TURNING AREA FOR PRIVATE CARS
(TYPE B)

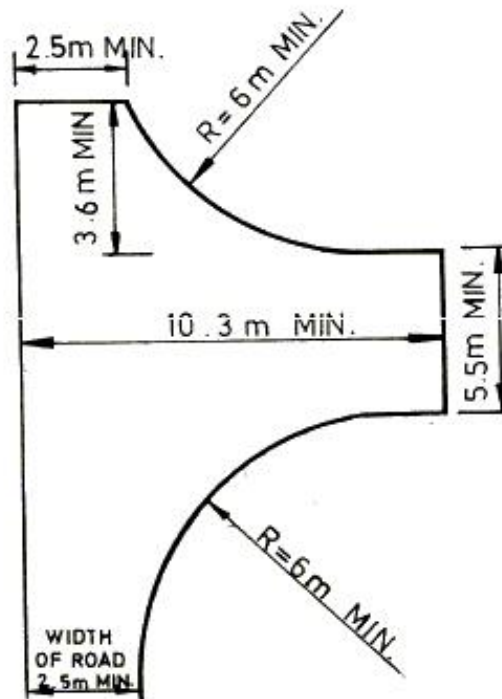

MINIMUM TURNING AREA
FOR LIGHT AND MEDIUM GOODS VEHICLES
(TYPE B)

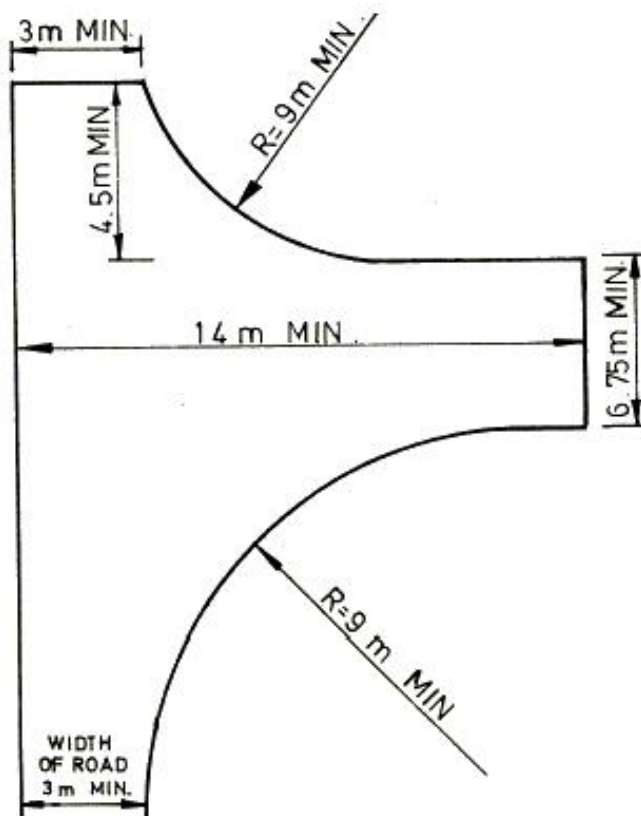

3.4.6 Cargo Handling Areas

3.4.6.1 The cross section for public cargo working area (PCWA) will depend on the width of the PCWA and the type of cargo to be handled. The minimum width of a PCWA is 50 metres. The arrangement of a cross section is as follows :

<u>Purpose</u>	<u>Width(m)</u>
Working apron	10 - 24
Traffic Lane	8 - 10
Backing area	12 - 36

3.4.7 Central Reserves and Traffic Islands

3.4.7.1 On two way roads with four or more lanes it is desirable to separate the opposing traffic streams by a central reserve. The width of such a central reserve will be dependent on the road type, the circumstances of the particular location and the type of street furniture to be provided.

3.4.7.2 In urban areas where barrier fences or other street furniture is not required on the central reserve the desirable and minimum widths are 1.75m and 1.25m respectively.

3.4.7.3 Where road traffic signals are to be installed on the central reserve the actual width will be determined by the particular signal arrangement at the location. However, Table 3.4.7.1 gives some guidance as to the minimum width requirements.

Table 3.4.7.1
Minimum Widths of Central Reserves for Road Traffic Signal Installations

<u>Size / Type of Aspects</u>	<u>Minimum Reserve Width</u>	
	<u>With backing board(m)</u>	<u>Without backing board(m)</u>
200	1.65	1.3
300	1.95	1.4
Pedestrian Aspect	--	1.5

3.4.7.4 Where overhead traffic signals are to be installed in the central reserve, the appropriate width will generally be determined by the diameter of the mast and the horizontal clearance requirements of section 3.5. However, the width of the concrete foundations may also influence the position of any kerb surround.

3.4.7.5 If traffic signs are to be mounted on the central reserve normal clearance requirements should be maintained. However, some reduction of these in accordance with paragraph 3.5.2.2 is acceptable in difficult conditions.

3.4.7.6 On Urban Trunk and Primary Distributor Roads, a minimum 500mm wide marginal strip must be provided adjacent to each carriageway as part of the central reserve. This width may be increased to effect any adjustment to the alignment of the barrier fence provided. It can also be assumed for initial design purposes that, the road lighting columns will be located in the central reserve, and the barrier fence to be provided will be a concrete profile barrier fence. The minimum width of the central reserve will be determined by the sum of, the marginal strips, the width required for the lighting column or other street furniture and the width required for the concrete profile barriers. A provisional minimum overall width for the central reserve may be taken as 2300mm but this may need to be adjusted depending on actual mounting details of the lighting columns, gantry signs and traffic signs to allow the standard horizontal clearance shown in paragraph 3.5.2.1 to be achieved.

- 3.4.7.7 For Rural Trunk Roads the same considerations as given to Urban Trunk Roads apply to the central reserve width, with the exception that the marginal strips should be increased to a minimum width of not less than 1000mm. The minimum provisional central reserve width for a Rural Trunk Road, having concrete profile barriers incorporating lighting columns will therefore be 3200mm, subject to the detailed arrangements for mounting the lighting columns and gantry signing. Planting in the central reserve of a Rural Trunk Road should be viewed with caution because of the high traffic speeds that can be generated and the maintenance problems and difficulty of access that can result. However if such planting is considered appropriate a central reserve width of at least 4000mm will be required. Most traffic signs should be able to be accommodated within the 3200mm minimal width without the necessity for further widening.
- 3.4.7.8 On District and Local Distributor Roads and Rural Roads having dual carriageways the width of the central reserve will vary according to the particular circumstances of the route. However in those situations where a concrete profile barrier incorporating lighting columns is considered appropriate marginal strips not less than 300mm wide must be provided adjacent to the barrier. Based on the provision of concrete profile barriers and lighting columns a minimum provisional width for the central reserve may be taken as 1700mm, subject to the detailed arrangements as to mounting requirements for the lighting columns. If planting in the central reserve is required the minimum planting width provided should not normally be less than 1000 mm wide, and it may be appropriate for amenity reasons to replace the concrete profile barrier with a suitable dwarf wall and kerbs. The marginal 300mm strip should however be retained. Where a concrete profile barrier or other barrier is not considered appropriate or necessary paragraphs 3.4.7.2 and 3.4.7.3 will be relevant in respect of the widths for the central reserve. If traffic signs are required to be erected on the central reserves of this type of road the minimum provisions of paragraph 3.5.2.1 must at least be attained.
- 3.4.7.9 Consideration should also be given when determining the widths of central reserves as to the future requirements, if any, of fixed track mass transit systems and elevated road structures.
- 3.4.7.10 Careful attention should be given to the termination of central reservations and traffic islands particularly where turning movements may take place, and adequate road markings and signs in accordance with Volume 3 must be provided in order to direct vehicles past the islands or reservations. For details of barrier fences, refer to Highways Department Standard Drawings.
- 3.4.7.11 If refuge islands are provided for pedestrians at junctions a minimum width of 4.5m should be provided on the exit carriageway and 3.8m on the entry carriageway. The latter may need to be increased to 4.5m if there is a high percentage of heavy goods vehicles. Additionally as shown in Diagrams 3.4.7.1 and 3.4.7.2 the nose of the islands should not generally be closer than 3m to the line of kerbs of the other road forming the junction.
- 3.4.7.12 Parking should not be permitted in the vicinity of traffic islands or refuges at junctions. It is not only because of the danger of masking pedestrians crossing the road but also it can result in vehicles running over the island when manoeuvring past parked vehicles and negotiating the junction, causing damage to street furniture or danger to pedestrians waiting on the island. In many cases it may be necessary to introduce stopping restrictions in the vicinity of junctions.

DIAGRAM 3.4.7.1 : TRAFFIC ISLANDS AT TEE JUNCTIONS

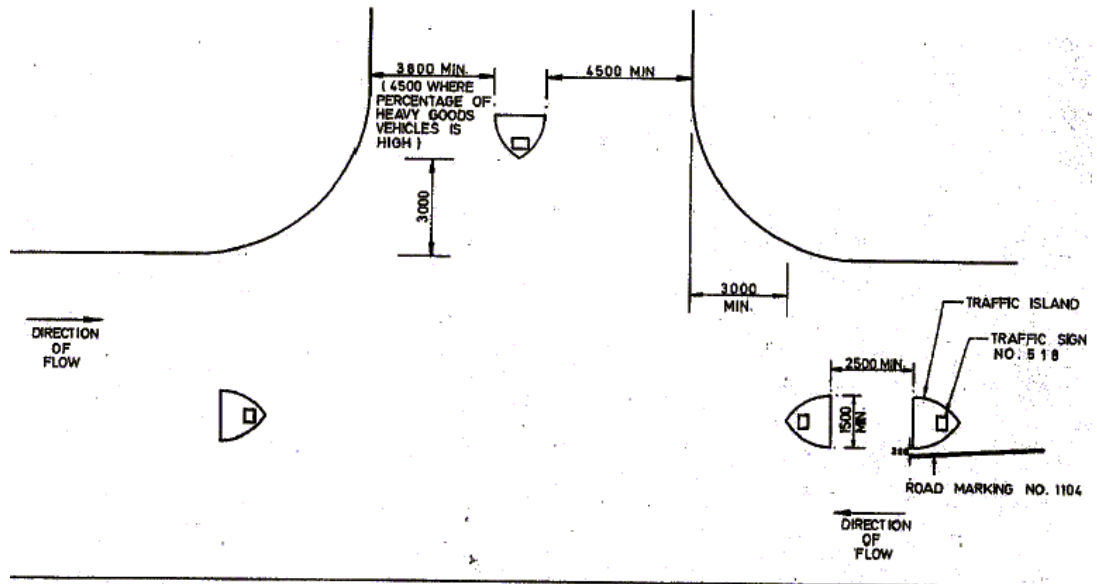

NOTE: ALL DIMENSIONS IN MILLIMETERS

DIAGRAM 3.4.7.2 : TRAFFIC ISLANDS AT 4 - WAY JUNCTIONS

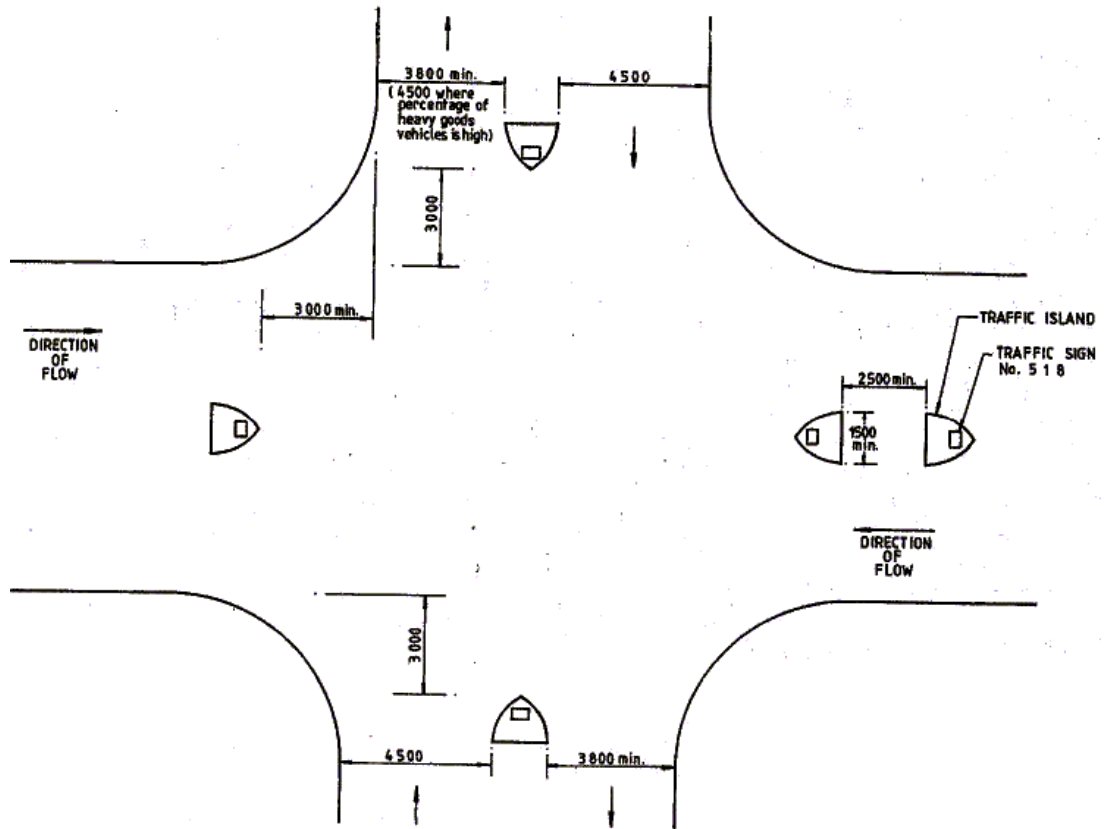

NOTE: ALL DIMENSIONS IN MILLIMETERS

3.4.7.13

Islands, refuges and central reserves less than 1750mm in width should be paved. Whether planting or similar treatment is appropriate where widths are greater than this will depend on considerations mentioned previously, such as the character of the road, the requirements of pedestrians and the location of street furniture.

3.4.8 Emergency Crossings and Contingency Crossings

- 3.4.8.1 An emergency crossing may be defined as opening of 10m in length provided in the central reserve of a dual carriageway road solely for the purpose of emergency vehicles gaining access from one carriageway to another. Careful consideration should be given to the provision of such facilities, as the gaps create particular hazards in the respect that they increase the risk of vehicles encroaching onto the opposite carriageway and that in the event that a vehicle strikes the end piece of any barrier in the central reserve, serious injury or fatality can result to the occupants of that vehicle. The guiding principle should be to minimize the number of emergency crossings provided.
- 3.4.8.2 A contingency crossing at central reserve of a dual carriageway road is considered as serving the purpose of temporary traffic diversion. Removable concrete barriers are normally to be provided at these crossings. As mobilization of plants is required for removing the barriers, opening of the crossing will have to take time. Provision of contingency crossings should be based on agreed contingency plans for major roads. New contingency plans for new major roads should be prepared during planning and design stages of the road projects. The contingency plans should show traffic diversion proposals to cope with traffic incidents and where justified, the locations of proposed contingency crossings at central reserve. Comment and agreement should be sought on the contingency plans from Highways Department, the Police, Transport Department (Strategic Roads Division, Regional Office and Transport Incident Management Section) and other relevant parties. The agreed contingency plans should be provided to Transport Incident Management Section of Transport Department for maintenance.
- 3.4.8.3 Emergency crossing may also serve the purpose of contingency crossing but not vice versa. Hence very strong justification is necessary to position a contingency crossing near an emergency crossing.
- 3.4.8.4 On high speed road (except expressway) where speed limit is 70 km/h or above, with limited access and no frontage development, emergency crossings need not be provided unless intersections are greater than 1.5km apart. If intersections are greater than 1.5km apart and emergency crossings are required, they should generally not be spaced closer than 1.5km apart. Moreover, the emergency crossing should not be located at the bend of the road for safety reason. To determine the exact location, length and number of emergency crossings for a particular scheme, the views of the Police and Fire Services Department should be obtained, and where feasible their requirements should be taken into account.
- 3.4.8.5 On expressways, emergency openings should follow the requirements set out in Section 6.2.1.10 of TPDM Volume 2 Chapter 6.
- 3.4.8.6 For dual carriageway roads other than those described above, emergency crossings should generally be provided approximately at 600m intervals, but again the views of the Police and Fire Services Department should be obtained, as to whether such provision is necessary or not.
- 3.4.8.7 Whenever emergency crossings are required care should be taken that they are not sited such that they would encourage pedestrians to use them as convenient crossing points. For this reason they should not be located opposite bus stops, side road junctions or any point of major pedestrian activity.
- 3.4.8.8 When not in operation emergency crossings should be closed by means of suitably designed barriers which should have been agreed with the Police and Fire Services Department. It is important that such barriers can be removed or knocked down rapidly and easily to make access through the crossing in case of emergency. Further, they should be properly maintained and replaced when damaged.

3.4.8.9 When existing emergency crossings are no longer needed after reviewing in accordance with the guidelines above, they should be regarded as superfluous and can be sealed up after consultation with the stakeholders. In addition, existing emergency crossings identified to be sealed up under the 3km spacing trial scheme should also be regarded as superfluous. Removable concrete barriers should be used to seal up these superfluous emergency crossings to cater for future temporary traffic diversion. However, if it is considered that such contingency arrangement is not necessary, e.g. alternative temporary diversion route is available nearby, permanent concrete barrier can be used instead.

3.4.8.10 Stakeholders should be consulted to obtain comments/agreement on the proposals of emergency crossings and contingency crossings. The following consultation list, which is not necessarily exhaustive, is given for general guidance :

Case 1	Proposals to set up new emergency crossings	The Police, Fire Services Department, Highways Department and Transport Department (Regional Office).
Case 2	Proposals to use removable concrete barriers to set up new contingency crossings	The Police, Highways Department, Transport Department (Strategic Roads Division, Regional Office and Transport Incident Management Section).
Case 3	Proposals to use removable concrete barriers or concrete profile barriers, as appropriate, to seal up superfluous emergency crossings	The Police, Fire Services Department, Highways Department and Transport Department (Regional Office). [Remarks : Transport Incident Management Section of Transport Department should also be consulted if the superfluous emergency crossing also serves as contingency crossing.]

3.4.9 Verges, Marginal Strips and Hard Shoulders

3.4.9.1 A 3300mm wide hard shoulder should be provided on all new Expressways. For details, refer to Volume 2 Chapter 6 of this manual.

3.4.9.2 A 3000mm wide verge incorporating a 1000mm marginal strip should be provided on all Trunk Roads with the exception of elevated structures for which a 1000mm nearside marginal strip should be provided.

3.4.9.3 On elevated dual carriageway Primary Distributor Roads, a 1000mm nearside marginal strip should be provided.

3.4.9.4 Marginal strips should be of the same or similar construction as the carriageway, verges may be suitably hardened.

3.4.9.5 Any barrier fence erected along the nearside verge shall not be closer than 2500mm to the edge of the carriageway.

3.4.9.6 In addition to the other requirements specified in this Chapter, sufficient vertical and horizontal (up to 5100mm) clearances as shown in Tables 3.5.1.1 and 3.5.2.1 should be provided for any noise barrier provided along the edge of the carriageway.

3.4.9.7 Kerbs should not be provided on Trunk Roads as far as possible to avoid more severe consequences caused to errant vehicles when they hit the kerbs. Where kerbs are required along Trunk or Primary Distributor Roads they should normally have a 45 splay and not project greater than 75mm above the adjacent marginal strip.

3.4.9.8 Attention is drawn to paragraph 3.3.5.2 as in locations where radii below R3 are used it may be necessary to increase the width of the verge depending on the design speed value. Also in the vicinity of the Advanced and Final Advanced Direction Signs, it may be necessary to provide a wider verge if an embankment or cutting can not be utilised. If actual sign dimensions are not known a width of 7m from the back of the marginal strip may be taken as a reasonable estimate of the space required, including the minimum horizontal clearance, for Advanced Direction Signs on roads with a Design Speed greater than 80 km/h.

3.4.9.9 On single carriageway elevated roads of whatever type the highway cross section should include for a 1000mm marginal strip on one side and a 500mm marginal strip on the other.

3.4.10 Police Observation Platforms

3.4.10.1 Police observation platforms are raised areas provided for police vehicles to park clear of the carriageway and hard shoulder in order to :

- (i) monitor traffic flow;
- (ii) improve surveillance procedures;
- (iii) reduce response time to incidents on the road;
- (iv) provide a police presence and thereby improve compliance by road users of traffic regulations;
- (v) provide easy access to the main carriageway for enforcement purposes;
- (vi) provide an area off the carriageway where if necessary offending motorists can be interviewed.

3.4.10.2 Police observation platforms should be provided at approximately 2km intervals on each carriageway on all Rural Trunk Roads of 5km or more in length. A staggered arrangement should always be adopted so that the distance between alternate platforms is normally about 1km.

- 3.4.10.3 The location of the platforms will need to be determined in consultation with the Police, which should take place at an early stage in the design procedure. The exact location of the platforms however may not be able to be agreed until the construction stage has been reached when obstructions to visibility can be identified, and will have regard to the following :
- (i) additional land take over can be minimised;
 - (ii) where platform construction costs can be minimised e.g. at changeover points between cuttings and embankments;
 - (iii) maximum unobstructed visibility in both directions from the platform can be provided. Visibility requirements will be related to the spacing of platforms and where possible intervisibility between alternate platforms is advantageous. If not possible either by reason of intervening obstructions or the spacing of platforms is necessarily greater than that given in paragraph 3.4.10.2, a visibility distance of at least 0.8 km in both directions is desirable and priority should be given to the upstream view. But lesser visibility distances below 0.4 km are not acceptable ; Where a platform is to be used in conjunction with a speed detection system, downstream visibility can be shortened to a distance of 0.8 km.
 - (iv) if emergency crossings are provided, the platform should be located upstream of the crossing to ensure that the police vehicles can safely reach it. The platform should not however be located downstream of the emergency crossing as it involves a manoeuvre against the flow of traffic for the police to reach the crossings;
 - (v) where an emergency telephone system is provided it is advantageous to have the platform sited near the telephone. However the telephones should not be sited within the limits of the platform as it will encourage vehicles other than those of the police to use the platforms;
 - (vi) there are certain advantages such as the early detection of unsafe or overloaded vehicles, in siting platforms near slip roads where major diverging, merging or weaving movements take place;
 - (vii) other factors that may also need to be taken into account are :
 - (a) Suitable radio reception qualities.
 - (b) Whether the site could be affected by high cross winds.
 - (c) Platforms should not be sited where the vehicles using them would overlook the privacy of residential property adjacent to the carriageway.
- 3.4.10.4 Where part of the rural trunk road route is provided with a closed circuit television surveillance system, such as in tunnel areas, police observation platforms are not required, though it may be necessary depending on the available verge and marginal strip width to provide lay-bys for enforcement purposes at strategic locations.
- 3.4.10.5 On Rural Trunk Roads less than 5km in length, Urban Trunk Roads and Primary Distributor Roads, police observation platforms are not necessary unless the police make a particular request and the platforms can be justified as part of the necessary surveillance requirements. Lay-bys at suitable intervals may be considered if the verge and marginal strip widths is below that required for enforcement purposes.
- 3.4.10.6 Where police consider the spacing mentioned in paragraph 3.4.10.2 is not required or site constraints make such spacing difficult or expensive to achieve a wider spacing may be adopted.

3.4.10.7

Diagram 3.4.10.1 shows the typical layout of the platform and particular points to note are:

- (i) patrol vehicles must be able to park at right angles to the traffic flow;
- (ii) the exit should be tapered to the rear of the marginal strip;
- (iii) the platform should not be less than 1m above the adjacent carriageway;
- (iv) “Police Only, 警察專用”, should be marked on the surface of the entrance run-in, facing on-coming vehicles, and on the platform;
- (v) construction details must be in accordance with Highways Department standards;
- (vi) drainage must be provided in accordance with Highways Department requirements.

**DIAGRAM 3.4.10.1 : POLICE OBSERVATION PLATFORM
TYPICAL LAYOUT, ELEVATION AND SECTION**

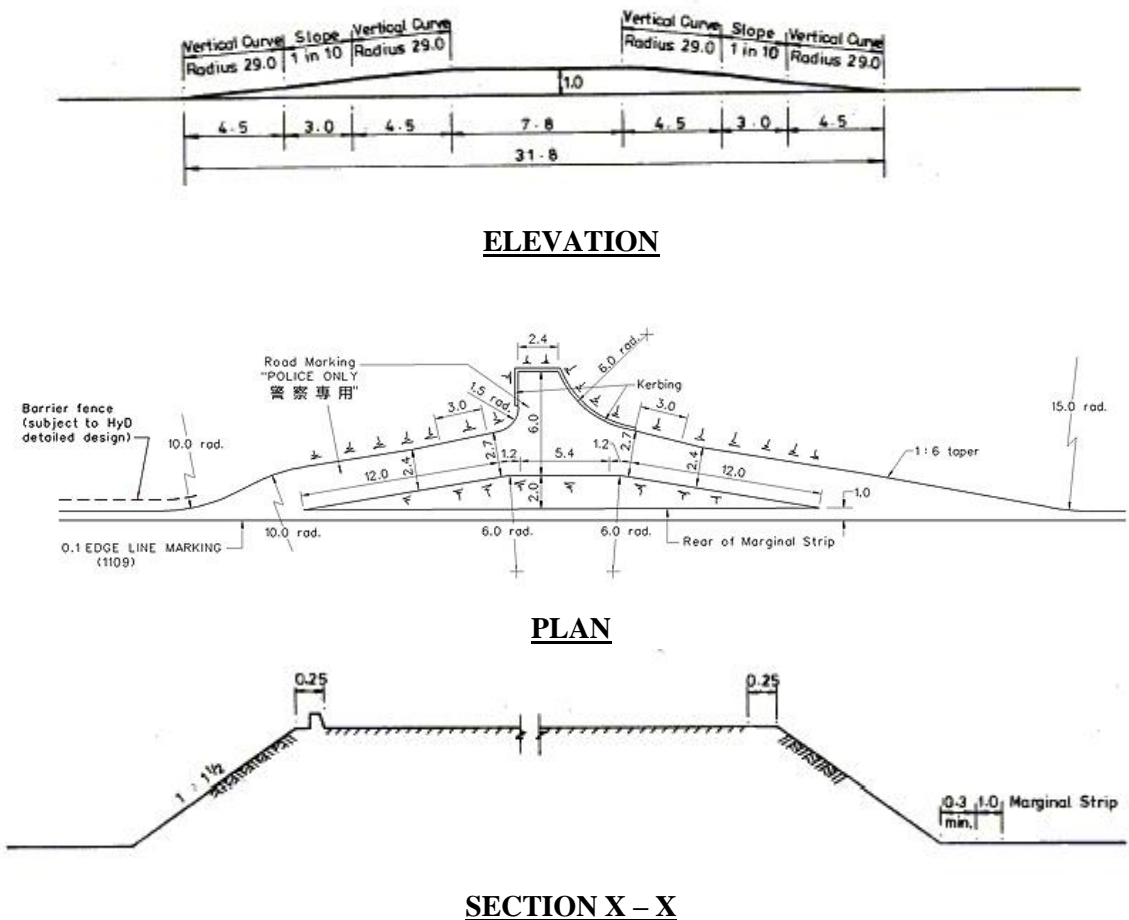

NOTE: ALL DIMENSIONS IN METRES

3.4.11 Footways

3.4.11.1

Footways should be of adequate width to accommodate pedestrian flows, street furniture and additionally to allow reserves for utilities installations and street trees/landscaping.

3.4.11.2

To cater for various functions of footways, it is desirable to adopt a three-zone concept in planning for footway. The concept comprises the "Through Zone" for pedestrian flow, "Street Furniture & Greening Zone" for various street furniture, landscaping, etc, and "Building Frontage Zone" for area adjacent to building frontages. The three-zone concept is indicated in Diagram 3.4.11.1. However, in cases like some existing urban areas, the provision of footway may be subject to severe land constraints. As a result, the provision of "Street Furniture & Greening Zone" and desirable footway width may not be feasible and permitted. Notwithstanding this, opportunities should be sought to increase the footway width to desirable standard when opportunities arise such as:

- (i) to request for set-back of future building lines when OZPs, ODPs, layout plans and area improvement plans are circulated.
- (ii) to request for increase in footway width by set-back of site boundaries when a major housing/residential/commercial development or government development proposal is circulated by Housing Department, Urban Renewal Authority, a private developer, a government department or a railway corporation.

In case that the project proponents/developers cannot be convinced to set back their site boundaries to incorporate a "Street Furniture & Greening Zone" on the footway, they should be asked to consider the alternative of planting trees or including greening proposals within their site boundaries alongside the back of the footway.

DIAGRAM 3.4.11.1 : THE THREE-ZONE CONCEPT OF A FOOTWAY

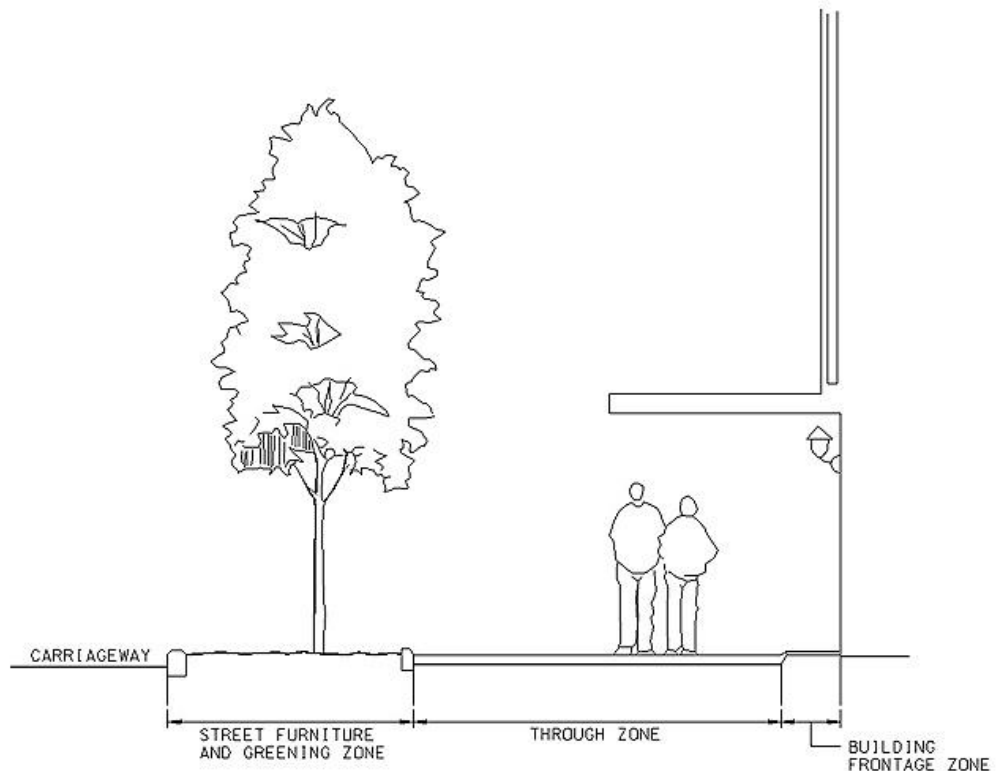

- 3.4.11.3 The Through Zone is the key space available for through movement of pedestrian. It should be of sufficient width to cater for pedestrian flow at a satisfactory level of service (LOS). Highway Capacity Manual (HCM) 2000 can be referred to for details on LOS. Extracted details of the HCM LOS are tabulated in TPDM Volume 6 Chapter 10 Clause 10.5.2.2. LOS C is considered as an optimal level of service in the HCM. In view of the public expectation for a better walking environment, the upper end of LOS C(23 pedestrians/minute/m as stated in the HCM) is preferred. The Street Furniture & Greening Zone(SF&GZ) acts as a buffer between the Through Zone and the road and incorporates landscaping and a variety of street furniture. Building Frontage Zone is the area between the Through Zone and the edge of buildings. It accommodates cross movements into adjacent buildings, areas for browsing and shopping frontages, and provide pedestrians with the additional space when walking along building edge/dead areas.
- 3.4.11.4 Footway zones which allow walking should be constructed with crossfalls between 2% and 3.3% so that they are neither too difficult to drain, nor on the other hand so steep as to make it dangerous to walk upon.

3.4.11.5

The desirable minimum effective widths of footways according to pedestrian volume and type of land use are given in Table 3.4.11.1. While a wider footway is desirable to cater for various street functions, it is more appropriate to provide a reasonable compromise for better pedestrian environment and the scarce land resources, particularly in the existing urban areas. The width shown in Table 3.4.11.1 should be flexibly applied to suit individual circumstance or design. In addition, it should be flexibly increased where practical to accommodate bus bays, urban design feature, etc.

Table 3.4.11.1
Minimum Width of Footways⁽⁵⁾

<u>Land Use Type⁽¹⁾</u>	<u>Through Zone Width / Peak Pedestrian Volume</u> (Pedestrians per minute)	<u>Street Furniture and Greening Zone Width</u>	<u>Building Frontage Zone Width</u>
Commercial Commercial / Residential Residential Zone 1 and those other areas near pedestrian generators such as cinemas, rail stations, some GIC facilities (e.g. schools), etc	4.5m Very High (Over 100)	1.5m ⁽²⁾⁻⁽⁴⁾	0.5m for dead areas and increase to 1m for shopping frontages
Residential Zone 1	3.5m High (80-100)		
Residential Zone 2	2.75m Medium (60-80)		
Residential Zone 3	2.0m Low (Below 60)		
Rural	2.0m Very Low		
Business	4.5m Medium (80)	4m ⁽³⁾⁻⁽⁴⁾	
General Industrial Use	4.5m Medium		
Special Industrial Use	3.5m Low to Medium		
Rural Based Industrial Use	2.5m Low	1.5m ⁽²⁾⁻⁽⁴⁾	

- NOTES:
- (1) For classification of land use, please refer to the HKPSG.
 - (2) The Street Furniture and Greening Zone (SF&GZ) width should be increased to 3m for planting of large trees or understorey planting along boulevards or main roads. The boulevard or main road should have one or more of the following characteristics:
 - as major transport and pedestrian corridors in a district
 - clustering with major community and tourist attractions
 - developing with line of high-grade offices, retail and hotel developments
 - as important district retail street
 - a road of wide scale (e.g. dual 2 or 3 lane carriageway)
 - (3) If a bus shelter exceeding 1m width is provided along the footpath corridor, additional width should be suitably allowed in the SF&GZ.
 - (4) When street furniture exceeding normal object width of 1m (such as artwork) is required, the SF&GZ would need to be widened to cater for its provision.
 - (5) Pending review of Section 3.4 to incorporate other amendments in due course, the minimum width of footways as stipulated in Annex E of Appendix A under TPDM Volume 6 Chapter 10 should be adopted for New Development Areas and for major new development/ redevelopment sites in the existing built-up areas where appropriate. For other developments, the required width of the footways would continue to be considered on a case by case basis, having regard to relevant considerations in Section 3.4.11.

3.4.11.6 Additional widths over those in Table 3.4.11.1 may be necessary if utilities, noise mitigation measures and/or other landscaping features are required. Furthermore, more space should also be allowed for anticipated future development along the road. However where tree grilles or concrete block tree surrounds are used providing that a minimum width of footway, not including the tree grilles, of 2m is available their widths may be included as part of the effective footway width.

3.4.11.7 In Rural Areas, it is preferable to separate footways from the edge of the carriageway by a 1.5m verge.

3.4.11.8 The provision of covers to walkways would shield pedestrians from rainfall and sunshine. In deciding whether covers are required, the following criteria should be considered.

- (i) The walkway should be a main pedestrian link, connecting major public transport facilities including railway terminals / stations, ferry terminals and major public transport interchanges, and the nearest developed or development areas or existing covered pedestrian facilities.
- (ii) For all destinations except public hospitals, the pedestrian flows using the walkway should be at least 3,000 ped/hr for not less than an hour on a weekday. For each public hospital, one covered walkway should be provided to connect to major public transport facilities irrespective of pedestrian flows.
- (iii) The provision of covers may be considered for a length of the walkway up to about 500m.

3.4.11.9 In the design of covers for walkways, consideration should be given to the following requirements:

- (i) The cover should not by itself form any obstruction to firefighting, rescue or other emergency operation that may be required at or near the walkway. Hence, the proposed cover and material to be used should be designed to the satisfaction of the Director of Fire Services and the Director of Highways.
- (ii) The proposal should be vetted by the Advisory Committee on the Appearance of Bridges and Associated Structures (ACABAS) for aesthetic considerations. The need for the provision of a covered walkway should be evaluated against its future impact on the street scene, taking account of street trees and other roadside landscape.
- (iii) If utilities obstruct the construction of covers, the utility companies should be consulted regarding their possible diversion.
- (iv) The proposed cover should not span over road junctions or run-ins if there is headroom or structural problem.
- (v) After installation of covers, the clear width of the walkway should not be less than 3m, particularly at column / footing locations. For walkways that cannot meet this requirement, covers should not be considered unless it is feasible to widen the walkway where necessary. For very wide walkways, the width of covers to be provided has to be decided on an individual basis.
- (vi) Advice from the District Office should be sought on comprehensive public consultation of the proposal.
- (vii) Priority should be given to those locations where there is little opportunity for the public to be sheltered by other features, such as existing building or tree canopies.

3.4.12 Typical Cross Sections

3.4.12.1 Diagrams 3.4.12.1 to 3.4.12.8 illustrate cross sections for the following road types :

- (i) Urban and Rural Trunk Roads
- (ii) Primary Distributor Roads
- (iii) District and Local Distributor Roads
- (iv) Rural Roads
- (v) Elevated Single Carriageway Roads
- (vi) Feeder Roads
- (vii) Service Roads, and
- (viii) Industrial Access Roads

3.4.12.2 Whilst the cross sections are intended to represent typical situations, it may well be necessary to adjust certain of the dimensions to suit the particular circumstances, though very localised adjustments, other than in respect of widening on sharp curves, should be avoided wherever possible.

3.4.12.3

Dimensions which should be regarded as minimal and therefore not subject to any further reduction are those for marginal strips and carriageway widths, though in the case of the latter some reduction in respect of Rural Trunk Roads and Rural Roads may be acceptable. For further details on this and on the other components which form the total road width the relevant sections should be consulted.

**DIAGRAM 3.4.12.1 : TRUNK ROADS
TYPICAL CROSS SECTION**

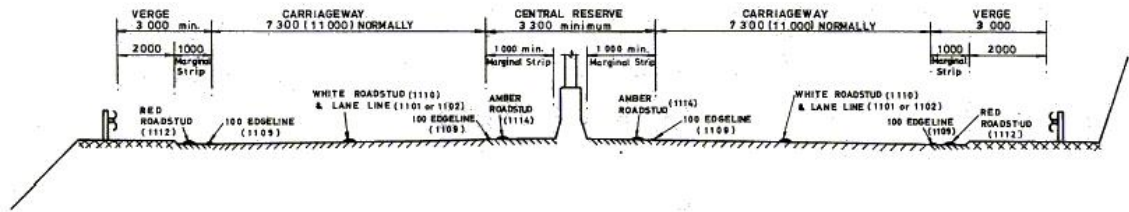

URBAN

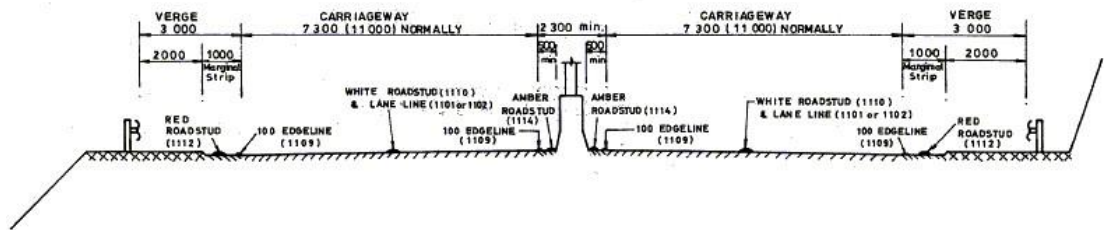

NOT TO SCALE

- NOTES:
1. FOR DETAILS OF ROAD STUDS AND MARKINGS SEE VOLUME 3.
 2. VERGE / MARGINAL STRIP EDGE DETAIL DEPENDENT ON DRAINAGE REQUIREMENTS.
 3. ACTUAL VERGE AND RESERVE WIDTHS WILL BE DEPENDENT ON STREET FURNITURE REQUIREMENTS.

DIAGRAM 3.4.12.2 : PRIMARY DISTRIBUTOR ROADS
TYPICAL CROSS SECTIONS

PRIMARY DISTRIBUTOR ROAD

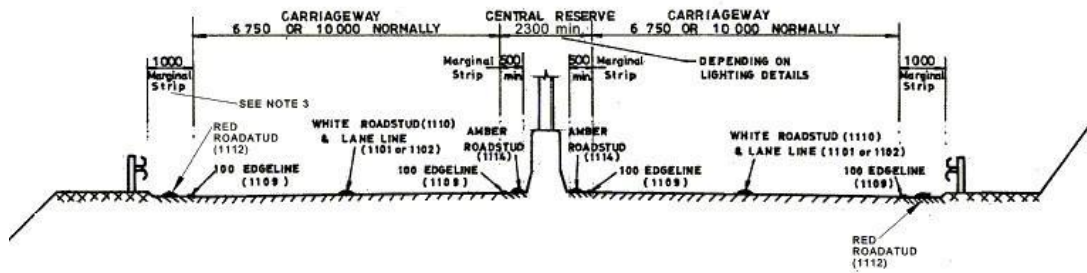

ELEVATED ROAD

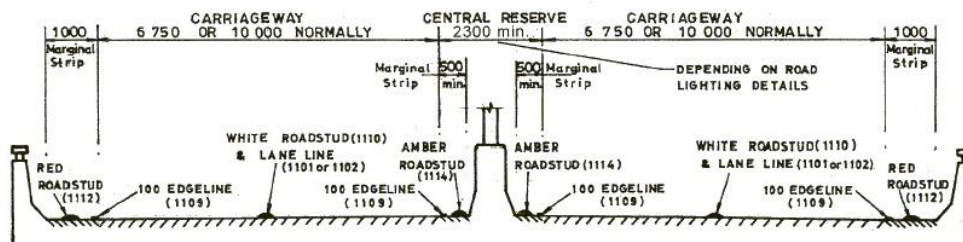

NOT TO SCALE

- NOTES:
1. FOR DETAILS OF ROAD STUDS AND MARKINGS SEE VOLUME 3.
 2. ACTUAL CENTRAL RESERVE WIDTH WILL BE DEPENDENT ON STREET FURNITURE REQUIREMENTS.
 3. MARGINAL STRIP IS ONLY PROVIDED FOR DESIGN SPEED/SPEED LIMIT GREATER THAN 50 km/h.
 4. FOR DETAILS OF FENCE BARRIERS, SEE SECTION 3.9.3

DIAGRAM 3.4.12.3 : DUAL CARRIAGEWAY ROADS
TYPICAL CROSS SECTIONS

DISTRICT AND LOCAL DISTRIBUTOR ROADS

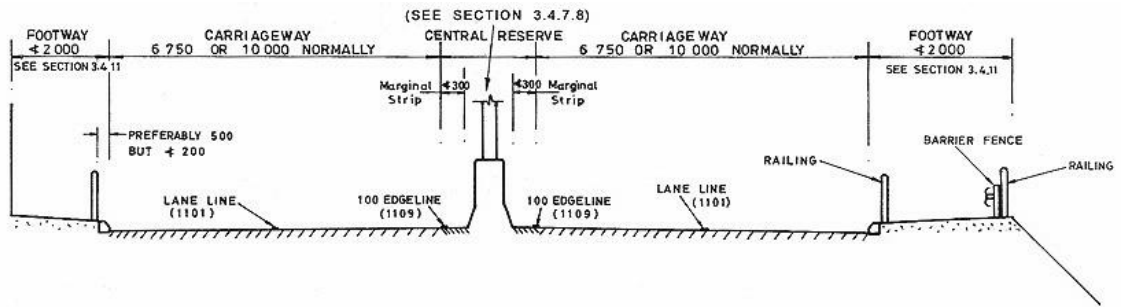

RURAL ROADS

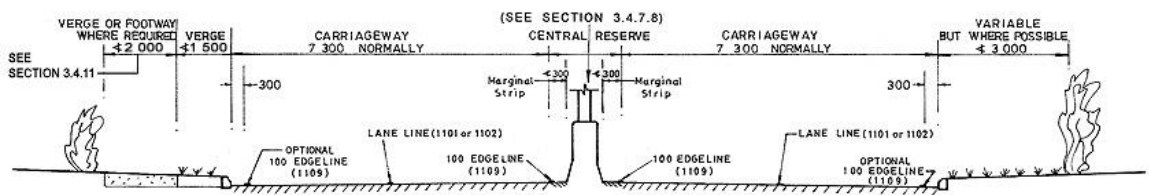

NOT TO SCALE

- NOTES:
1. THE CENTRAL RESERVE CONCRETE PROFILE BARRIER MAY BE REPLACED BY A SUITABLE DWARF WALL AND KERB BUT THE MARGINAL STRIP SHOULD BE RETAINED.
 2. ON LOCAL DISTRIBUTOR ROADS AN ADDITIONAL 3000mm PARKING WIDTH MAY BE PROVIDED ON ONE OR BOTH SIDES.
 3. ACTUAL CENTRAL RESERVE WIDTH WILL BE DEPENDENT ON STREET FURNITURE REQUIREMENTS.

DIAGRAM 3.4.12.4 : 4 - LANE ROADS

TYPICAL CROSS SECTIONS
DISTRICT AND LOCAL DISTRIBUTOR ROADS

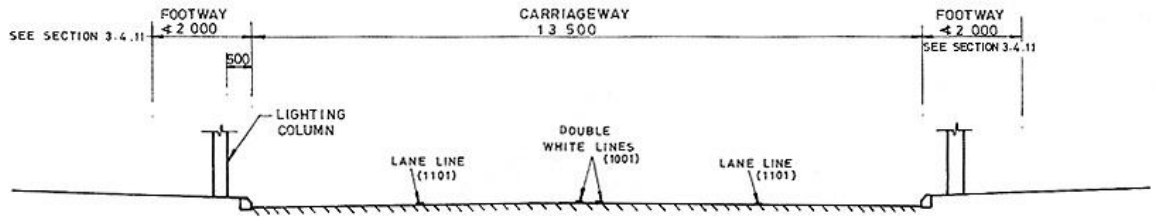

RURAL ROADS A & B

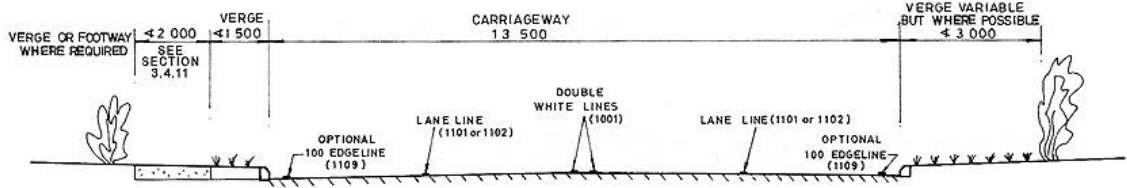

NOT TO SCALE

DIAGRAM 3.4.12.5 : URBAN SINGLE CARRIAGEWAY ROADS
TYPICAL CROSS SECTIONS

DISTRICT OR LOCAL DISTRIBUTOR ROAD

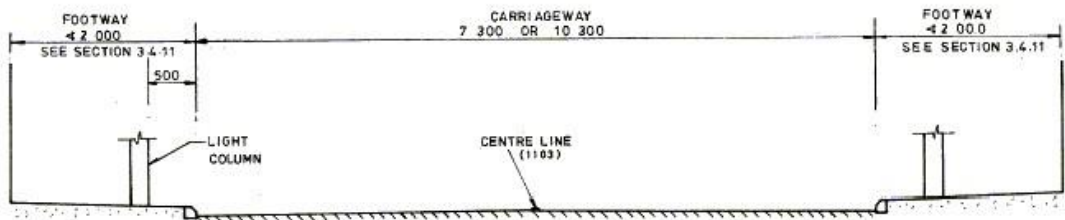

ELEVATED SINGLE CARRIAGEWAY ROAD

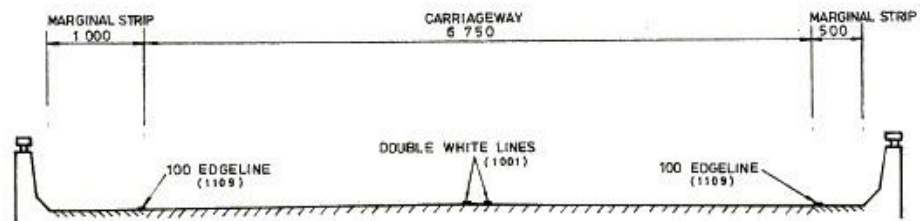

NOT TO SCALE

NOTES: ON LOCAL DISTRIBUTOR ROADS WHERE PARKING IS PLANNED. A 3000mm STRIP SHOULD BE ADDED TO ONE SIDE.

DIAGRAM 3.4.12.6 : RURAL SINGLE CARRIAGEWAY ROADS
TYPICAL CROSS SECTIONS

RURAL ROAD A

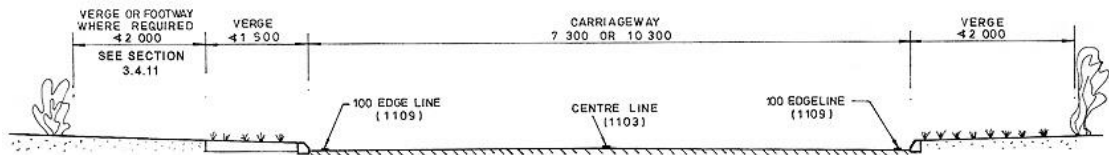

RURAL ROAD B

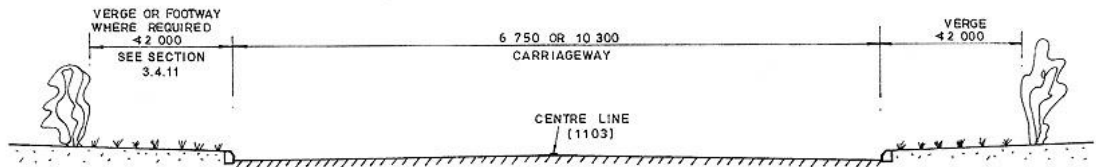

FEEDER ROAD

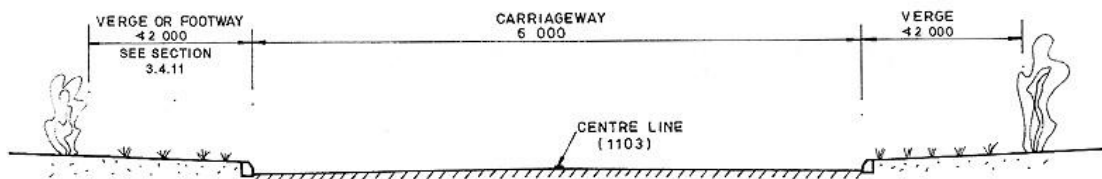

NOT TO SCALE

DIAGRAM 3.4.12.7 : SERVICE ROADS
TYPICAL CROSS SECTIONS

ALL VEHICLES (ONE WAY)

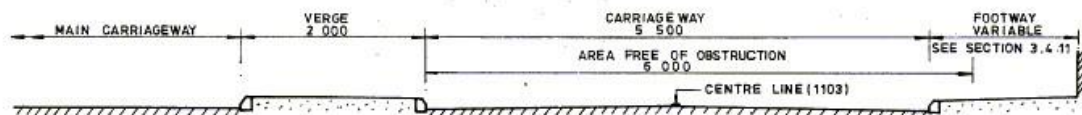

ALL VEHICLES (TWO WAY)

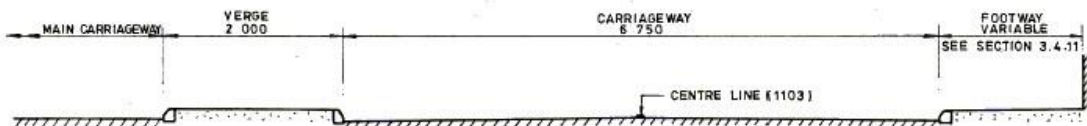

NOT TO SCALE

DIAGRAM 3.4.12.8 : INDUSTRIAL ACCESS ROADS
TYPICAL CROSS SECTIONS

PRINCIPAL ACCESS (TWO WAY)

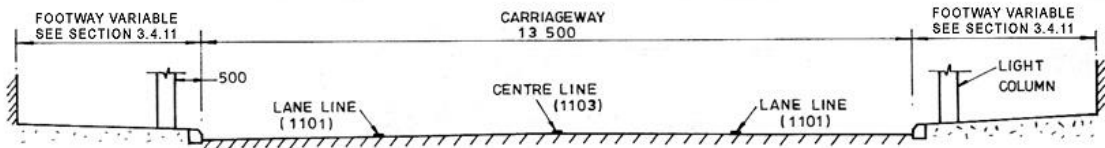

SECONDARY ACCESS (TWO WAY)

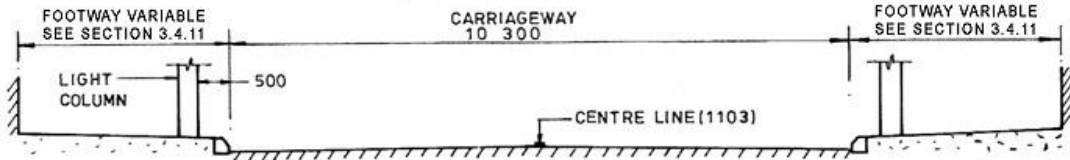

SECONDARY ACCESS (ONE WAY)

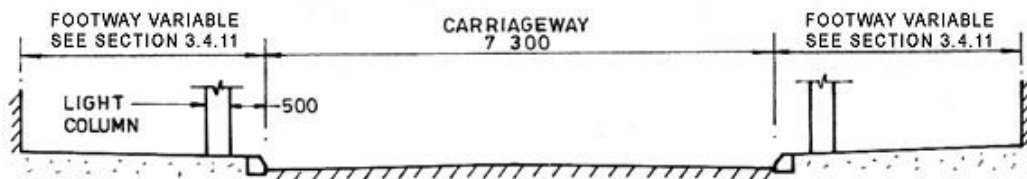

REAR SERVICE ROAD

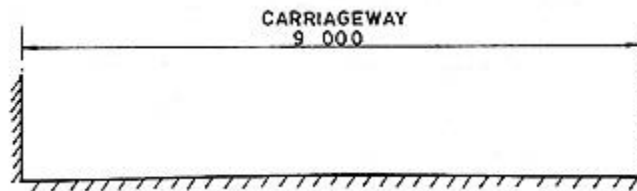

NOT TO SCALE

3.5 Highway Clearances

3.5.1 Vertical Clearances for Structures over Pavements

3.5.1.1 Table 3.5.1.1 gives the minimum vertical clearance to be provided for various structures. The minimum headroom requirements in Table 3.5.1.1 are also the desirable clearances.

3.5.1.2 The clearances given in Table 3.5.1.1. should take into account any street furniture e.g. lighting, traffic signs and signals, which may be attached to the structure.

3.5.1.3 During construction of overhead structures across carriageways clearance may temporarily be reduced to 4.7m, but adequate signing of this must be provided in accordance with Volume 3. Lower clearances should be avoided wherever possible. However, where it is necessary to impose height restriction less than 4.7m, requirements set out in paragraph 5.5.4 of Volume 5 should be followed.

Table 3.5.1.1
Vertical Clearance for Structures over Pavements

Location	Minimum for New Construction (m)	To be Maintained (m)	Beneath Sign Gantries (m)		Beneath North-west Railway Power Wires (m)	
			Minimum for New Construction	To be Maintained	Normal Minimum	When Wires pass under Structures
Over, and within 600mm of a carriageway	5.1	5	5.5	5.4	5.6	Must not be less than 5.4m but actual height will depend on negotiation with MTR
Over a footway but not within 600mm of a carriageway	3.5	3.5			5.6	
In pedestrian subways and enclosed footbridges						
(i) less than 23m in length	2.3	2.3				
(ii) 23m or more in length	2.6	2.5				
In cycle subways or similar						
(i) less than 23m in length	2.5	2.5				
(ii) 23m or more in length	2.7	2.5				
Above tramways	5.6	5.6				
Above North-west Railway	Will generally not be less than 5.8m but will depend on method of construction of structure, and be subject to consultation with MTR, and clearance of 6m or more may be necessary.					

3.5.2 Horizontal Clearances from carriageways

3.5.2.1 Table 3.5.2.1 gives the recommended minimum clearances between the carriageway and obstructions on the footways, verge or central reserve.

3.5.2.2

Although railings, and traffic signs and their posts should generally comply with the requirements of Table 3.5.2.1, on existing footways of District and Local Distributor Roads, Rural Roads and Feeder Roads this may not always be possible without causing considerable inconvenience to pedestrians. In these situations, therefore, railings and signposts may be erected closer to the edge of the carriageway, but no part of the railing, sign or its post should be nearer than 200mm. On Trunk and Primary Distributor Roads and Rural Roads if the hard shoulders, marginal strips and verges are maintained there should be little difficulty in achieving the clearance distances in accordance with Table 3.5.2.1 for traffic signs situated on the nearside of a road. However for a traffic sign located on the central reservation it may be impractical for various reasons to provide the full horizontal clearance and in these situations some reduction may be acceptable but the resulting horizontal clearance should never be less than 450 mm.

Table 3.5.2.1

Horizontal Clearances from the Carriageway to obstructions

Design Speed (km/h)	Height of object	Minimum Clearance where carriageway cross fall is :		
		Away or towards object but not steeper than 2.5% (mm)	Towards object but not steeper than 4% (mm)	Towards object and steeper than 4% (mm)
50 or Less	(i) Less than 3m	500	600	600
	(ii) 3m and above	500	600	800
Above 50 less than 80	(i) Less than 3m	600	600	600
	(ii) 3m and above	1000	1000	1000
80 and above	Any height	1000	1000	1000

3.6 Run-ins and Footway Crossings

3.6.1 Restrictions

3.6.1.1 Wherever possible run-ins should not be permitted on Trunk Roads, Primary Distributors, or District Distributors. In some instances run-ins may have to be accepted because for example, existing lease conditions do not provide powers to restrict access, or in new towns where District Distributor Roads were designed to permit vehicular access.

3.6.1.2 However, where important traffic routes are concerned e.g. trunk roads and primary distributors, and where the public interest might be severely prejudiced by the opening of a run-in, consideration may be given to applying section 16(1)(h) of the *Buildings Ordinance*, although such action is almost certain to result in an appeal by the developer.

3.6.2 Location of Run-ins

3.6.2.1 General

- (i) Run-ins should be sited as far as possible away from junctions, horizontal curves, summit curves, bus stops, zebra or other pedestrian crossings, railway level crossings and other similar locations.
- (ii) Where the lot abuts onto more than one road the run-in should be sited on the least important of these roads
- (iii) For corner lots, it is generally preferable to site run-ins on the downstream side of junctions rather than on the approach side (roundabouts excepted).
- (iv) Normally there should be not more than one run-in and one run-out, combined or separate, on any single frontage.

3.6.2.2 Grade Separated Junctions

Run-ins should be avoided at, or in the vicinity of, grade separated junctions, as they substantially increase the accident potential. Any exceptions must receive special attention to ensure that there is no interference with weaving or merging/diverging movements.

3.6.2.3 Signal Controlled Junctions

Run-ins should not normally be sited within 60m of the stop line on the major road or within 45m on the minor road, on either the approach or exit roads.

3.6.2.4 Roundabouts

Run-ins should not normally be located on the roundabout itself or within 60m on the exit carriageway or 45m on the approach carriageway. In special circumstances these distances may be reduced to 30m and 25m respectively.

3.6.2.5 Uncontrolled Intersections

Run-ins should be located as far as possible away from an uncontrolled junction and preferably not closer than 30m. If there is a likelihood that a junction could be signalised in the future, the distance should be that appropriate to those for signal-controlled junctions.

3.6.2.6 Horizontal Curves and Summit Curves

Run-ins should not normally be located on horizontal or summit curves. If, however, this cannot be avoided, then the visibility distance for vehicles approaching the run-in should preferably be appropriate to the Desirable Minimum Sight Distance given in Table 3.3.5.1, and never less than the Absolute Minimum value.

3.6.2.7 Rear Loading/Unloading Lanes Access should be via a rear loading or unloading lane if one is provided. However, where the size of the development is such as to cause overloading of the rear lane, consideration may be given to access off the public road on to which the lot abuts. On some occasions access from both the rear lane and the public road may be necessary.

3.6.3 **Layout of Run-ins**

3.6.3.1 The width of run-ins should be kept to the minimum compatible with satisfactory operation of vehicles using the run-in. The minimum width should be such that a vehicle can enter the run in from the near side lane without encroachment onto an adjacent lane. Where access by container vehicles is required the width should not be less than 7.3m. Typical layouts for run-ins are shown on Diagrams 3.6.3.1, 3.6.3.2 and 3.6.3.3.

3.6.3.2 Visibility from a run-in should subject to paragraphs 3.6.3.3, 3.6.3.4 and 3.6.3.5 be obtainable between points 1.05m above the road and run-in level over the area described by ABCD in Diagram 3.6.3.4 where :

- (i) AC is a line 4.5m in length measured along the centre line of the run-in from the continuation of the nearer edge of the carriageway of the road to which the run-in has access, and
- (ii) BC and CD, are “x” m in length, and “x” is in accordance with Table 3.6.3.1 and is measured along the nearer edge of the road to which the run-in has access.

Table 3.6.3.1
Length of Visibility Line “x”

<u>Design Speed of Main Road</u> (km/h)	<u>x</u> (m)
80 or over	150
70	130
60	120
50	60

3.6.3.3 For difficult site conditions the length of the line AC in Diagram 3.6.3.4 may be reduced but should never be less than 2m. Such reductions however would not normally be appropriate for Trunk and Primary Distributor Roads.

3.6.3.4 If the road forming the access with the run-in is a dual carriageway road, providing there is no crossing point in the central reserve opposite the entrance or it is a one way road, a single splay, defined by ABC or ADC, depending on the direction of approaching traffic, in Diagram 3.6.3.4 would be sufficient.

3.6.3.5 Parking within the vicinity of run-ins should be avoided wherever possible and of course should never be permitted across the actual entrance. Ideally parking should be prevented throughout the length of the visibility splay but on District, and Local Distributor Roads, Rural Roads and Feeder Roads this may not always be possible to achieve.

3.6.3.6

Traffic signs and other street furniture such as lighting columns will often have to be erected within the visibility splays or may in fact, be already erected. This should not be used as a reason for not permitting a run-in, unless serious interference with sight lines occurs and it is not possible to relocate the item of street furniture in question.

DIAGRAM 3.6.3.1 : DETAILS OF FOOTWAY VEHICLE CROSSING

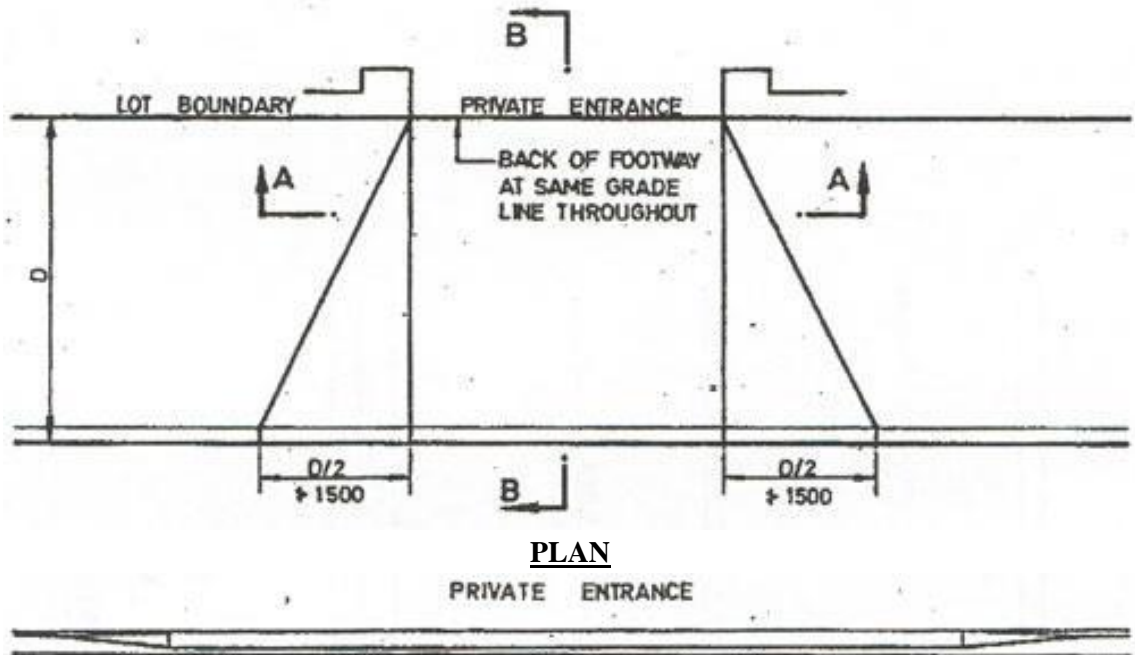

PLAN
PRIVATE ENTRANCE

SECTION A - A

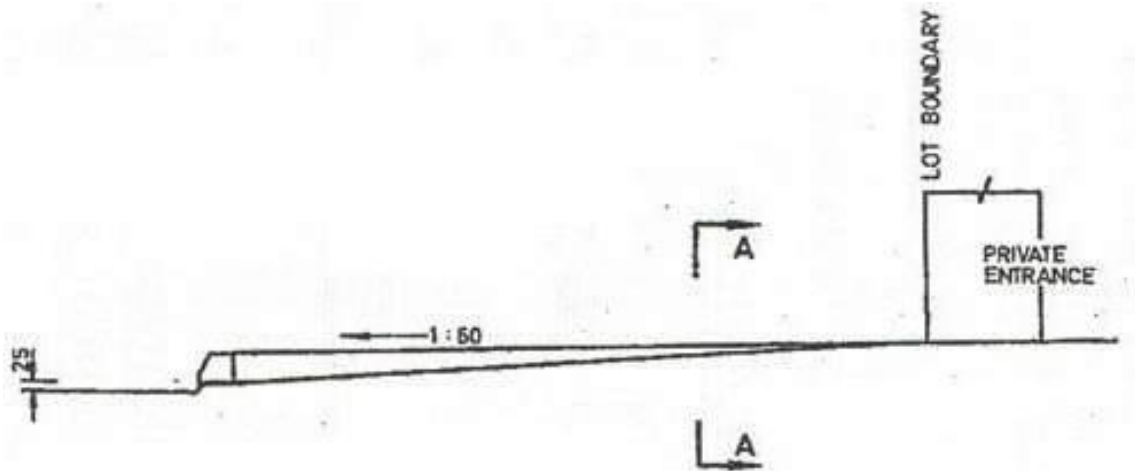

SECTION B - B

NOTE: ALL DIMENSIONS IN MILLIMETRES

**DIAGRAM 3.6.3.2 : FOOTWAY CROSSING FOR VEHICLE ENTRANCE
(FOR SKEW RUN-IN)**

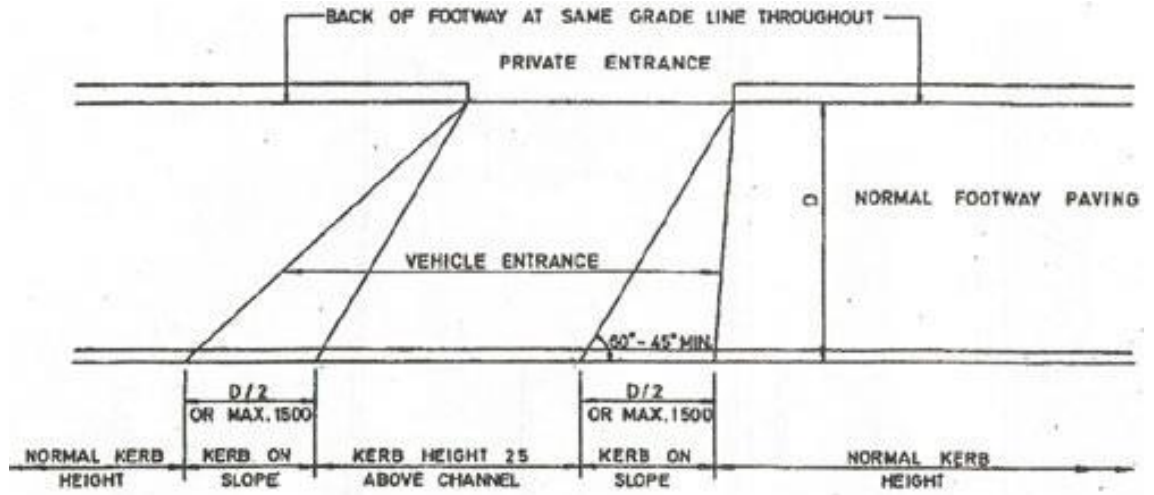

PLAN

ELEVATION OF KERB

NOTE: ALL DIMENSIONS IN MILLIMETRES

DIAGRAM 3.6.3.3 : FOOTWAY CROSSING FOR FILLING STATIONS

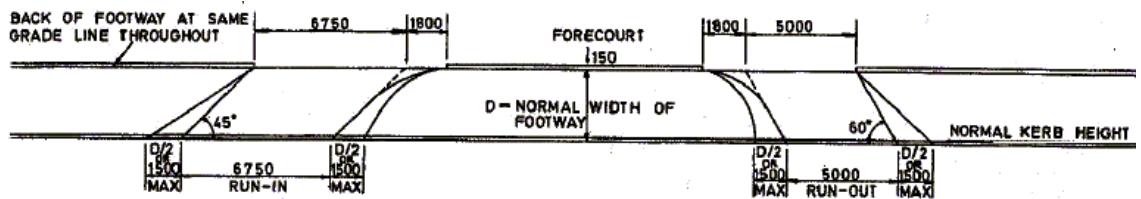

PLAN

NOTE: POSITION OF DUCTS TO BE MARKED ON FOOTWAY THUS C+D

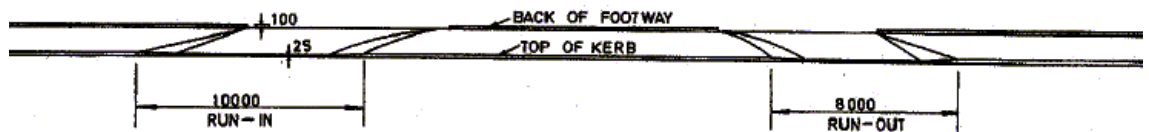

ELEVATION

NOTE: ALL DIMENSIONS IN MILLIMETRES

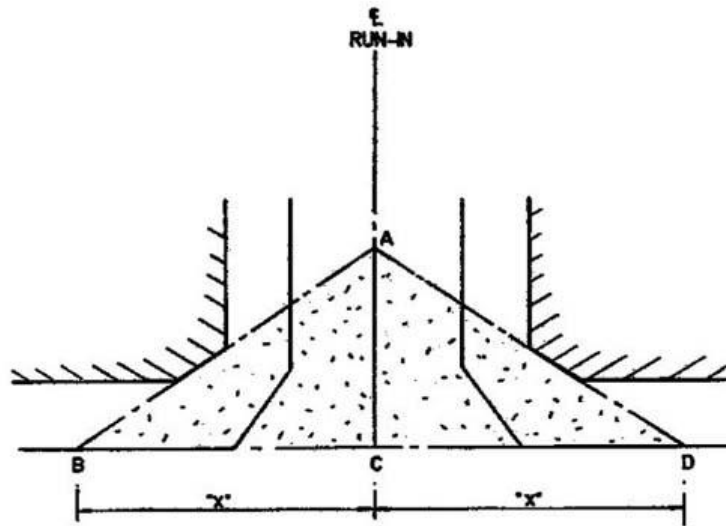
DIAGRAM 3.6.3.4 : VISIBILITY AREA AT RUN-INS**3.6.4 Vehicular access to Short Term Tenancy (S.T.T.) Sites and Short Term Waiver (S.T.W.) Sites**

3.6.4.1 Because it is impractical to ban vehicular access to all STT or STW sites the following guidelines should be used when considering whether access is appropriate or not :

- (i) Trunk Roads
No direct access from an STT or STW to a Trunk Road shall be permitted.
- (ii) Primary Distributors
As a general rule no access direct from an STT or STW; shall be permitted. Direct access will only be considered in exceptional circumstances when all other possible access provisions have been examined and proved impractical. Even then direct access may only be approved if general traffic engineering conditions such as the available sight lines, distance from junctions or pedestrian crossings etc, taking into account the speed and volume of existing or predicted traffic, are acceptable.
- (iii) District Distributors
As a general rule direct access from an STT or STW should be avoided if possible. Direct access will be considered for large sites only if other access provisions have been examined and proved impractical. Even then direct access may only be approved if the location is such that general traffic engineering conditions such as, the available sight lines, distance from junctions or pedestrian crossings etc, taking into account the speed and volume of existing or predicted traffic, are acceptable. The matter of predicted traffic flow in new towns is particularly important as though traffic may be light at the time the matter is under consideration the situation could change rapidly as development proceeds and therefore careful consideration must be given in order not to create precedents or situations which could later prove difficult to cater for.

(iv) Local Roads

Direct access from an STT or STW may be approved if the location is such that general traffic engineering conditions such as the available sight lines, distance from junctions or pedestrian crossings etc are acceptable.

(v) Motorable Tracks (not maintained by Highways Department)

Before agreeing to direct access from an STT or STW consideration should be given to the following factors :

- (a) Size and nature of the proposed STT or STW sites e.g. (factories or storage area).
- (b) Width of the existing track. STT or STW sites should not be considered on single track roads of inadequate width or where the provision of passing bays at suitable intervals is not possible due to site constraints, including structures or private land.
- (c) Need for road improvements. Each case has to be considered on its merits and in some cases it may be necessary to carry out some minor road improvements before such sites can be accepted.
- (d) General traffic engineering conditions, such as available sight lines, distance from junction etc.

3.6.4.2

In the detailed assessment of the location of an access to S.T.T. or S.T.W. sites the traffic engineering aspects referred to in respect of normal run-in requirements in sections 3.6.1, 3.6.2 and 3.6.3 will also be applicable.

3.7 Pedestrian Crossing Facilities

3.7.1 Planning of Pedestrian Crossing Facilities

- 3.7.1.1 A majority of road accidents happen to pedestrians whilst crossing the road. It is therefore essential that proper consideration should be given to providing adequate and safe crossing facilities for pedestrians.
- 3.7.1.2 Complete segregation of pedestrians from vehicular traffic by footbridges or subways is obviously the safest form of crossing. It will also have the advantages of better environment, faster vehicle speed and higher road capacity. Therefore, it is important at the outline planning stage of all new development that proper consideration is given to the provision of such facilities. Even if grade separated crossings could not be justified at the initial stages of the development, consideration may be given to the reservation of land for future provision if appropriate. Notwithstanding the safety and capacity benefits, however, the higher capital and recurrent costs associated with grade separated crossings should be duly taken into consideration.
- 3.7.1.3 The important factor in planning for all pedestrian crossings is that the location ensures maximum potential usage and is as convenient as possible to defined pedestrian paths. Devious routes to crossing facilities or facilities located too far away from pedestrian routes, will lead, in spite of any railings intended to prevent this, to pedestrians creating their own crossing points to the detriment of their own and other road users safety.
- 3.7.1.4 In respect of paragraph 3.7.1.3 Regulation 39 of the Road Traffic (Traffic Control) Regulations does make it an offence for pedestrians to climb through or over any railings, and also to cross the road within 15m of a crossing facility other than at the facility. However it is preferable that such actions be avoided by making the crossing facility the most obvious and direct place to cross rather than relying on police enforcement.
- 3.7.1.5 Guidance as to what type of crossing facility is most appropriate for a particular location is given in subsequent sections. However, it should be noted that substantial capital and recurrent costs, time and effort are needed for construction, operation and maintenance of a grade-separated crossing. A grade separated crossing at or in the vicinity of an at-grade crossing is likely to be under-utilised and therefore not cost effective. Such provision should be avoided as far as possible and should be considered only in exceptional circumstances with extremely strong justifications.

3.7.2 At-Grade Crossings

- 3.7.2.1 At-Grade Crossing are of the following types:
- (i) Zebra Crossings
 - (ii) Light Signal Controlled Crossings
 - (iii) Cautionary Crossing at signal junctions
 - (iv) Uncontrolled cautionary crossings
- 3.7.2.2 At all at-grade crossing points dropped kerbs in accordance with Diagram 3.7.2.1 should be provided to assist the elderly and people with disabilities. The lowered kerbs should be provided for the full width of the crossing, with the ramped kerbs being located outside this width. Under no circumstances should a dropped kerb be continuous around a corner radius as this could lead to vehicles running onto the footway when negotiating the corner, but see also paragraph 3.7.4.10.

- 3.7.2.3 At-grade crossings should not generally be installed on Trunk Roads or Primary Distributors, where pedestrians should be segregated from vehicular traffic. Across Primary Distributors serving also as District Distributors consideration may be given to the use of light signal controlled crossings but no other form of at-grade crossing should be used.
- 3.7.2.4 The width of at-grade crossings should generally not be less than 2.5m nor greater than 9m. Normally the crossing width will vary between 4m and 6m, as widths less than this have been found to be too narrow, and widths greater than this neither possible because of site limitations nor desirable because of the effects on vehicle capacity. Width of 2.5m may be appropriate for uncontrolled cautionary crossings.
- 3.7.2.5 it is important that the crossing width provided is not obstructed by street furniture and that adequate sight lines for pedestrians are available.
- 3.7.2.6 Table 3.7.2.1 gives a guide to appropriate crossing widths in relation to expected flows, and also serves as a first step in the calculation of pedestrian capacity at signal controlled crossing which is explained in Section 3.7.4. It should however be stressed that pedestrian volumes in excess of those indicated for a particular width have been recorded and therefore the table should not be applied rigidly. Volumes in excess of 1200 pedestrians per metre width per hour, will generally be difficult for any at-grade crossing to deal with satisfactorily from both a pedestrian safety and vehicular flow aspect and improvements or alternative means of crossing should be considered when flows are at or above that level.
- 3.7.2.7 Adequate reservoir space must be provided at the edge of the carriageway and on any central refuge, for pedestrians waiting to cross.
- 3.7.2.8 The following factors should be considered when assessing whether a zebra crossing or a light signal controlled crossing should be provided:
- (i) the surveyed pedestrian/vehicle flows conflict;
 - (ii) the current accident record; and
 - (iii) the benefits to pedestrians in terms of convenience, safety and reduced delay against any additional delay incurred by vehicle occupants.

**DIAGRAM 3.7.2.1 : RAMPING OF KERB AND FOOTWAY
AT DESIGNATED PEDESTRIAN CROSSINGS**

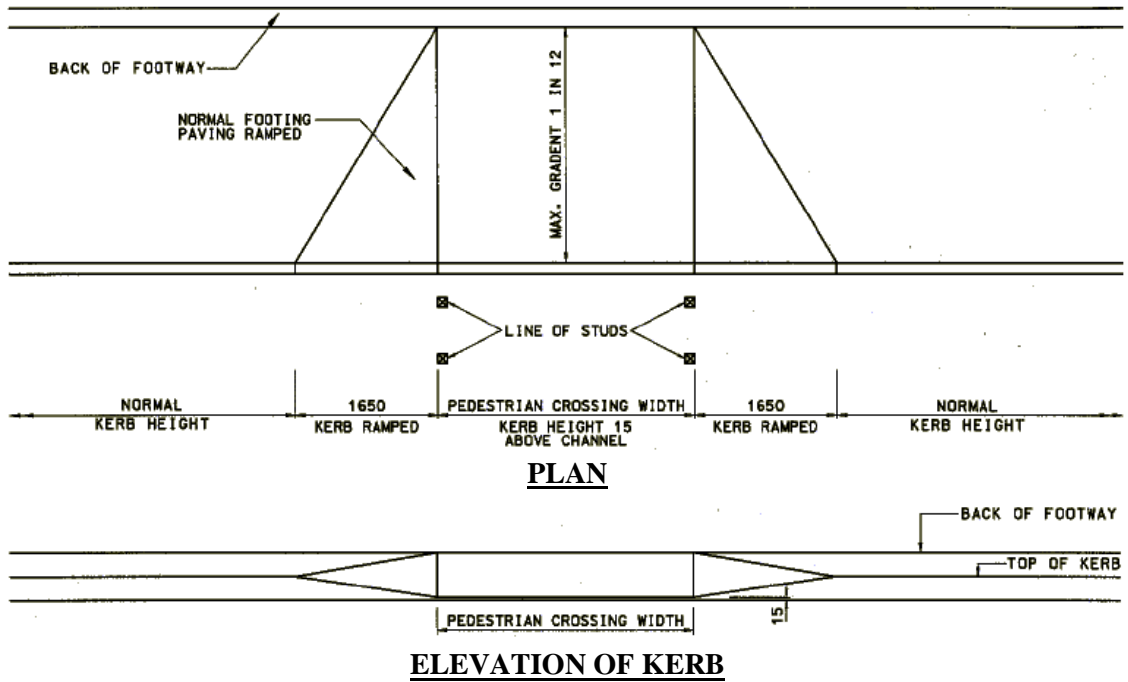

NOTE: ALL DIMENSIONS IN MILLIMETRES

Table 3.7.2.1
Crossing Widths

According to Approximate Pedestrian Flows

<u>Crossing Width(m)</u>	<u>Pedestrians Per Hour Both Directions</u>
2.5	1500 - 3000
4	2400 - 4800
5	3000 - 6000
6	3600 - 7200
7	4200 - 8400
8	4800 - 9600
9	5400 - 10800

3.7.2.9 Guidelines for the provision of a zebra crossing and a light signal controlled crossing are given in sections 3.7.3 and 3.7.4 respectively.

3.7.3 Zebra Crossings

3.7.3.1 The road markings for the crossing and the controlled area are shown in Diagrams 3.7.3.1 and 3.7.3.2 respectively. Further information on these markings and how they are formed are given in Volume 3.

3.7.3.2 Zebra crossings have the advantage of being the simplest and cheapest controlled crossing to install and operate, generally enabling the pedestrian to cross a road safely and with minimum delay.

3.7.3.3 The disadvantage of zebra crossings is that they may be disruptive to vehicular traffic causing considerable delays if pedestrian flows are heavy. Therefore, they may also be less safe for pedestrians and should not normally be installed in the following situations:

- (i) On Trunk Roads and Primary Distributor Roads.
- (ii) When the speed limit of a road exceeds 50 km/h.
- (iii) When the approach road before the zebra crossing has a downhill gradient of 4% or steeper for a length of 100m or more.
- (iv) When traffic signals on either side of the location of the proposed zebra crossing are linked or form part of an ATC system.
- (v) When the proposed location is at close proximity to a roundabout of small radius.

3.7.3.4 The provision of zebra crossings on District Distributor Roads and Rural Roads should be treated with discretion as conditions such as high vehicle approach speeds or heavy traffic volumes may not be appropriate for these crossings.

3.7.3.5 The following quantitative criteria may be used, subject to paragraph 3.7.3.6, as a guide to whether a zebra crossing is appropriate or not for roads not affected by the criteria in paragraph 3.7.3.3.

- (i) Where a central refuge is not to be provided,
 $PV^2 > 10^8$
 where, P = No. of pedestrians per hour averaged over the six highest hours,
 and V = No. of vehicles per hour averaged over the six highest hours and is > 600
- (ii) Where a central refuge is provided,
 $PV^2 > 2 \times 10^8$,
 where P and V are as defined in (i) but in this case $V > 800$.

DIAGRAM 3.7.3.1 : INDICATION OF ZEBRA PEDESTRIAN CROSSING

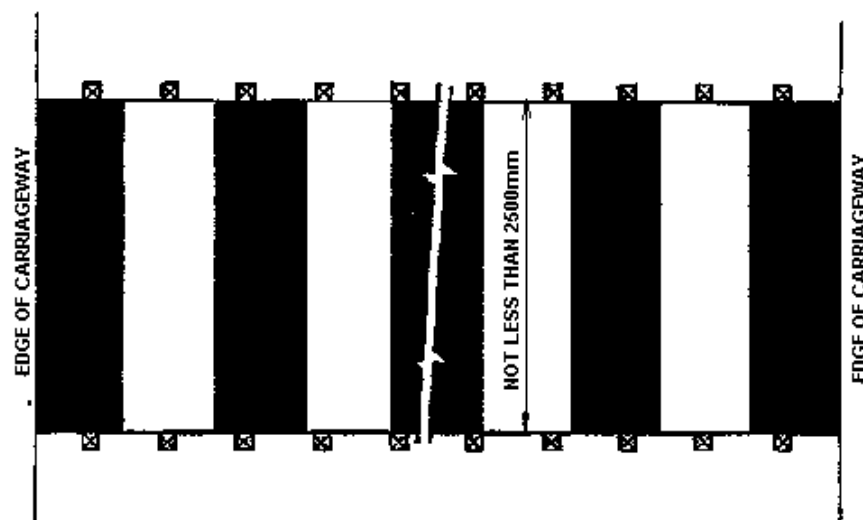

NOTE: DIMENSIONS TO BE IN ACCORDANCE WITH REF. 18.

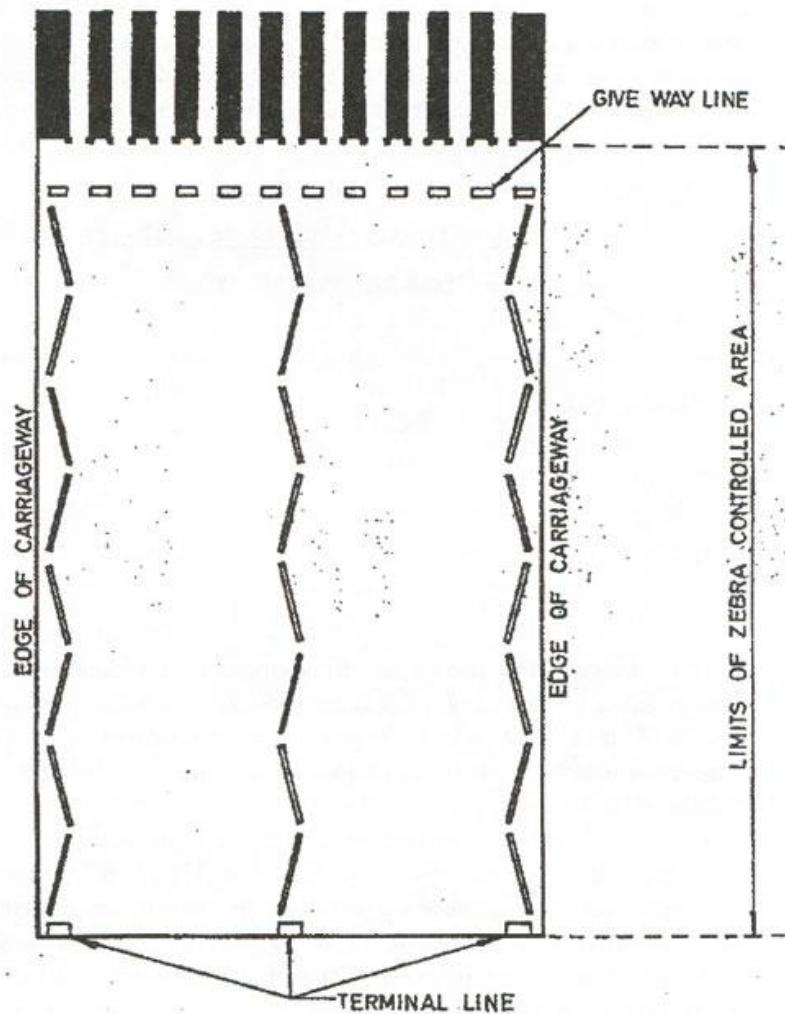
DIAGRAM 3.7.3.2 : INDICATION OF ZEBRA CONTROLLED AREA

PATTERN OF LINES ON ONE OR BOTH SIDES OF A CROSSING INDICATING ZEBRA CONTROLLED AREA.

NOTE: DIMENSIONS TO BE IN ACCORDANCE WITH REF. 18.

3.7.3.6

In rural areas in the New Territories, and in some urban areas, conditions sometimes exist where the criteria mentioned in paragraph 3.7.3.5 could not be obtained, because of the low level of pedestrian use. However for safety reasons an uncontrolled cautionary crossing would not be appropriate and therefore in these locations the criteria given in Table 3.7.3.1 may be used. Care however should be exercised in the use of the table, and it should be established that there is a genuine need for a zebra crossing. Proliferation of zebra crossings particularly where pedestrian flows are light may lead to a debasement of the value of the crossing generally. The possible accident effect as mentioned in paragraph 3.7.3.7 should also be taken into account.

Table 3.7.3.1
Criteria for Zebra Crossings in Rural Areas
Peak hour vehicular volume

<u>Number of Lanes</u>	<u>Without Pedestrian Refuge</u>	<u>With Pedestrian Refuge</u>	<u>Peak Hour Pedestrian Volume</u>
2 lanes	1000	-	70
3 lanes	600	-	70
4 or more lanes	400	1000	70

- 3.7.3.7 Accident statistics may also be taken into account when considering the introduction of a zebra crossing or the change of a zebra crossing to another form of crossing. If detailed analysis of the accident pattern indicates that inadequate pedestrian crossing facilities is one of the contributory factors of the accidents, then these may be used to justify the need for a crossing, or a change of crossing type even though the conditions in paragraph 3.7.3.5 may not be entirely satisfied. However, research findings in “The Overall Effect on Accidents at Sites where Zebra Crossings were Installed” of the U.K. have indicated that, "the installation of a zebra crossing can achieve a significant reductions in accidents only if the accident rate, prior to installation, is at or above the average. In fact there is a danger that the installation will have a serious effect, particularly on pedestrians, if there is no definable problem before the crossing is installed." Territory conditions are not always the same as those in the U.K. but it would seem worth taking these findings into consideration when deciding the merits or otherwise of installing a zebra crossing.
- 3.7.3.8 Where vehicular flows averaged over the 6 hours exceed 1,000 vehicles per hour, other forms of crossings i.e. light controlled or grade separated may be more appropriate particularly in terms of safety and causing less disruption.
- 3.7.3.9 For existing zebra crossings where peak hour flows are equal to or exceed 1,700 vehicles per hour. consideration should be given to changing the crossing to a light controlled one, or where appropriate to a grade separated crossing.
- 3.7.3.10 Appropriate widths for zebra crossings are indicated in Table 3.7.2.1.
- 3.7.3.11 Desirable Minimum sight distances in accordance with Table 3.7.3.2 should normally be available to motorists on the approach to a zebra crossing, and should only in exceptional circumstances be less than the Absolute Minimum. Appropriate warning signs should be erected where visibility distances, are at or below Absolute Minimum.

Table 3.7.3.2
Sight Distance for Zebra Crossing

<u>Speed Limit (km/h)</u>	<u>Desirable Minimum(m)</u>	<u>Absolute Minimum(m)</u>
50	70	50
60	95	70
70	125	95

- 3.7.3.12 The location of zebra crossing as with other crossings should take account of advice given in section 3.7.1. However particular care should be taken where zebra crossings are located near bus stops that stopped buses will not obscure the vision of pedestrians or motorists. Zebra crossings should also be avoided near points where traffic streams merge as the motorists will have difficulty in observing both the traffic to be merged with, and possible pedestrians on the zebra crossing ahead. At exits From roundabouts particular problems arise where if the crossing is sited too close to the roundabout vehicles may tail back onto the roundabout, but if it is located too far away pedestrians may not use it. Each situation will require individual consideration but generally the crossing should not be located closer than 20m to the roundabout exit.
- 3.7.3.13 Zebra crossings impose a number of restrictions on vehicles, which are mentioned in more detail in Volume 3, and it is important that the implications of these restrictions are taken into account when proposing the installation of any zebra crossings. A particular point to bear in mind is the stopping restrictions imposed by the Zebra Controlled area and what if any implications this may have on frontage developments.

3.7.4 Signal Light Controlled Crossings

- 3.7.4.1 A typical layout of a signal light controlled crossing is shown in Diagram 3.7.4.1.

- 3.7.4.2 A signal light controlled crossing is more appropriate than a zebra crossing in the following situations:
- (i) where there are significant numbers of elderly and disabled pedestrians;
 - (ii) where pedestrian and/or vehicle flows are heavy;
 - (iii) at sites with relatively high approaching speeds;
 - (iv) at special sites such as contra-flow bus lanes; and
 - (v) in areas operating under an Area Traffic Control System.
- 3.7.4.3 The use of staggered crossing should be avoided and CTEs should personally vet and approve such installations, if absolutely necessary. If such type of crossing is provided, the staggering should preferably be left-handed so that pedestrians stepping onto the central reserve or refuge turn towards the approaching traffic to give them a better view of it. The central refuge should be large enough to accommodate the expected numbers of pedestrians gathered during each signal cycle.
- 3.7.4.4 The pedestrian signal aspects must be so positioned that pedestrians looking at these are also facing the approaching traffic as shown in Diagram 3.7.4.1.
- 3.7.4.5 In the event that the crossing width is excessive, say more than 9 m, it is advisable to conduct a site inspection to ascertain whether the provision of two sets of pedestrian signals is required.
- 3.7.4.6 The method of calculating signal timings and similar details are contained in Volume 4 of this manual.
- 3.7.4.7 When the signal light controlled crossing forms part of a signal controlled junction, careful consideration should be given to the form and siting of the crossing. Split vehicle movements in front of pedestrian crossing should be avoided as far as possible as this will mislead pedestrians who may be tempted to cross in front of stopped vehicles. If split phases have to be provided, channelising islands should be constructed in order to provide refuges for pedestrians to wait. If refuges cannot be provided in these circumstances it is preferable that the crossing point be relocated.
- 3.7.4.8 At signal controlled junction with light controlled crossings, vehicle/pedestrian conflict points should be checked in addition to checking the vehicle/vehicle conflict points to ensure adequate vehicle clearance time before commencement of the pedestrian green signal.
- 3.7.4.9 Predicted flows may be taken as the averaged four highest hours. Flows should be measured over a 50m length in the vicinity of the proposed location of the crossing, unless there is a crossing place already defined. However even with a defined crossing place it may be appropriate to extend the survey area to include pedestrians who may be crossing the road near but not on the crossing place.

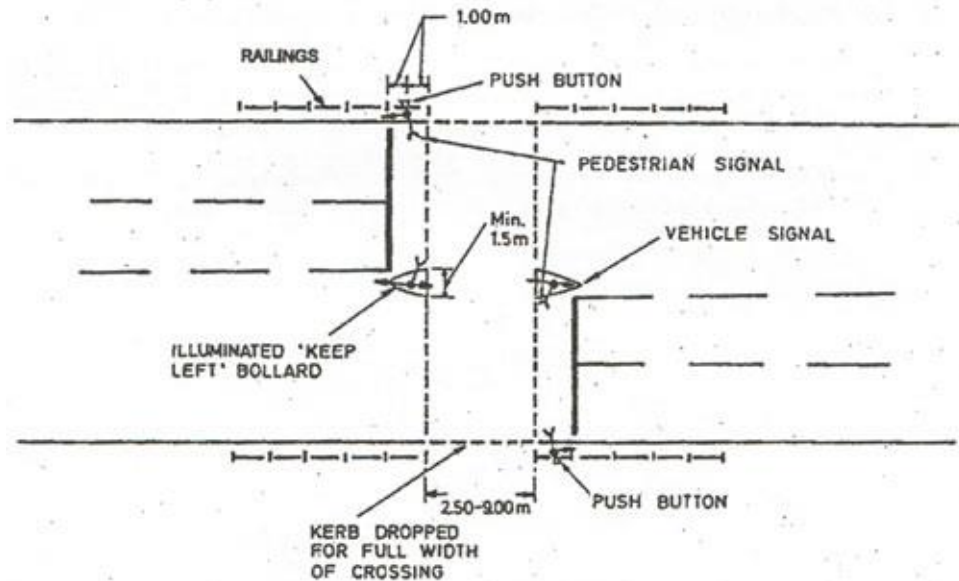
DIAGRAM 3.7.4.1 : TYPICAL SIGNALISED CROSSING LAYOUT

- 3.7.4.10 The location of the crossing point at signal controlled junctions with a pedestrian phase is important on the positioning of the dropped kerb. In many occasions kerbs have been dropped around the complete radius of the kerbs between the major and minor roads. Unfortunately this tends to encourage vehicles to negotiate the curve much closer to the kerb than they normally would. Therefore, the crossing should be aligned so that the tangent point of the radius on the minor road is the point where the kerb is first ramped down to form the dropped kerb. For large radius curves, however, this may mean that the crossing is located along the minor road footway away from the normal path of pedestrians and with insufficient reservoir width for pedestrians waiting to cross. In these latter instances the crossing may be positioned closer to the minor road, but the dropped kerbs should not extend along the circumferences of the kerb radius for more than half its length. However in many locations there is also an adjacent crossing on the major road and the adjustment of the crossing on the minor road can result in the dropped kerbs of both crossings coinciding. If the crossing on the major road cannot be set further back to avoid this, at least 2m and preferably 3m of raised kerbs should be provided between adjacent crossings.
- 3.7.4.11 As with other crossings it is essential that there is adequate reservoir space at the side of the road and within any refuge island provided for pedestrians to wait without encroaching onto the carriageway and without obstructing the movements of other passing pedestrians.
- 3.7.4.12 Audible traffic signals must be provided at signal light controlled crossings to assist visually impaired persons. For details of operation hours, refer to Volume 4 Chapter 4.
- 3.7.5 Cautionary Crossings at Signal Controlled Junctions**
- 3.7.5.1 These are crossing places indicated by studs and incorporated as part of a signal controlled junction installation, but have no separate pedestrian phase provided. Pedestrians have no right of way at these places but are encouraged to cross "with the light" during the red periods to vehicular traffic.
- 3.7.5.2 The use of this type of crossing should be avoided wherever possible and particularly where split phases and relatively high vehicular movements are involved.
- 3.7.5.3 The disadvantage of this type of crossing is that pedestrians are required to look at the signal heads intended for vehicular traffic to see when it is appropriate to cross. The most visible one to pedestrians is generally the secondary signal which means that pedestrians will be looking in the opposite direction to which traffic is approaching to their obvious disadvantage should the signals suddenly change.

3.7.5.4 Where this type of crossing is employed similar consideration to the siting of the crossing as that for signal light controlled crossings should be given.

3.7.5.5 Appropriate crossing widths may be determined from Table 3.7.2.1.

3.7.5.6 Only studs should be used to delineate the crossing area for these type of cautionary crossings, any other markings which may be used for signal light controlled crossings are not appropriate.

3.7.6 Uncontrolled Cautionary Crossings

3.7.6.1 These crossings are only intended to indicate the general path that pedestrians should follow when crossing a road.

3.7.6.2 Studs or other markings should not be used to delineate or enhance the area of the crossing. The only indications that it is a crossing point should be a dropped kerb and railings to be provided on both sides of the crossing, and if the carriageway is relatively wide, and subject to paragraph 3.7.6.6, a pedestrian refuge in the middle of the carriageway.

3.7.6.3 Cautionary crossings should generally only be provided across local or feeder roads, and their use should be avoided across dual carriageways wherever possible.

3.7.6.4 Similar considerations as that given to signal controlled crossings, will need to be given to the siting of the dropped kerbs where the cautionary crossing is adjacent to a junction.

3.7.6.5 Table 3.7.2.1 may be used to determine the appropriate width over which the kerbs should be dropped.

3.7.6.6 Refuges should not be provided unless at least a 3.8m, or 4.5m carriageway if the percentage of heavy goods vehicles and buses is high, can be provided on either side of the refuge.

3.7.6.7 Where a refuge is provided the nose of the island should be set back at least 3m from the edge of the carriageway of the major road as shown in Diagrams 3.4.7.1 and 3.4.7.2.

3.7.7 Grade Separated Crossings

3.7.7.1 Grade separated crossings consist of the following types:

- (i) Pedestrian footbridges
- (ii) Pedestrian/cycle bridges
- (iii) Pedestrian subways
- (iv) Pedestrian/cycle subways

3.7.7.2 Because of the potential danger to pedestrians crossing at grade and the disruption to traffic by at-grade crossing movements on congested roads, wherever justified consideration should be given to providing grade separated crossings in order to segregate pedestrians from vehicular traffic. The justifications for each case should be considered on its own merits, taking into account the following factors in the area concerned:

- (i) the anticipated pedestrian utilisation;
- (ii) the type, characteristics and layout of the road concerned;
- (iii) the volume and speed of the traffic;
- (iv) road safety and capacity considerations;
- (v) the desired pedestrian path;
- (vi) the availability and location of alternative crossings;
- (vii) the connectivity of the facility with nearby developments and walkway systems;
- (viii) capital and recurrent cost considerations; and
- (ix) public opinions.

3.7.7.3 The timing of providing grade separated facilities should tie in with the timing of adjacent developments as far as possible. If a grade separated facility could not be justified initially as part of new development, consideration may be given if appropriate to whether space should be reserved for later construction of such facility.

3.7.7.4 To ensure maximum effectiveness of the grade separated facilities, they should be located as close as possible to desired pedestrian paths, and their use does not involve detours or unnecessary climbing.

3.7.7.5 In developed and development areas, all footbridges, elevated walkways and subways, including approach steps and ramps, should have covers. However, covers need not be provided for ramps or bridges designed exclusively for bicycles. In other areas, the provision of covers depends on the circumstances at the particular location. Any proposal of exemption from providing cover requires the approval of Transport and Logistics Bureau. Application for permission of not providing covers shall contain appropriate justification, including background and reasons for the request, and an account of the extent and result of any consultation with the locals and the relevant District Office. Also, a recommendation on whether provisions for future installation of covers should be made when submitting the application for omission of covers to the Transport and Logistics Bureau.

3.7.7.6 Table 3.7.7.1 shows capacity flows for pedestrian bridges and subways. In front of display windows an allowance of 0.5m dead width should be subtracted from the clear width available, when calculating capacity figures.

Table 3.7.7.1
Capacities for Footbridges and Subways

<u>Section</u>	<u>Capacity Flow</u> (Ped / Metre / Min)
Level	50
Stairs or ramps	40

3.7.7.7 Table 3.7.7.2 sets out the design dimension standards for footways and subways and takes into account recommendations made to improve access for the disabled. For further information as to design details the Structures Design Manual for Highways and Railways should be referred to.

- 3.7.7.8 Some reduction in the widths of stairways may be appropriate where sites are physically restricted such as at tram islands, but care must be taken that there is sufficient space for pedestrians proceeding in opposite directions to pass one another without endangering themselves or others. The use of "absolute" maximum height risers should be avoided in these circumstances.
- 3.7.7.9 Where steps to footbridges incorporate a change in direction the minimum width of landing as given in Table 3.7.7.2 may not be adequate and should be checked against the capacity of the stairs. Also as far as possible a forward clear visibility of at least 3m should be maintained.
- 3.7.7.10 To minimise pedestrian fears for their safety in subways where possible corners should have a 4.6m radius in order that a minimum visibility distance of 4m is achieved. This is also relevant if the subway is a combined pedestrian/cycle way and in these cases a greater visibility distance is desirable, though it is accepted that the visibility distances for cycle tracks given in paragraph 3.8.3.11 may be difficult to attain. Similarly, consideration should be given to the design of footbridge railings or glass wall, so that pedestrians are visible from outside.
- 3.7.7.11 Access for people with disabilities should be provided for all footbridges, elevated walkways and subways either by the provision of ramps or lifts. Unless site conditions dictate one form over the other, provision of ramps and lifts should be treated on an equal basis. For new construction projects, the provision of both ramp and lift at the same time shall only be considered when high demands justify the provision of both facilities. To determine whether a ramp or a lift should be provided will involve the consideration of the following:
- (i) proximity of the facility to existing and future developments where lifts may be provided therein;
 - (ii) site constraints (such as underground utilities, land availability) and land use in the vicinity;
 - (iii) effect of ramps on adjacent properties and the environment (such as visual impact and impact on air ventilation);
 - (iv) the convenience of pedestrians and/or other road users;
 - (v) mitigating against the felling of roadside trees;
 - (vi) demands for lift facilities from organisations such as those for persons with disabilities or the elderly; and
 - (vii) feasibility of providing lifts/ramps.
- 3.7.7.12 Favourable consideration should be given to the provision of a lift if the following situations apply:
- (i) a ramp cannot be provided, e.g. due to site constraint;
 - (ii) a reasonable alternative to crossing the road in question is not available; or
 - (iii) there is demand for such facilities from organisations such as those for persons with disabilities or the elderly.

- 3.7.7.13 Where there are developments adjacent to a proposed footbridge, elevated walkway and/or subway, care should be taken during the planning process to enable the connection of the footbridge, elevated walkway and/or subway to the development with lifts/escalators being provided in the development. These facilities could replace the provision of ramps and lifts. However, the lease conditions and/or planning approval conditions must contain provisions to the effect that the developer has the responsibility to ensure 24 hours free access of such facilities to adjoining public footways. Connections between these facilities and the grade separated crossings should be barrier-free and are easily accessible by the public without unreasonable detour. The completion of the footbridge, elevated walkway and/or subway should tie in with the completion of the development. If for any reason the footbridge, elevated walkway and/or subway is constructed in advance of the development, temporary stairways and temporary at grade crossings for people with disabilities should be provided before the development is completed.
- 3.7.7.14 The size, capacity and number of lifts to be provided should be demand-driven and well justified. The project proponents should consider the existing and planned local demands in a holistic manner, such as:
- (i) close proximity to care centres, workshops, organisations, etc. for persons with disabilities or the elderly; and
 - (ii) demands from local residents such as the aged population and persons with disabilities.
- 3.7.7.15 Vertical clearance of footbridges should meet the requirement in Table 3.5.1.1. Except above tramways and railways, clearance greater than 5.5m should be avoided and only be accepted under special circumstances (e.g. footbridge connecting two buildings without direct ground access), as excessive height of stairs would affect walkability and discourage their usage, especially for elderly and disabled. If excessive height has to be introduced, the number and size of lifts to be provided should be critically reviewed, and stairs may be omitted in accordance with Table 3.7.7.2. It is important to make sure that the whole pedestrian route is barrier free, particularly when there is significant variation of footbridge level.
- 3.7.7.16 Project proponents are given the discretion on whether ramps or lifts should be provided in each case, as well as the size, capacity and number of lifts, with due consideration to the above paragraphs. If in doubt, the advice of the Transport and Logistics Bureau should be sought.
- 3.7.7.17 At some locations, physical barriers may be necessary to prevent vehicles from driving into subways or subway approaches.
- 3.7.7.18 The shared use of facilities by pedestrians and cyclists is not recommended, and cyclists wherever possible should be segregated from pedestrians preferably by level difference or guard railing as shown in Diagram 3.7.7.1. Where these measures are not suitable, a raised dividing line should be provided. Alternatively, cyclists should be made to dismount if a shared use has to be accepted.
- 3.7.7.19 The minimum dimensions for cross sections of combined pedestrian/cycle way is shown in Table 3.7.7.3.
- 3.7.7.20 Stopping sight distance for cyclists given in Table 3.7.7.4 within the subway and on the approaches should be provided as illustrated in Diagram 3.7.7.2. These distances are applicable to design speeds of 10 km/h or less on sharp curves and straights with staggered barriers, and 25 km/h or less on large radii and straights.
- 3.7.7.21 An unsegregated subway may be acceptable where the total number of pedestrians and cycles is small. The minimum dimensions for the cross sections are given in Table 3.7.7.3. The subway width may be reduced to 3.0 m if the total number of pedestrians and cycles is very small or where the space is restricted.

**DIAGRAM 3.7.7.1 : A CROSS SECTION OF
A TYPICAL SEGREGATED SUBWAY FOR COMBINED USE**

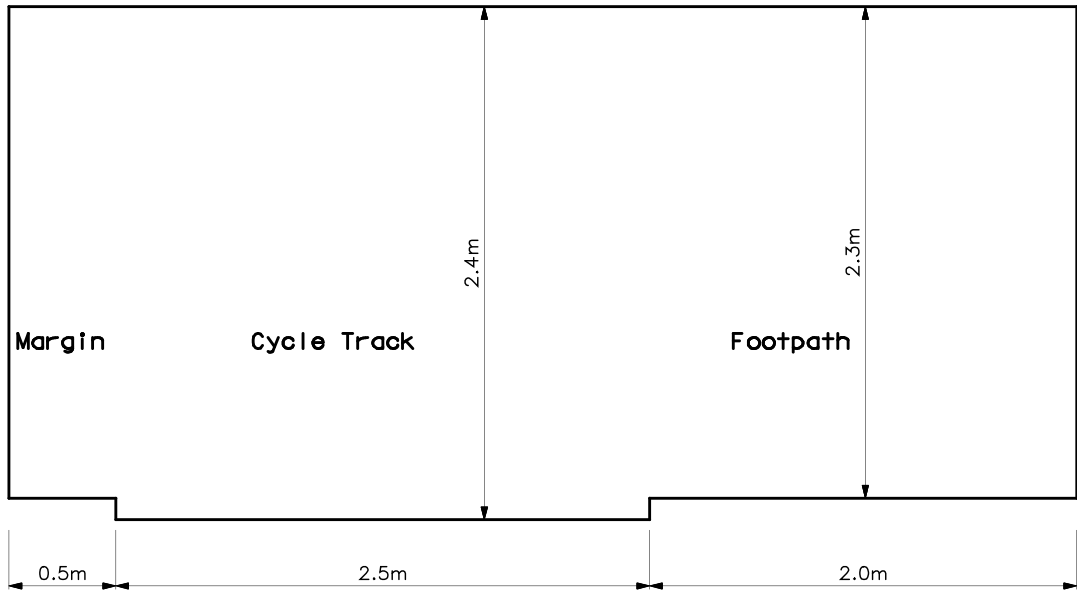
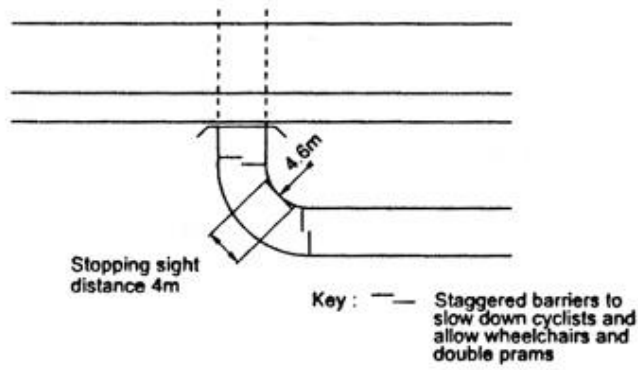

DIAGRAM 3.7.7.2 : STOPPING SIGHT DISTANCES FOR CYCLISTS

(i) Design speed ≤ 10 km/h



(ii) Design speed ≤ 25 km/h

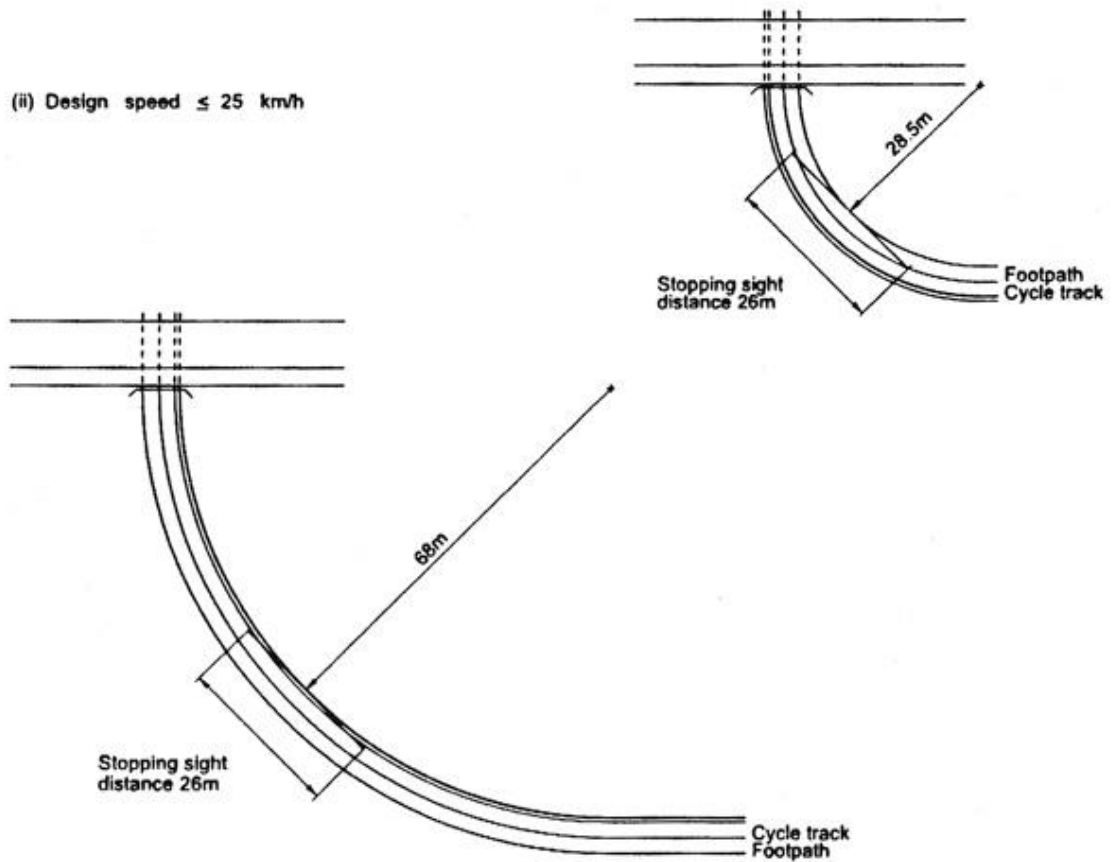

Table 3.7.7.2
Design Standards for Footbridges and Subways

		<u>Footbridges</u>	<u>Subways</u>
<u>Minimum effective width</u>	#	2m (except on stairs to Tram or similar platforms where a lesser width is necessary because of limited space)	3m
<u>Minimum vertical clearance</u>	#	Please see Table 3.5.1.1 of Volume 2 Chapter 3 of the Transport Planning and Design Manual	Please see Table 3.5.1.1 of Volume 2 Chapter 3 of the Transport Planning and Design Manual
<u>Ramps / Lifts</u>		<p>Where feasible stairs and either ramps or lifts should be provided on all approaches. If site conditions do not permit, either ramp or lift should be provided. Provision of ramps and lifts should be treated on an equal basis.</p> <p>Desirable maximum gradient = 1 in 12 Absolute maximum gradient = 1 in 10 Centre line of circular ramps should never exceed 10% Stepped ramps should not be provided</p> <p>Adequate reservoir space / waiting space must be provided near the lift entrance for lift users to wait without obstructing the movements of other passing pedestrians.</p>	
<u>Stairways</u>		<p>¹Desirable maximum height of risers = 150mm ¹Absolute maximum height of risers = 165mm (in exceptional circumstances only) ¹Desirable minimum width of tread = 280mm ¹Absolute minimum width of tread = 250mm</p> <p>Desirable maximum flight of steps = 12 risers Absolute maximum flight of steps = 16 risers</p> <p>¹Values chosen for riser height "R" and tread width "T" must satisfy both: $2R + T = 580 \text{ to } 600$ $T \times R = 42000 \text{ to } 45000$</p>	
<u>Landings</u>	*	<p>Ramps steeper than 10% should have landings at vertical intervals not greater than 3,500mm. Ramps of 10% or less should have landings at vertical intervals not greater than 3,500mm where space permits. Desirable length for stairs= 1,500mm – 1,800mm Absolute minimum length for stairs= 1,000mm Desirable length for ramps= 2,000mm Absolute minimum length for ramps= 1,500mm</p>	
		Width of all landings = Not less than that of the approach stairs or ramps	
<u>Handrails</u>		Handrails must be provided on both sides of all ramps and stairways, and consideration should be given to the provision of central handrails on stairways 4000mm wide or more.	

*Ramps with gradients above 10% require approval from the respective AC for T/Region.

#Adequate allowance should be made for railings/handrails, lightings, finishes, etc. in calculating the clear width and height of footbridges/subways.

Table 3.7.7.3
Minimum Dimensions for Segregated and Unsegregated
Subways for Pedestrians and Cyclists

		Segregated		Unsegregated	
		< 23	≥ 23	< 23	≥ 23
Subway length (m)		< 23	≥ 23	< 23	≥ 23
Height (m)	Cycle track	2.5	2.7	2.5	2.7
	Footway	2.3	2.6		
Width (m)	Margin between subway wall and cycle track	0.5		4.0	
	Cycle track	2.5			
	Footway	2.0			

Table 3.7.7.4
Stopping Sight Distance for Cyclists

Designed speed	Minimum stopping distance (m)	Minimum radius of curvature of walls adjacent to cycle track (m)	Minimum radius of curvature of walls adjacent to footway (m)
≤10	4.0	4.6	4.6
≤25	26.0	68.0	28.5

3.7.8 Escalators at Footbridges and Elevated Walkways

3.7.8.1 The criteria for provision of escalators at footbridges and elevated walkways are:

- (i) when both stairs and ramps/lifts are provided, escalators should only be considered if the estimated number of pedestrians using the footbridge in both directions is at least 3,000 pedestrians per hour for at least one hour on a weekday;
- (ii) when stairs alone are provided, escalators should be considered where the average of the estimated three highest hourly flows in both directions on a typical weekday exceeds 1,500 pedestrians per hour; and
- (iii) both up and down escalators should be provided at footbridges and elevated walkways fulfilling these criteria.

3.7.8.2 The above criteria only apply in developed and development area, and should be applied with flexibility. Escalators will not normally be considered in other areas. A decision on whether to include escalators should also take account of other factors such as:

- (i) increasing the attractiveness to users of the facility in question in order to discourage pedestrians from crossing roads at-grade, and in particular from jay-walking, thereby reducing the danger of accidents;
- (ii) the availability of facilities, e.g. lifts and escalators, in both buildings connected to the footbridge or elevated walkway; and
- (iii) site constraints which inhibit the provision of ramps.

3.7.8.3 The following information on the escalator is useful:

- (i) In ascent, escalator have about twice the carrying capacity of steps.
- (ii) Escalators should not normally be provided without an alternative means of ascent or descent, whatever the case may be, as during times of maintenance to the escalators the footbridge will be inoperable.
- (iii) Operating capacities range between 112 persons/minute to 150 persons/minute.
- (iv) Speeds of escalators range between 0.5m/s to 0.75m/s, 0.6m/s is about 130 persons per metre width per minute.
- (v) Escalators in the territory generally have an angle of inclination of 30 degrees.
- (vi) Widths of escalators can vary considerably, depending on the location, aesthetics, and other similar matters. However escalators for footbridges should not generally have an effective width less than 1m if pedestrians are to be allowed to pass one another.

3.7.8.4 For descending escalators, care should be taken that there is sufficient reservoir space at the foot of the escalator. Preferably descending escalators should not discharge pedestrians onto the footway directly in line with an adjacent carriageway which they then may be required to cross at grade. Waiting pedestrians can impede the flow of pedestrians being discharged from the escalator, or those pedestrians being discharged may because of their momentum attempt to cross without paying sufficient attention to approaching vehicular traffic.

3.8 Cycle Tracks

3.8.1 General

- 3.8.1.1 The sharing of facilities by cyclists and other road users unless volumes are low is generally not a satisfactory arrangement because of the interference with the general flow of traffic and the vulnerability of cyclists. Therefore where cycle traffic is relatively large, additional or segregated facilities for cyclists should be provided.
- 3.8.1.2 The decision as to whether such facilities should take the form of cycle tracks parallel to existing or proposed carriageways, or cycle paths entirely separate from other vehicle routes will be dependent upon, the overall system being planned for, the land that can be made available, and the convenience of the route to cyclists. Inconvenient routes however well constructed will not be used by cyclists if there is a more direct route to their destination.
- 3.8.1.3 When considering the provision of cycle routes interested cycling organisations if possible should be consulted so that their opinions on the proposal can be obtained because their views as to the usefulness or otherwise of the route will be helpful.
- 3.8.1.4 *The Road Traffic (Traffic Control) Regulations* does not prevent, unless appropriate signs indicate otherwise, cyclists from using bus lanes, and it may therefore be appropriate when planning cycle routes to take advantage of any bus lanes provided in the area. However caution should be exercised, as the level of flow at which cyclists and buses can mix without buses being impeded or cyclists put at risk is not very high. Contra-flow bus lanes can present particular difficulties and danger to cyclists and sharing of these facilities should generally not be encouraged.
- 3.8.1.5 Cycle lanes, forming part of the carriageway and exclusively for cyclists, are not specifically provided for under the *Road Traffic (Traffic Control) Regulations*. In any event past experience and general traffic conditions would not indicate that such schemes would be suitable at the present time.

3.8.2 Provision of Cycle Tracks

- 3.8.2.1 The decision to provide separate facilities for cycles will generally be based on accident records and levels of existing or predicted cycle flows. However other arguments not necessarily having any factual support may also be used to influence the decision on the provision of cycle facilities. In these latter cases care should be taken that in agreeing to such facilities, a reasonable level of cycling activity can be guaranteed and that an overprovision of facilities is not made. Cycle tracks provided but not used to any extent will quickly deteriorate and may be occupied by undesirable activities. Such under-utilisation can also prejudice any future provision of cycle facilities.
- 3.8.2.2 Cycling in the Territory at the present time is mainly recreational, although in the New Territories some work journeys are made by cycle. However evidence on such journeys that are made is sparse and therefore it is difficult to provide warrants for cycle tracks based on local experience. As for the new development areas (NDAs) or new towns under planning, it is the Government's prevailing policy to promote a "bicycle-friendly environment" with a view to reducing the use of mechanized transport mode for short-distance commuting and promoting cycling as a recreational activity with health benefit, hence new cycle tracks as provided in the NDAs and new towns under planning should form a coherent network linking up trip origins and key destinations and they should be safe, direct, comfortable and attractive.

- 3.8.2.3 Table 3.8.2.1 gives guidelines as to when to provide cycle facilities based on information from abroad Recommended Practice for the Design and Layout of Cycle tracks. However it is suggested that these figures be used with caution, as given the very dense traffic conditions in urban areas in the Territory it is quite likely on safety grounds that segregated facilities for cyclists could be justified for much lower flows.

Table 3.8.2.1
Guidelines for the Provision of Cycle Facilities

	<u>Rural Areas</u>	<u>Urban Areas</u>	<u>Facility</u>
Cycle flows per 16 hr day	750	1000	Inside lane of carriageway widened to 4.5m
	1000	1500	Provide separate cycle track

3.8.3 Design of Cycle Tracks

- 3.8.3.1 Table 3.8.3.1 shows appropriate minimum widths to be used for cycle tracks. For cycle tracks to be provided in NDAs or new towns under planning, the design of cycle track width and their geometrical configurations should be based on the projected cycle flow forecasts under different commuting and recreational scenarios together with traffic safety considerations. The project proponents should make use of the latest and most appropriate planning data for conducting these cycle flow forecasts. If such information is not immediate available, then an assumption of cycling mode share of 3% to 5% of the total mechanised trips on a weekday in the NDAs or new town under planning may be adopted as an alternative subject to an approval by the relevant authority. In addition, the cycle track width may be flexibly increased where practical to accommodate any site specific considerations.

Table 3.8.3.1
Cycle Track Widths

	<u>Desirable(m)</u>	<u>Minimum(m)</u>
One way	2.8	2
Two way	4.0	3.5

- 3.8.3.2 Whilst 2m should be regarded normally as the minimum width for a one way cycle track, in other countries much narrower tracks have been used. Therefore in considering whether a cycle track should be provided or not, it may be preferable to provide a substandard width than none at all. Normally such widths should not be less than 1.5m for a one way track as even with this overtaking may be difficult and lead to encroachment onto adjacent footways or verges.
- 3.8.3.3 Figures on capacities for cycle tracks vary considerably, however a reasonable guide for most situations would be 500 cycles per metre width per hour for one way operations and 400 cycles per metre width per hour for two way operations.
- 3.8.3.4 Cycle tracks should be separated from any adjacent carriageway by a verge of at least 1.8m in width. In difficult situations, other than for Trunk Roads this width may be reduced to not less than 1m to allow reasonable clearances from any street furniture.
- 3.8.3.5 Gradients for cycle tracks will generally be dictated by the surrounding topography, however wherever possible these should not be excessive as this may distract from cyclists using the route.

- 3.8.3.6 Long gradients over 5% will cause cyclists to dismount, and therefore as a general guide, maximum gradients of 3% to 4% should be the aim. Where the cycle track follows the main carriageway route, the gradient will be dictated by this and no special attempt should be made to provide lesser gradients, however where excessive long gradients could result consideration should be given as to the actual usefulness of providing the cycle track or whether a more convenient route might be available elsewhere.
- 3.8.3.7 At subways and footbridges the desirable and normal maximum gradients are 4% and 8% respectively. In exceptional circumstances gradients of up to 10% may be acceptable with the approval of the respective AC for T/Region. For combined cycle/pedestrian ramps, the flatter ramps will often not be appropriate because of the greater pedestrian walking distances involved. Consideration should always be given to requiring cyclists to dismount at subways and bridges, particularly those which are shared with pedestrians.
- 3.8.3.8 Horizontal radii should preferably be not less than 5m, but in difficult conditions radii of 2m may be acceptable. Sharp reverse curves should be avoided.
- 3.8.3.9 Normally when a cycle track follows a main carriageway route any footway will be positioned at the rear of the verge/cycle track/footway area. However if there are bus stops along the route arrangements will need to be made to enable pedestrians to wait adjacent to the carriageway. Such waiting areas must be sufficiently wide to avoid pedestrians encroaching onto the cycle track or the adjacent carriageway. Points at which pedestrians are required to cross the cycle track in the vicinity of bus stops should be properly defined, with railings being used to prevent them crossing elsewhere. Appropriate signs and markings for these situations are shown in Volume 3. Where cycle and pedestrian traffic in these areas is heavy it may be safer to terminate the cycle track and instruct cyclists to dismount.
- 3.8.3.10 At main road junctions where there are joint pedestrian and cycle crossing facilities it is preferable that cycle tracks be terminated prior to the junction and cyclists be instructed to dismount with proper "Dismount" sign. This is particularly relevant where pedestrian and cycle flows are high. Pedestrians should never be put in a position where they may be trapped on the carriageway after having crossed the road because of the volume of cycles. Adequate reservoir space for waiting pedestrians and cyclists must be provided. Any refuge islands must be at least 2m wide in order that a cyclist can wait without the cycle protruding onto the carriageway.
- 3.8.3.11 Cyclists on cycle tracks should have a clear view ahead for a distance of preferably 25m but never less than 15m. Adequate sight lines must be provided for both pedestrians and cyclists where these are likely to intersect and in some instances railings may be necessary to prevent pedestrians stepping into the paths of cyclists when emerging from a side path or at the foot of steps. Care should be taken in the vicinity of pedestrian/cycle crossing points that street furniture, including any trees, does not interfere with the sight lines of pedestrians or cyclists.
- 3.8.3.12 Horizontal and vertical clearances should be in accordance with section 3.5.
- 3.8.3.13 An integral part of the design of a cycle track, is the quality of the finish, see "Providing for the Cyclist". Good surface regularity should be obtained and the materials chosen should provide a surface texture capable of obtaining a resistance to skidding in wet weather. It is also of advantage if the surface of the cycle track can be of a different colour to that of any adjacent footway. Adequate drainage must also be provided. Where a cycle track crosses a carriageway it should do so at right angles to the kerb, which should be dropped across the cycle track with an upstand not greater than 25mm.

3.8.3.14 In addition to the colour of the cycle track there should be a distinctive separation between the cycle track and any adjacent footway. This may be achieved by a continuous white line marking not less than 150mm wide, or preferably by kerbs with the cycle track at a level difference of at least 50mm to the footway. The latter method may however complicate drainage details, but is preferable as it reduces the chances of cyclists encroaching onto the footway.

3.8.3.15 Cycle tracks should be provided with a reasonable standard of illumination with particular care be taken at the junction of cycle tracks with other traffic routes.

3.8.4 Signs and Markings for Cycle Tracks

3.8.4.1 Appropriate traffic signs and markings for cycle tracks are shown in Volume 3.

3.8.4.2 To encourage the use of cycle routes, adequate direction signing should be provided, and in this respect it may be necessary to incorporate in main road signing the direction to cycle routes where this is not obvious. At the start of a cycle route, signs should indicate major destinations along and at the termination of the route. At intersections of routes, appropriate direction signing should also be provided. Where a cycle track is parallel to the carriageway additional direction signing would not normally be necessary as the main road signs should be sufficient for this purpose.

3.9 Railings, Barrier Fences and Crash Cushions

3.9.1 General

- 3.9.1.1 The provision of a particular barrier fence along a road depends on many factors such as pedestrian and traffic flow, road geometry, historic accident data, surrounding environment and sometimes, consideration has to be given on aesthetic side. The Transport Department, Fire Services Department, Hong Kong Police Force, Highways Department and other concerned parties as appropriate should be consulted before a barrier fence is to be erected or replaced on public roads.
- 3.9.1.2 Reference should be made to the Highways Department Standard Drawings for the detailed information of barrier fences and railings that are commonly used on public roads. As for vehicular parapets and pedestrian parapets on highway structures, Structures Design Manual for Highways and Railways should be referred.

3.9.2 Railings

- 3.9.2.1 Railings are not designed to protect pedestrians from vehicular impact but to control and guide pedestrians for road safety and traffic management purposes. The principles for the provision and design of pedestrian railings are stipulated in the TD/HyD Joint Departmental Circular (TD DC No. 3/2017 or HyD TC No. 2/2017) and TD Departmental Circular (TD DC No. 2/2020).
- 3.9.2.2 To avoid overuse of railings which could cause public inconvenience and adverse effects on streetscape and footway capacity, alternative measures such as footway improvement, provision of planters or bollards should be considered.
- 3.9.2.3 However, railings can be considered at locations with high risk of pedestrian and vehicle collision if alternative measures are not feasible nor applicable. Examples are:
- (i) Accident records indicate that it is an accident prone site involving pedestrians;
 - (ii) Pedestrians tend to walk on carriageway with high traffic speed; or
 - (iii) Visibility of pedestrians or drivers is restricted, for example, due to sharp bends or illegally parked vehicles.
- 3.9.2.4 Pedestrian railings should not be provided merely to deter illegal parking and at locations where other physical barriers such as planters or raised central medians already exist.

- 3.9.2.5 Table 3.9.2.1 categorizes various types of railings by purpose and intended use. The design and colour of railings should be compatible with the neighbouring streetscape. As the paint would require regular maintenance and incur additional recurrent cost, agreement with the maintenance party should be sought if colouring of railings is proposed.

Table 3.9.2.1
Purpose and Intended Use of Various Types of Railings

Purpose	Use	Choice of Railing
Control	Examples of controlling pedestrian movements: a) on footways where pedestrian flow exceeds footway capacity; b) at central islands of staggered crossings; and c) at central medians to prevent jay walking.	HyD Standard Drawings – control category
Guidance	Examples of guiding pedestrians: a) near pedestrian/grade-separated crossings; and b) on footways where there is expected surge in pedestrian flow at times.	HyD Standard Drawings – guidance category

- 3.9.2.6 TD and HyD should be consulted on customized design. Any newly designed railing should be approved by TD and HyD.
- 3.9.2.7 Type 2 or other suitable type of railings under control category to prevent pedestrians from falling from height should always be provided where the footway is higher than adjacent carriageway, verge or other area by 1500 mm or more, or there is a steep downhill slope at the back of the footway.
- 3.9.2.8 Railings of guidance category should be provided to prevent pedestrians spilling onto the carriageway opposite exits to cinemas, theatres, schools, or to other places where similar sudden large pedestrian flows might be expected. In particular, near kindergarten exits, railings of control category should be provided and extended to a safe crossing or roadside pick-up point. In case the existing footpath width fronting the exits is less than 2m, railings shall still be provided but footpath widening should be explored to accommodate the expected surge of pedestrian flow. Local build-out should also be considered if footpath widening is not feasible. Further, if large flow of small children is anticipated, railing types which would not affect visibility nor allow small children passing through easily should be adopted.
- 3.9.2.9 When pedestrian flows are in the vicinity of or exceed the capacity flows given in Table 3.4.11.1, railings of control category should generally be erected to prevent pedestrians from walking onto the carriageway. However, where these conditions occur on footways less than 2m in width, discretion will be necessary, as the installation of railings might make conditions worse because of the reduction of effective footway width (see also paragraph 3.9.2.19).
- 3.9.2.10 In the immediate vicinity and on either side of at-grade crossing points, railings of guidance category should be erected to channel pedestrians to the crossing points and to discourage jay walking. The exact length of the railings required will depend upon individual site conditions, but normally the lengths should be limited to 6m on either side (see also paragraph 3.9.2.14).

- 3.9.2.11 In the vicinity of grade-separated crossings, generally, railings of guidance category will need to be erected along the footway to encourage the use of such facilities. If jay walking is likely to be serious, railings of control category should be used. The required length of railing will depend upon circumstances prevailing, but should be kept to the minimum, for example, the minimum sufficient railing in the vicinity of the entrance/exit will be needed to prevent pedestrians from encroaching onto the carriageway.
- 3.9.2.12 For dual carriageway along District or Local Distributor Roads without planters or raised median at the central reserve, railings of control category could be considered to be provided along the central reserve to prevent pedestrians from crossing the roads other than at designated crossing points, if similar railings are not provided on both sides of the carriageway.
- 3.9.2.13 In respect of the above paragraphs it is relevant to note that Regulation 39 of the *Road Traffic (Traffic Control) Regulations* prohibits pedestrians from :
- (i) Crossing within a zebra controlled area other than on a zebra crossing;
 - (ii) Crossing within 15m of a light signal crossing otherwise than at the crossing where such lights operate;
 - (iii) Crossing within 15m of a footbridge or subway or any part of it otherwise than by means of the footbridge or subway; and
 - (iv) Climbing over or through any kerbside fence or central reserve onto a carriageway.
- The careful use and choice of railing type on a need basis will assist in the enforcement of this regulation.
- 3.9.2.14 Railings of control category are required to contain and channel pedestrians at central traffic island of staggered crossings. With the provision of railings, it must be ensured that there should still be sufficient room on the island for pedestrians to wait.
- 3.9.2.15 Where illegal parking of vehicles on footways causes road safety or traffic problem but control of pedestrian movements is not a problem, erection of suitable bollards may be considered if police enforcement and other alternative engineering means are found to be ineffective. The spacing between bollards may be varied according to prevailing circumstances and may be as much as 2.5m for footways at which the width is not greater than 2m, or 2m where the footway is greater than 2m in width. The wider spacing should be employed where servicing of frontage developments or the setting down or picking up of passengers is frequent. Care should be taken to avoid excessive use of bollards as it would cause inconvenience and unnecessary hazard to pedestrians, particularly those with disabilities or visual impairment.
- 3.9.2.16 At crossing points, road junctions or similar locations, it is necessary to use railings that would not impair visibility of motorists and pedestrians. For example, "Type 2 Railings at Junctions and Crossings" may be considered. For similar reason, roadside advertisements, banners and any other objects that will obstruct the visibility of motorists and pedestrians should be prohibited from being hung on the traffic upstream side of the crossing points or road junctions for a length of about 30m.
- 3.9.2.17 In prestige areas dwarf walls may be used instead of railings and these are particularly applicable where planting of verges and central reservations on District or Local Distributor Roads is considered appropriate.
- 3.9.2.18 Railings or dwarf walls should not be used in the vicinity of carriageways of Trunk Roads or Primary Distributors for which barrier fences should be used.

3.9.2.19 Horizontal clearances of railings from the edge of carriageway should generally be in accordance with Table 3.5.2.1 but in circumstances where this would reduce effective footway width to below 1.5m the minimum clearance may be reduced to 200mm.

3.9.2.20 Guidelines on the design of railings are at the Annex. For pedestrian railings or parapets to be used on pedestrian footbridges and subways, reference should be made to the Structures Design Manual for Highways and Railways.

3.9.3 Barrier Fences

3.9.3.1 Safety barrier fences and vehicular parapets are intended to prevent vehicles leaving the carriageway and keep any damages and injuries to the vehicles and their occupants to a minimum. The approved types for use in the Territory are untensioned corrugated beam barrier fences, concrete profile barrier fences, high containment concrete barrier and vehicular parapets. Apart from vehicular parapets which are shown in Structures Design Manual for Highways and Railways, the approved barrier fences are shown in Diagram 3.9.3.1 and for further details, refer to Highways Department Standard Drawings. Under circumstances when the design of a barrier has to deviate from the approved types, the project proponent has to design the barrier to attain the appropriate containment level commensurate with the guidance in this chapter. Explicit agreement from the Highways Department is required for design of barrier fences deviated from the approved types.

3.9.3.2 Barrier fences will generally only be used on Trunk Roads, Primary Distributors and Rural Roads in circumstances when it is considered that more danger will be occasioned to the vehicle and its occupants in leaving the carriageway than if it is constrained by barrier fences. To accomplish this goal, the barrier fences need to be long enough to shield the hazard, be strong enough to contain the vehicle, and be designed to allow for smooth redirection of vehicle with tolerable deceleration. Where both barrier fences and railings are provided alongside with each other, the clearance between them should not exceed 250 mm to prevent children passing through the gap.

3.9.3.3 It is important that the required horizontal clearances as set down in Table 3.5.2.1 are achieved. In cases where a hard shoulder or marginal strip in accordance with sections 3.4.7, 3.4.9 and 3.4.12 is provided this will generally be automatically achieved, but elsewhere the barrier fences may have to be set back. Where concrete profile barriers replace existing fences, or central reservation railings, the minimum clearance between the foot of the barriers and the edge of carriageway may be reduced to 300mm. Where this reduced clearance is adopted, care should be taken that the clearance to other street furniture such as lighting columns, gantry legs, traffic signs etc. does conform to Table 3.5.2.1.

3.9.3.4 It should be noted that concrete profile barrier fences should not normally be installed without an accompanying marginal strip constructed to the same standard as the carriageway and incorporating a continuous edge line marking in accordance with Volume 3. Normally the marginal strip will be formed from the available verge or central reserve width, but where this cannot be achieved the carriageway itself should be used and the lane widths reduced accordingly. The edge line marking is important in clearly defining the edge of carriageway particularly at night as concrete profile barriers are not always clearly discernible. The marginal strip provides the necessary minimum clearance from the carriageway and gives the motorists a further chance of avoiding the barrier should he momentarily lose control.

3.9.3.5 Terminal sections including those at emergency crossings not installed with Movable Steel Barrier must be ramped down or provide crash cushions as appropriate to avoid more serious injury occurring to occupants of impacting vehicles. Details of the ramp down are given in the Highways Department Standard Drawings.

Containment Levels

- 3.9.3.6 The range of possible vehicular impacts onto a barrier is extremely large in terms of vehicle type, approach angle, speed and other road conditions. For standardization, the performance of a barrier is defined in terms of its containment level based on standardized impact configuration. The configuration factors mainly involve the vehicle type, mass, impact speed and impact angle. A barrier claimed to attain a specific level of containment shall be able to contain the impact vehicle and return severity indices not inferior than those stipulated in BS EN 1317 when tested under each and every of the impact configurations of the corresponding containment level.
- 3.9.3.7 With reference to overseas standards and the Structures Design Manual for Highways and Railways published by the Highways Department, four containment groups are formed and shown in Table 3.9.3.1 below. The corresponding vehicle characteristics are given in Table 3.9.3.2. Products from overseas are treated as equivalent if they are attested to the same level of protection required in this guidance.

Table 3.9.3.1
Roadside Barrier Containment Levels

Level of Containment	Vehicle type	Vehicle mass (tonne)	Impact speed (km/h)	Impact angle (degrees)	Equivalent Overseas Standards
L1	Passenger car	1.5	80	20	TL2 (MASH* or NCHRP# Report 350)
L2	Passenger car	1.5	113	20	TL3 (MASH or NCHRP Report 350)
L3	Passenger car	1.5	113	20	TL5 (MASH or NCHRP Report 350) or H2 (EN1317)
	Double-decked bus	22	50	20	
L4	Passenger car	1.5	113	20	L4a + L4b (EN1317)
	RHGV	30	65	20	
	AHGV	38	65	20	

Remarks

RHGV – Rigid Heavy Goods Vehicle

AHGV – Articulated Heavy Goods Vehicle

* MASH – AASHTO Manual for Assessing Safety Hardware

NCHRP – National Cooperative Highway Research Programme sponsored by AASHTO in cooperation with FHWA of the USA

Table 3.9.3.2
Vehicle Characteristics

Vehicle Specification	Type of Vehicle			
	1.5 tonne Passenger car	22 tonne Double-decked bus	30 tonne Rigid Heavy Goods Vehicle	38 tonne Articulated Heavy Goods Vehicle
<u>Mass (kg)</u> Total vehicle mass including dummy and ballast	1500 ± 75	22000 ± 500	30000 ± 900	38000 ± 1100
<u>Dimensions (m)</u> Wheel track (front to rear)	1.50	2.00	2.00	2.00
Wheel radius (unloaded)	N/A	0.55	0.55	0.55
Wheel base (between extreme axles)	N/A	6.80	6.70	11.25
Ground clearance of the front bumper measured at the corner	N/A	N/A	0.58	0.58
Number of axles (S = Steering Axle) (Note : Limit deviation ± 15%)	1S+1	1S+2	2S+2	1S+4
<u>Centre of gravity location (m)</u> Longitudinal distance from front axle (CGX) ±10%	1.24	4.40	4.10	6.20
Lateral distance from vehicle centre line	± 0.08	± 0.10	± 0.10	± 0.10
Height above ground (CGZ)	0.53 ± 0.05	1.75 ± 0.10	1.90 ± 0.10 (for load only)	1.90 ± 0.10 (for load only)

Untensioned Corrugated Beam - W-Beam

- 3.9.3.8 The untensioned corrugated beam safety fence is a L1 containment roadside barrier. There are two types of untensioned corrugated beam safety fences, i.e. with compacted earth footings and with concrete footings.
- 3.9.3.9 The safety fences with compacted earth footings are less rigid than those with concrete footings. They need considerable deflection space and are generally suitable only for wide central reservations.

DIAGRAM 3.9.3.1 : TYPICAL BARRIER FENCES

W-BEAM BARRIER (L1)

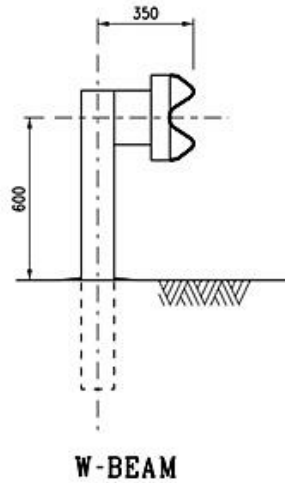

THRIEBEAM BARRIER (L2)

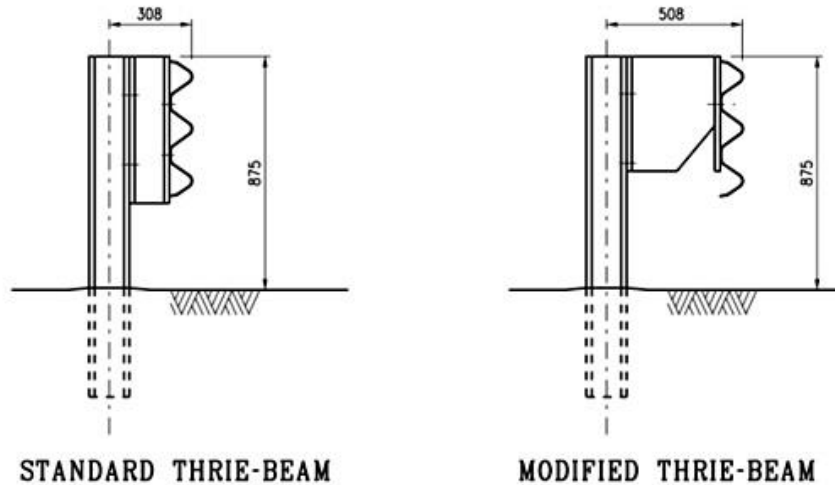

CONCRETE PROFILE BARRIER FENCE (L2)

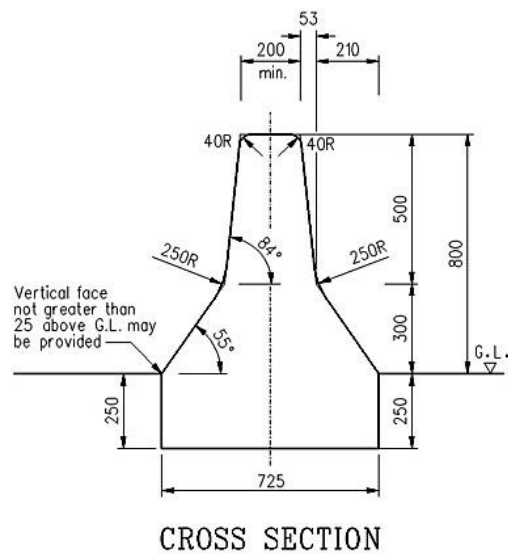

THRIE-BEAM BARRIER WITH ADDITIONAL RAIL (L3)

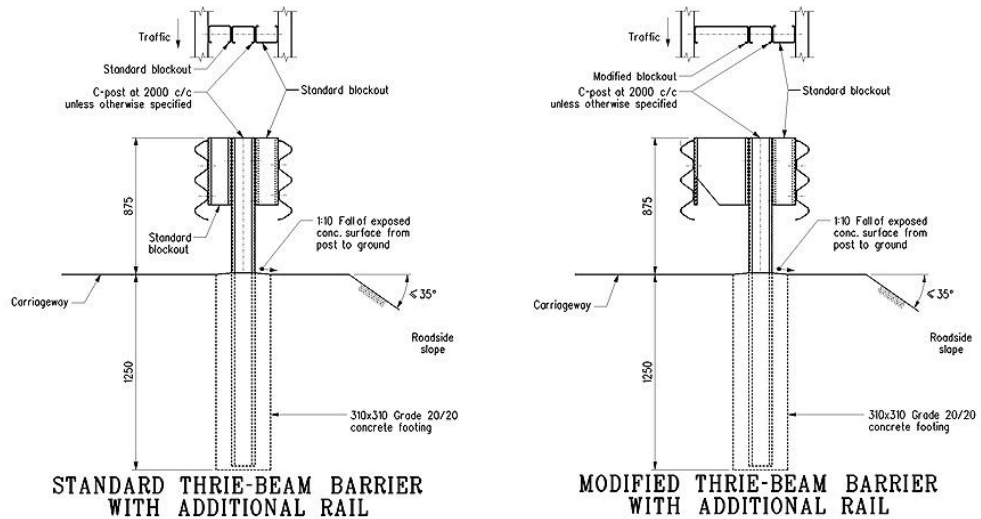

HIGH CONTAINMENT CONCRETE BARRIER (L4)

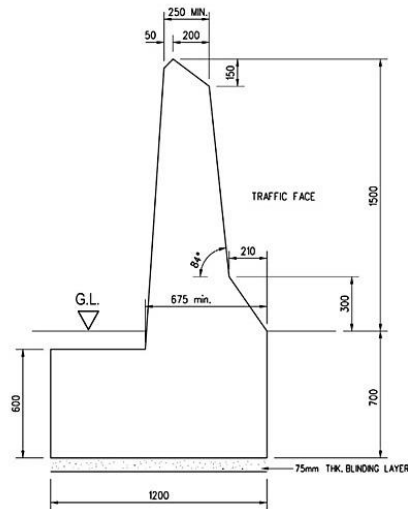

TYPICAL DETAILS OF L4 HIGH CONTAINMENT BARRIER

NOTE: ALL DIMENSIONS ARE IN MILLIMETRES

- 3.9.3.10 The other safety fence type with concrete footings, which should be fixed to concrete anchor blocks, can be used at locations where structures need to be protected and there is limited deflection space. The untensioned corrugated beam safety fence stated in the following paragraphs refers to the concrete footing type unless otherwise specified.
- 3.9.3.11 Posts of these safety fence types should normally be at 4m spacing. However, the spacing should be reduced to 2m if greater rigidity is required for protection of lighting columns and structures or where traffic accident black spot site is located.
- 3.9.3.12 The corrugated beam safety fence installed for the protection of lighting columns and structures should
- have posts spaced at 2m;
 - have sufficient clearance as suggested in Table 3.9.3.3 between the back of the post and the face of the structure being protected; and
 - extend at full height at least 10m in advance of the structure and at least 6m beyond it.

- 3.9.3.13 The beam should be ‘blocked out’ for a minimum of 200mm from the support post to enable an impinging vehicle to slide smoothly along the beam without being entrapped by the post and also helps to maintain the height of the beam when the posts are bent back on impact, thus preventing the vehicle from rolling over.
- 3.9.3.14 Where space is limited and blocking out pieces cannot be used, the beam may be attached directly to the post. Other alternatives such as road widening, reduction of speed limit and erection of appropriate warning sign should also be considered.
- 3.9.3.15 Safety fences are generally accepted to be more effective when kerbs are not present. However, if corrugated beam fence is installed intermittently only to protect structural columns or similar on roads other than Trunk Roads, kerbs may be provided with the safety fence positioned behind them.
- 3.9.3.16 The safety fence must be erected with its centre line at a height of 600mm measured from:
- (i) the surface of the adjoining carriageway, margin strip or hard shoulder if this is within 1500mm of the beam; and
 - (ii) the surface of the ground below the beam if the beam is more than 1500mm from the adjoining carriageway, margin strip or hard shoulder.
- 3.9.3.17 Beam sections should be lapped in the direction of traffic flow and its ends should be ramped down and flared away from the carriageway.
- 3.9.3.18 The traffic face of safety fence should be in line with and preferably connected to any bridge parapet with which it is contiguous.

Thriebeam

- 3.9.3.19 The thriebeam is a L2 containment roadside barrier. The standard thriebeam is similar to the untensioned corrugated beam but has three number of troughs (or crests) instead of two and is mounted higher. This is much stiffer than the conventional corrugated beam due to its stronger posts, beam rail and closer spacing of posts.
- 3.9.3.20 The standard thriebeam can reduce the incidence of rolling over in large vehicle collisions more effectively. This is accomplished by increasing the beam mounting height to 875mm and using a stronger blockout. It is therefore preferable to the untensioned corrugated beam when there is high frequency of traffic accidents involving vehicles of high centre of gravity.
- 3.9.3.21 In the event that the standard thriebeam is deemed less desirable because frequent impact by heavy vehicles is expected, the standard blockout for thriebeam shall be replaced by a 350mm deep modified blockout. Such blockout has a notch at the bottom which allows the lower portion of the beam and the flange of the spacer block to bend in during collision by vehicles of high centre of gravity, keeping the rail face nearly vertical and thereby retaining the vehicle from rolling over.
- 3.9.3.22 The use of standard/modified thriebeam can be considered where a higher rigidity of barrier fence than corrugated beam is required but concrete profile barrier is not warranted due to the associated cost, accident risk and space availability, etc. This type of barrier can more effectively reduce the incidence of rolling over by high vehicles when impacted.

Concrete Profile Barrier

- 3.9.3.23 The concrete profile barrier is a L2 containment roadside barrier. The theory of the concrete profile barrier is that when a vehicle strikes at an angle of 15° or less the impact energy is absorbed in compressing the suspension of the vehicle. The front wheels of the vehicle climb up the 55° slope and on contact with the upper slope the wheels are turned parallel to the barrier's longitudinal axis and the vehicle is redirected.
- 3.9.3.24 The concrete barrier will contain most vehicles within the carriageway, though at high angle, serious damage can result.
- 3.9.3.25 Concrete profile barriers require little maintenance, therefore they are ideal for locations where maintenance would cause considerable traffic disruption. However, because of the damage that can be caused to vehicles and their occupants by high angle impacts, the potential risk of this type of accident occurring, particularly on roads having a design speed or speed limit of 80 km/h or more, should also be taken into account when considering the use of this type of barrier fence.
- 3.9.3.26 Although the concrete profile barrier requires minimum space, it can have an inhibiting effect on motorists and therefore a parallel hard strip should be provided between the barrier and the edge of the carriageway. Where the hard strip is 1500mm or more the hard strip should be delineated by 200mm wide continuous white line, where it is less than 1500mm wide the hard strip should be delineated by 100mm wide continuous white line. The hard strip should not be less than 300mm wide, and preferably should be wider.
- 3.9.3.27 While planting is aesthetically pleasing on central reservations, care should be taken, particularly when used in conjunction with concrete profile barriers, that sight lines are not obscured either at the time of planting or by subsequent growth.
- 3.9.3.28 A ramp down concrete end treatment is used to terminate a concrete profile barrier in locations where speed limit is 50 km/h or less and space is limited. For speed limit greater than this, flare end treatment or crash cushion may be considered.

Thriebeam with Additional Rail / Modified Thriebeam with Additional Rail

- 3.9.3.29 The thriebeam with additional rail and modified thriebeam with additional rail are L3 containment roadside barriers. They are similar to the thriebeam mentioned in paragraphs 3.9.3.19 to 3.9.3.22, except that additional rails are added at the back to enhance their containment capacity.
- 3.9.3.30 These two types of barriers are applicable where a containment capacity in excess of those of the single rail thriebeam, single rail modified thriebeam and concrete profile barrier is required but the use of high containment barrier mentioned below is not warranted.
- 3.9.3.31 In the event that the standard thriebeam with an additional rail is deemed less desirable because frequent impact by heavy vehicles is expected, modified thriebeam with an additional rail shall be used.

High Containment Barrier

- 3.9.3.32 High containment barriers are L4 containment roadside barriers. They are applicable where high containment capacity in excess of that of thriebeam with additional rail / modified thriebeam with additional rail is required at high risk locations. High containment barriers must be strong enough for the containment of heavy vehicles. If a design other than the standard reinforced concrete version is required, consideration should be given to include features in the barrier design to reduce the potential damages to light vehicles and injuries to passengers inside.

Criteria for the Provision of Safety Barrier Fences

- 3.9.3.33 The following criteria should be taken into account when considering the provision of safety barrier fences :
- (i) Barrier fences should always be provided to protect the supports of overbridges, gantries or other structures that might collapse with catastrophic effects if struck by an errant vehicle. However, lighting columns on roads with a design speed or speed limit of 50 km/h or less, and traffic signs on single posts are not included in this category.
 - (ii) Consideration should be given to provide barrier fences to shield roadside installations such as sign gantries, directional signs, traffic signs, lighting columns, fire hydrants, catchpit, pillar box, etc. from direct impact of errant vehicles to enhance passive road safety on roads with a design speed or speed limit of 70 km/h or above, unless these installations are designed to be crash worthy according to BS EN 12767 or other equivalent standards. Where the concern could not be addressed by installation of barrier fence, such as at diverging points, crash cushion may be installed according to paragraph 3.9.4.1
 - (iii) Barrier fences should normally be provided on dual carriageway roads with a speed limit or design speed of 70 km/h or greater where :
 - (a) the road is on an embankment which is 3m or more in height; or
 - (b) road is on a retaining wall which is 2m or more in height; or
 - (c) the central reservation is less than 3m in width; or
 - (d) the road is adjacent to another road, a railway or a permanent body of water more than 0.5m deep.
 - (iv) Barrier fences may be provided on single carriageway roads with a speed limit or design speed greater than 50 km/h and dual carriageway roads with a speed limit or design speed less than 70 km/h where :
 - (a) the horizontal radius is at or less than the minimum radii for 10% superelevation given in Table 3.3.3.1 of this Chapter; or
 - (b) the road is on an embankment or a retaining wall which is greater than 1.5m in height; or
 - (c) the central reservation is less than 3m wide; or
 - (d) the road is adjacent to another road, a railway or a permanent body of water more than 0.5m deep.
 - (v) Barrier fences should not normally be provided on single carriageway roads with a speed limit or design speed of 50 km/h unless hazardous circumstances prevail such as steep slope or retaining wall adjacent to the road, or sharp bend.
- 3.9.3.34 Barrier fences should not be placed on side slopes steeper than 1:6 to avoid errant vehicles mounting the barrier fences and thereby affecting the performance of the barrier fences.
- 3.9.3.35 A distance of at least 1000mm from the traffic face of safety fence or 600mm from the back of post whichever is greater should be provided for any corrugated beam barrier fences erected adjacent to the edge of a downhill slope or a retaining wall to allow the dynamic deflection of the fences during the impact. If kerbs are present, subject to the qualification in paragraph 3.9.3.44, it is desirable to set the barrier face in the same line as the kerblines.

- 3.9.3.36 For an uphill slope, the height and slope angle are the factors determining whether barrier should be provided in front of the slope. In the comparison of the severity of vehicular impacts with slope to that with safety fences, Roadside Design Guide suggested that safety fences should be provided for less severity when the slope angle is greater than 20° and the slope height is greater than 3 m.
- 3.9.3.37 If no barrier fence is provided in front of an uphill slope, attention should be given to ensure that the slope surface within a height of 1000mm from the adjacent pavement should be smooth.
- 3.9.3.38 Dynamic deflection varies according to the impact speed, impact angle, vehicle type and the characteristics of the barrier fences. For a passenger car with an impact angle of 20°, Table 3.9.3.3 gives the minimum distance to the hazard.

Table 3.9.3.3
Clearance for Various Barrier Types and Speeds

Barrier type/Speed	Distance between back of post and obstacle		
	80 km/h	100 km/h	110 km/h
W-beam barrier with posts spaced at 2m centres	0.6m	1.0m	1.0m
Standard/Modified Thriebeam barrier with posts spaced at 2m centres	0.5m	0.9m	1.1m

- 3.9.3.39 The effective safety fences should be extended far enough upstream and downstream to prevent errant vehicles from hitting the hazardous object.
- 3.9.3.40 The safety fence may be flared so that they are installed away from the kerblines as it approaches its terminal. The flaring of safety fence has several purposes as follows :
- (i) The total length of safety fences can be reduced.
 - (ii) The safety fences can be located further away from the travel lanes.
- 3.9.3.41 The disadvantage of flared fences is that the greater the flare rate, the higher the angle at which an errant vehicle can hit. Also, greater flare rate will increase the possibility of an impacting vehicle being redirected back into or across the carriageway following an impact. This situation is especially undesirable on two way carriageway where the impact vehicle could be redirected into on-coming traffic.
- 3.9.3.42 The detailed design for the required length of safety fence to shield the hazard can be referred to Roadside Design Guide and Road Design Guide.
- 3.9.3.43 As a rough guide based on the recommendations from the above references, Table 3.9.3.4 shows the suggested flare rates for safety fence.

Table 3.9.3.4
Suggested Flare Rates (1 : x) for Safety Fence

Speed Limit (km/h)	Flare rate for safety fence beyond shy line		Flare rate for safety fence inside shy line
	Weak post system with compacted earth footing	Strong post system with concrete footing	
110	15	20	30
100	15	20	30
90	12	16	25
80	11	15	21
70	10	12	18
60	10	10	16
50	10	10	15

Clearance between Barrier Fences and Carriageway

3.9.3.44 When kerbs are not existent, the horizontal clearance of barrier fences from carriageway should follow the requirements set out in Section 3.5.2 of this chapter. However, more detailed consideration is warranted when kerbs are in close proximity of barrier fences. It is envisaged that, depending on the exact position and height of the kerb, it can adversely affect the trajectory and stability of an errant vehicle during a crash. The combination of kerbs and barrier systems presents additional complications because the vehicle may not effectively interact with the barrier after hitting the kerb. For this reason, it is desirable to set the barrier face in appropriate position relative to the kerblines whilst maintaining a safe clearance from the carriageway traffic. On high speed roads with hard shoulder or marginal strip etc., there should be little difficulty in achieving the clearance requirements specified in Table 3.5.2.1 and barrier faces should not be placed behind kerbs, if any. For slower roads, it may be impractical to achieve both the clearance and kerb positioning requirements. In such circumstances, it is desirable that the barrier face be set back 200mm from the kerblines. The 200mm offset can minimize nuisance impacts (i.e. a high frequency of brush impacts) while enhancing the performance of the barrier during a crash.

3.9.3.45 Concrete profile barrier should not be set back more than 3500mm from the edge of the carriageway to reduce the probability of impacts occurring at high angles.

Selection Guidelines for different types of Roadside Barriers

3.9.3.46 Check against all following criteria. If more than one criterion is met, the barrier type of highest containment capacity should be adopted

		Criteria	Recommended barrier(s)
(i)		Meeting the criteria of paragraph 3.9.3.33 and the speed limit is lower than 70km/h	Untensioned corrugated beam barrier - W-Beam (L1)
(ii)	(a)	Meeting the criteria of paragraph 3.9.3.33 and the speed limit is 70km/h or above; or	Thriebeam barrier / Modified thriebeam / Concrete profile barrier (L2)
	(b)	The speed limit is 70km/h or above and is located at the outside curve of a bend of radius R4 or below on top of downhill slope; or	
	(c)	The speed limit is 50km/h, on R3 or below road bends adjacent to downhill slope	
(iii)	(a)	Warranted by the "Scoring System for Selection of Thriebeam with Additional Rail / Modified Thriebeam with Additional Rail" in Table 3.9.3.5 below or the latest scoring system promulgated by the authority; or	Thriebeam with additional rail / Modified thriebeam with additional rail (L3)
	(b)	Under any special considerations deemed necessary by the designer and agreed by the authority. Designers should exercise judgement to consider the use of higher containment barriers where accident risks are very high and the consequences of accidents are serious.	
(iv)	(a)	For high risk road sections where maximum containment is warranted.	High containment barrier (L4)

Table 3.9.3.5
Scoring System for Selection of Thriebeam with Additional Rail / Modified Thriebeam with Additional Rail

Road Characteristics	Criteria	Score
Speed limit	Speed limit \geq 70 km/h	0.23
Height of road above ground or downhill slope	Height \geq 20 m	0.19
Bus usage	Number of bus routes \geq 10	0.19
Road geometry	Undesirable road geometry (See Note 3)	0.14
Traffic volume	Annual Average Daily Traffic (AADT) \geq 30,000 (one-way)	0.07
Percentage of commercial vehicles	Percentage of commercial vehicles \geq 20%	0.05
Features under road	Residents, schools, hospital or other similar occupants, or a water body, or expressways / trunk roads exist in the vicinity.	0.08
Accident records	Frequent barrier impact accidents occurred (See Note 4)	0.05
Total		1

Note 1: Thriebeam with Additional Rail / Modified Thriebeam with Additional Rail are warranted for a road section with a combined score of more than or equal to 0.70.

Note 2: For individual assessment of score, a value of zero shall be adopted if the respective criterion is not satisfied.

Note 3: Undesirable road geometry refers to a road section with radius less than 250 m for posted speed limit greater than or equal to 70 km/h, with radius less than 88 m for posted speed limit less than 70 km/h, with gradient greater than 8%, or at or within 20 m from junctions or interchanges.

Note 4: Frequent barrier impact accidents refers to more than 10 accidents in 5 years. For new construction, accident records may be conservatively assumed to be frequent where the likelihood of such accident rate is high.

End Details of Barrier Fences

3.9.3.47 Proper design on the ends of safety fences is crucial in order that the damage to occupants of the errant vehicle could be minimized during a crash. For details, refer to the Guidelines for Design of End-details of Thrie-beam Barrier Fence (HQ/GN/10) and the Supplementary Guidelines for Design of End-details of W-beam and Concrete Profile Barriers published by the Highways Department.

Parapet

3.9.3.48 A parapet is a structural component installed along the edge of a bridge or similar structure intended to prevent vehicles or pedestrians from falling off. For types, details and uses of parapets, refer to Chapter 15 of the Structures Design Manual for Highways and Railways.

Enquiries

3.9.3.49 Enquiries on details in design of barrier fences and the selection guidelines for different types of barrier fences should be made to the Research & Development Division of Highways Department.

3.9.4 Crash Cushions

- 3.9.4.1 Where fixed objects cannot be removed, relocated or shielded by appropriately oriented barriers, crash cushions may be provided to slow down a vehicle to a safe stop for head-on impacts or redirect a vehicle away from the fixed object for side impacts so that the potential for serious injury to its occupants is eliminated.
- 3.9.4.2 Most crash cushions perform their functions by the principle of kinetic energy absorption or momentum transfer. Some crash cushions use a combination of these principles.
- 3.9.4.3 Different types of crash cushions possess different functions. The crash cushion type which suits Hong Kong most shall be able to withstand head-on, side-angle and reverse-angle impacts up to the design speed that the crash cushion can withstand. Where feasible, the design speed shall be taken to be the posted speed limit plus additional safety margin speed of 10 km/h to take into account the possible speeding of a vehicle. If there is not enough space to install the crash cushion with design speed taken to be the posted speed limit plus 10km/h due to site constraints, the design speed may be lowered to equal to the posted speed limit or 50km/h, whichever is the higher. Furthermore, the crash cushion shall be able to perform the following characteristics :
- (i) The crash cushion shall not allow the impacting vehicle to pass through the attenuator when it is struck at an angle on the front or "nose" to avoid the potential for secondary impacts.
 - (ii) It shall redirect vehicle in all designed side impacts on the unit at angles not exceeding 20° back to the originally travelled direction at no greater than 60% of the impact angle to avoid the potential for secondary accidents with vehicle travelling in adjacent travel lane.
 - (iii) The crash cushion shall be designed to be free from any protruding elements that may cause an errant vehicle to change direction in an uncontrolled manner that will increase the potential for secondary accidents.
 - (iv) It shall also possess anti-climb characteristics to ensure that impacting vehicle will not roll over the system.
- 3.9.4.4 To ensure a crash cushion type satisfies the above required characteristics, it shall meet the evaluation criteria of *National Cooperative Highway Research Program (NCHRP) Report 350* of U.S.A. for different test levels 1 (50 km/h), 2 (70 km/h) and 3 (100 km/h). The crash cushion must be compliant with three dynamic performance evaluation criteria that are structural adequacy, occupant risk and post-impact vehicular trajectory.
- 3.9.4.5 The crash cushion so chosen should be wide enough to shield the ends of median barriers or other hazardous objects.
- 3.9.4.6 A transition section is needed between the back of the system and the barrier when the crash cushion cannot be attached directly to a median barrier or there exists a gap between them. Such transition section should also be provided if the median barrier terminates in sloping end.
- 3.9.4.7 The road surface on which the crash cushion is installed must be free from kerbs. The path between the carriageway and the crash cushion should be clear of any obstruction or irregularities. In addition, for structures, they should be placed free of joints.
- 3.9.4.8 Retroreflective sheeting should be provided on the nosing of a crash cushion to make it more conspicuous at night and during inclement weather. The required visibility distance for a crash cushion is stipulated in Table 3.3.5.1. When the sight distance is below the desirable minimum sight distance, an illuminated traffic bollard should be erected behind the crash cushion. Highways Department standard drawing No. H 2265 for the typical arrangement refers.

3.9.4.9 Since the crash cushions are proprietary products, the dimensions corresponding to any particular design speed that they are designed to cater for are varied for different products. It is therefore desirable to obtain the dimensions of those crash cushion available in the market. For design of new highways, the largest size of the available product in the market in respect of the design speed should be allowed for. Further, the necessary chevron road markings should be so designed to allow for the proposed crash cushion to be installed with sufficient horizontal clearance as specified in Table 3.5.2.1.

3.9.4.10 Crash cushions are desirable to be provided under the following criteria :

- (i) For high speed road with a speed limit of 70 km/h or above; and
- (ii) In front of the non-crashworthy terminal* of barriers which are located at the diverging point for main roads and/or slip road where there is no other effective means to alleviate possible serious injury to vehicle occupants for head-on or side impacts.

* Non-crashworthy terminal is a terminal that cannot meet all of the evaluation criteria listed in NCHRP Report 350 for each of the required crash tests.

3.9.4.11 Apart from the above criteria, crash cushion may be considered on individual basis for deployment in front of potential hazard or fixed isolated obstruction (e.g. bridge column) where traffic is required to travel in close proximity.

3.10 Road Tunnels

3.10.1 Geometric Design Standards

3.10.1.1 It is important that the geometric design standards in Tunnels should take into account those used on the approach roads, and as far as possible no discontinuity in the route occurs, and the capacity in the tunnel is the same as on the approach road. Each case will however need to be considered on its own merit, according to economic and other relevant factors.

3.10.2 Road Cross Section in Tunnels

3.10.2.1 Whilst it may be economic to reduce the carriageway width, it should be remembered that the effective carriageway width in a tunnel is in fact generally less than on the approach roads because of the double white line system used for lane control. A further reduction of effective width may also be induced because of the effects of "kerb shyness", though this may be difficult to determine.

3.10.2.2 To counter act the effects, of "kerb shyness" and the double white line system, for road safety reasons it is recommended that a 500mm marginal strip be provided on both sides of the carriageway in each tube.

3.10.2.3 It is essential that a walkway be provided on both sides of the carriageway to enable maintenance to take place, allow access to emergency telephone equipment, and, provide sufficient width for doors of emergency equipment to be opened without encroaching onto the carriageway. Past experience has found that raised walkways are preferable for safety reasons and the minimum height of walkway above the carriageway is recommended to be 500mm. The maximum height of the walkway should not exceed 650mm unless staircases can be provided from the carriageway to allow drivers from broken down vehicles to gain access to the emergency equipment. It is also recommended that the walkway including the side or vertical face should be constructed of material that is of a different and contrasting colour to the carriageway surface.

3.10.2.4 Carriageway and walkway dimensions are summarised in Table 3.10.2.1.

Table 3.10.2.1
Summary of Carriageway and Walkway Dimensions in Tunnels

<u>Carriageway width</u>	<u>Single Tube Tunnel</u>		<u>Dual Tube Tunnel Dimensions for each one way single carriageway tube</u>	
	<u>Desirable(m)</u>	<u>Minimum(m)</u>	<u>Desirable(m)</u>	<u>Minimum(m)</u>
2-lane	7.3	7.3	7.3	6.75
3-lane	-	-	11	10 ⁽¹⁾ (for speed limit of 50 km/h only)
4-lane ⁽²⁾	-	-	14.6	13.5
Marginal Strip	0.5	0.5	0.5	0.5
Walkway width	1	0.8	1	0.8
Height of Walkways	0.65 ⁽³⁾	0.5	0.65 ⁽³⁾	0.5

(1) A 10m wide dual 3-lane carriageway can only be adopted on a very special case and prior approval from TD is required.

(2) It is undesirable to use a 4-lane carriageway for economic reason

(3) If staircases from the carriageway are provided at regular intervals this may be increased.

3.10.2.5 Both vertical and horizontal clearances should conform to those given in Tables 3.5.1.1 and 3.5.2.1 respectively. In respect of vertical clearances, overhead traffic signals, signs, lighting units or similar must not project below the minimum vertical clearance. The vertical clearance is provided between the ceiling and the structure gauge for the installation of traffic aids and surveillance equipment.

3.10.2.6 Diagram 3.10.2.1 shows a typical cross section for two tunnel types.

DIAGRAM 3.10.2.1 : TYPICAL TUNNEL CROSS SECTION

2 - LANE CARRIAGEWAY

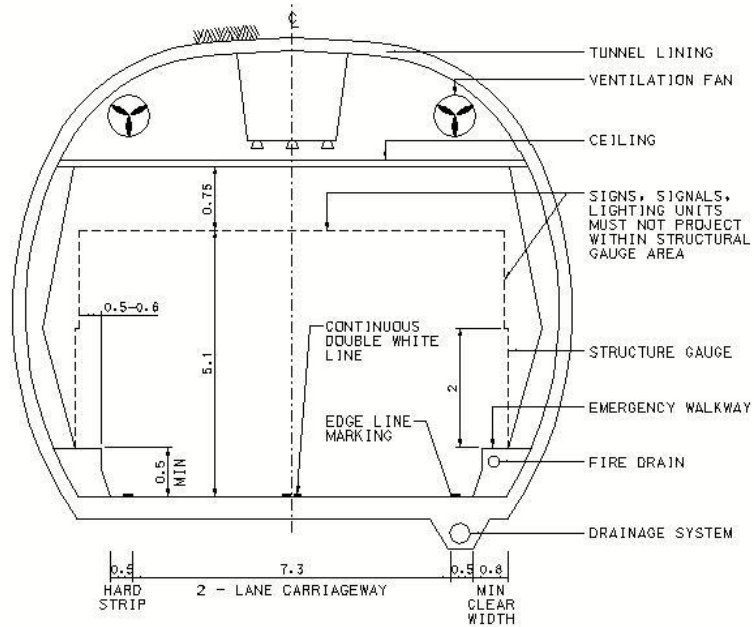

3 - LANE CARRIAGEWAY

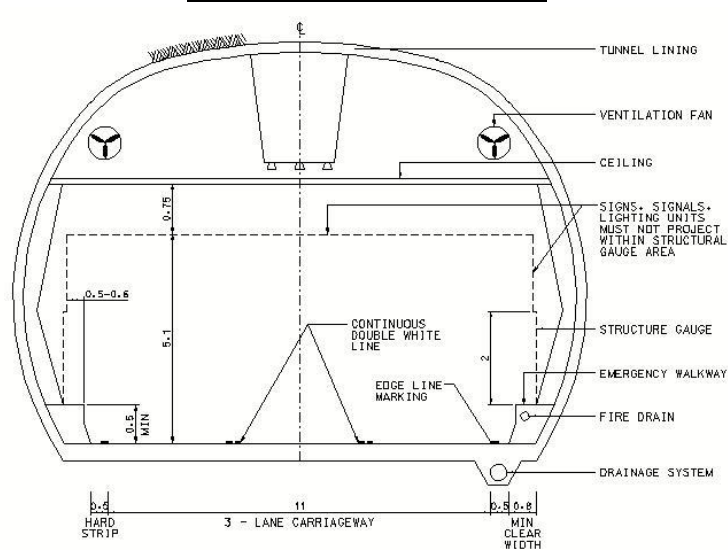

NOT TO SCALE

NOTE: ALL DIMENSIONS ARE IN METRES

3.10.3 Signing and Signalling for Tunnels

3.10.3.1 The signing and signalling for Tunnels should conform to Volume 3.

3.10.4 Lighting for Tunnels

3.10.4.1 More lighting should be provided at the entrance of tunnel than is usually provided within, to enable motorists in the daytime to adapt more quickly to the darker environment inside it from the relatively bright environment outside. It is particular important from road safety point of view.

3.10.5 Tunnel Portal Area

3.10.5.1 Various equipment and facilities are installed near the tunnel portal areas. Vehicles travel at high speed in these areas and consequences of any collisions onto roadside installations can be serious. The following considerations should be given:

- i. For any installations on the roadside and medians, horizontal clearance under Table 3.5.2.1 of Volume 2 shall be provided from the carriageway.
- ii. Barrier fences and crash cushions should be provided to shield the roadside installations unless they are designed to be crash worthy.
- iii. Barriers and/or railings should be erected for the protection and segregation of the pedestrians, especially the bus passengers, from the live traffic.
- iv. Proper transition of barrier fences and appropriate treatment to any sharp point, blunt end and opening in the roadside barriers should be provided.
- v. Locations of entries and exits should be carefully considered to avoid causing unnecessary safety hazard during operation stage.
- vi. The above considerations should also be covered during contra-flow operations. Other than tunnel users, the design should take into account the need of tunnel operations, e.g. provision of staff / maintenance access.

Please refer to Section 3.9.3 and 3.9.4 of Volume 2 for details of item ii and iii.

3.10.5.2 Parking of recovery vehicles on the carriageway of tunnel portal areas should be provided off the road. If unavoidable, proper barrier fences and Movable Steel Barrier fences, preferable remote controlled, should be considered to shield the recovery vehicles from live traffic.

3.11 Single Track Access Roads

3.11.1 Introduction

3.11.1.1 In many rural and urban fringe areas there are small isolated developments which will only generate low vehicular and pedestrian flows and to which it would be both difficult and expensive to construct normal two lane roads. In such cases a single track access road with passing bays may be adequate.

3.11.1.2 Many single track access roads have already been constructed, both legally and illegally, and where properly planned have been found to operate efficiently. The main reasons for a single track road not working efficiently are :

- (i) Inadequate provision of passing bays which are not intervisible.
- (ii) Inadequate provision of parking spaces resulting in passing bays, footpaths, verges or even the road being used for illegal parking.
- (iii) Excessive or unsuitable land uses resulting in high traffic flows.
- (iv) Motorists driving too fast.
- (v) Road works or other construction works requiring partial/complete closure of the road.

3.11.1.3 This section sets out guidelines for the planning and design of single track access roads. Where a desirable minimum is given, this is normally the absolute minimum for a design speed of 50km/h, whereas the absolute minimum quoted is that for a design speed of 30km/h.

3.11.1.4 It should be noted that some of these traffic engineering standards are lower than for normal roads. However, within the constraints imposed when upgrading existing tracks, it is appreciated that difficulty may still occur in fully achieving the new standard. The designer should consider together with the Traffic Engineer the relevant implications and agree whether a lower standard improvement is acceptable.

3.11.2 Use

3.11.2.1 Whenever a single track road is being considered the appropriate Regional Office of Transport Department should be consulted at an early stage to obtain their approval in principle.

3.11.2.2 Single track roads with passing places maybe provided where traffic flows will be light and where there is, or will be, little or no kerbside activity. Their use will therefore be most appropriate as access roads to isolated rural villages, urban fringe areas, minor recreational areas, or similar facilities with low trip generation.

3.11.2.3 Where any new road is constructed it will be likely to generate additional traffic and open up an area for further development. Both factors must be carefully considered when deciding whether a single track road would be adequate to serve an area.

3.11.3 Design Flows

3.11.3.1 Whilst it has been found that a single track road when provided with adequate passing places can accommodate 2-way flows of 100 vehicles per hour, this should not be used as a design figure. This flow would only be acceptable as an isolated peak flow but not a regular daily occurrence. The normal daily 2-way traffic flow should not exceed 500 vehicles per day. The effect of long vehicles using the road should be considered when estimating traffic flows as they tend to reduce the capacity.

3.11.4 Horizontal Alignment

- 3.11.4.1 Whilst topography will often pose a constraint the alignment should be as straight as possible to maintain sightlines and reduce the need for passing bays. It has been found that one of the most efficient layouts is one where the bends are incorporated into passing bays which should be suitably widened and/or lengthened.
- 3.11.4.2 For curves other than hairpin bends mentioned in 3.11.4.3 the minimum radius of curvature measured along the inner edge of the carriageway are :
For 50 km/h - 44m
For 30 km/h - 30m
- 3.11.4.3 At some locations it may be necessary to provide hairpin bends. Where these are provided on steep roads the gradient should be reduced through the bend. The inner radius maybe zero though the outer radius should be sufficient for the largest vehicle likely to use the road. Provision should be made at or near the bend for vehicles to pass.
- 3.11.4.4 Transition spirals are not necessary and any widening should be applied along the outer edge of the carriageway.
- 3.11.4.5 Single track roads should have a crossfall of 2.5%. On bends the crossfall should normally be such as to provide a superelevation of 2.5% though in some cases there may be a clear case on safety grounds to increase the superelevation, in particular on steep roads with sharp bends.
- 3.11.4.6 Superelevation should be applied over the section of road immediately prior to the commencement of the inner horizontal curve. The rate of change of crossfall should be between 1% and 2%.

3.11.5 Sightlines

- 3.11.5.1 Where the road is single track a motorist should be able to see between one passing bay and the next. A desirable minimum stopping sight distance is 50m and an absolute minimum 30m, although at hairpin bends or similar hazards where speeds will be very low, a lower sightline distance will need to be accepted. Care is required where only the minimum sight distances or even smaller sight distances are provided that vehicle speeds can be adequately controlled and that hazards to vehicles travelling in opposite directions are avoided in particular.

3.11.6 Vertical Alignment

- 3.11.6.1 Where the road is to be used by large or heavy vehicles the maximum desirable gradient is 10%. For smaller, lighter vehicles the maximum desirable gradient is 16%. If the terrain necessitates a steeper road the design engineer should consider the following before exceeding the 16% desirable maximum :-
- (i) length of gradient which is to exceed 16%.
 - (ii) Visibility
 - (iii) Type of vehicles to use the road - Emergency vehicles would not normally operate at gradients in excess of 16%, and public service vehicle operators may refuse to use those roads.
 - (iv) Topography - alternative but longer routes
- 3.11.6.2 On any steep section of road particular attention will need to be paid to the texture of the finished road surface to ensure that adequate frictional resistance can be provided.

3.11.6.3 On single track road the inner edge of the carriageway on a horizontal curve should be used as the vertical control line. Vertical curves should be at least 10m long. At summit curves special consideration will need to be given to maintaining adequate stopping sight distances and in these locations a desirable minimum K value is 3 with an absolute minimum K value of 1.

3.11.7 Minimum Carriageway Width

3.11.7.1 As the roads serve as an Emergency Access for fire engines a minimum carriageway width of 3.5m should be provided.

3.11.7.2 Suitable widening should be provided on bends though it has been found that, due to sightline constraints, a two lane carriageway will often be required.

3.11.7.3 At passing bays, lay-bys and elsewhere where a two lane section of road is required a nominal carriageway width of 6.0m should be provided, with appropriate widening on bends as shown in 3.11.7.6.

3.11.7.4 At junctions with other roads the carriageway should be widened to at least 6.0 m. The length and width of the widened section must be sufficient to allow the largest likely vehicles to manoeuvre safely and this assumed vehicle length should not be less than 12m. In particular at a junction with a more major road, traffic turning right from the major road should not be obstructed by traffic waiting to exit from the minor road.

3.11.7.5 A planning reserve should be provided to allow for future widening of the carriageway to at least 6m (with appropriate widening on bends), and the need for an even wider carriageway must be considered. In addition allowance should be made for additional footpaths and any engineering support works.

3.11.7.6 Table 3.11.7.1 is an indication of appropriate widths on straights and bends:

Table 3.11.7.1
Widths on Straights and Bends

<u>Inner Radius</u>	<u>Single Lane</u>	<u>Two Lane</u>
Straight	3.5m	6.0m
150m	3.5m	6.0m
100m	3.8m	6.3m
75m	4.0m	6.5m
50m	4.3m	6.9m
40m	4.5m	7.2m
30m	4.8m	7.8m
25m	5.1m	8.2m
20m	5.4m	8.7m
15m	5.9m	9.6m
10m	6.6m(8.0)	10.9m
5m	8.0m(10.0)	13.5m
0m	9.0m(14.0)	16.5m

(-) The figures in brackets are the widths required for long wheelbase vehicles.

3.11.8 Footpaths and Verges

3.11.8.1 Footpaths should be provided where necessary to cater for pedestrian needs and should be routed, as far as possible, along the main desire lines. In particular it may be desirable to provide a separate footpath network. The minimum widths of footpaths should be 1.6m. In cases where the footpath is obstructed by lamp posts, fire hydrants, traffic aids etc. widening of the footpath may be required to ensure that an effective clear width of at least 1.0m is provided and the obstructions should be placed at the rear of the footpath.

- 3.11.8.2 A footpath along one side of a road will normally suffice except where there is development on both sides. Footpaths should be provided fronting any development along the road.
- 3.11.8.3 Where the footpath is adjacent to the road a raised kerb should be provided. Consideration may also need to be given to ways of preventing illegal parking on the footpath. Separating the footpath from the carriageway by means of a raised verge or suitable railings as stated in paragraph 3.9.2.12 will reduce the risk of misuse by vehicles. Both footpaths and verges should be capable of discharging storm water from the carriageway (at appropriate points), from the footpath or verge, and from any adjacent slopes.
- 3.11.8.4 Where footpaths are not required a verge should be provided with the following minimum widths :-
- | | | |
|-------|--|------|
| (i) | Against cuttings | 0.5m |
| (ii) | Above embankments | 1.5m |
| (iii) | On a structure with protective parapet | 0.5m |
- 3.11.8.5 The verge treatment should be capable of defining the edge of the carriageway and supporting the edge of the carriageway construction. It should discourage use by vehicles other than in an emergency.
- 3.11.8.6 Where U-channels are provided in footways they should be covered.
- 3.11.9 Passing Places and Lay-Bys**
- 3.11.9.1 The main criterion for passing places is that they should be intervisible and hence the most appropriate locations will be bends and midway between bends. Where forward visibility is unrestricted passing places should be provided at intervals of approximately 60m (measured from the end of one to the start of the next) consistent with adjacent topography and land tenure.
- 3.11.9.2 The passing bays should preferably not be sited on the inside of curve or on sharp crest. Where practical on steep gradients the passing bays should be on the 'downhill' side so that motorists travelling downhill pull into them thus permitting the uphill motorist to continue without having to stop.
- 3.11.9.3 Each passing place should preferably be at least 12m long to accommodate two light vehicles, plus nominal tapers of 1:3. Where larger vehicles are expected the passing bays should be lengthened accordingly. The carriageway width at passing places should be increased to a nominal 6m. Passing places maybe signed with Traffic Sign 620 (TC 313).
- 3.11.9.4 Lay-bys must be provided at those locations where there is a need for vehicles to stop to load or unload. Their dimensions should be similar to passing bays.
- 3.11.10 Parking**
- 3.11.10.1 Consideration must be given to the parking requirements and it is recommended that provision for parking should be made in areas off the road. The use of passing places, lay-bys and turnarounds for parking should be discouraged as their use would lead to significant reductions in the capacity and efficiency of the road.
- 3.11.10.2 The effect of parking on the verges needs to be considered and, where this is not acceptable, suitable deterrent measures incorporated.

3.11.11 Turning Facilities

- 3.11.11.1 These should be provided at the end of the road and appropriate locations along the road. Typical layouts are shown in diagrams 3.4.5.1 and 3.4.5.2 in Section 4 of this Chapter. It should be noted that a turning 'tee' takes up less area than the equivalent turning circle. Adequate parking facilities should be provided nearby to prevent turning facilities being misused for illegal parking.

3.11.12 Traffic Aids

- 3.11.12.1 Traffic signs on single track roads should be kept to a minimum. Where traffic signs or other traffic aids are considered necessary, the land status should be checked to ensure they will not be erected on private land.
- 3.11.12.2 Where a road is initially two lane for a short section prior to becoming a single track road, traffic sign 604 (TC 304) "Single track road with passing places" should be erected.
- 3.11.12.3 The speed limit will normally be 50 km/h, even when the road is designed to a lower speed. A lower speed limit should only be introduced where the Police are able to adequately enforce it, not just as a means to indicate to motorists that the road is designed to a low speed.
- 3.11.12.4 The use of road humps should be considered at appropriate locations as a means of controlling vehicle speeds. Further advice is given in Chapter 5 of this Volume.
- 3.11.12.5 Where there is no street lighting, or the lamps are more than 200 metres apart, and there is a likelihood of illegal parking then traffic sign PA 6 (TS 286) may be erected. However the use of this sign should be restricted to those locations where illegal parking is a problem. The sign must not be used where there is a system of street lighting with the lamps less than 200 metres apart.
- 3.11.12.6 Unless there is a need to control the type of vehicle using parking spaces these maybe designated by the marking alone.
- 3.11.12.7 Passing bays should normally be signed by means of traffic sign 620 (TC 313).
- 3.11.12.8 Bends would not normally be signed though on very sharp or hairpin bends a chevron sign 414 (TC 210) or black and white markings on the outer kerb or barrier may be appropriate particularly if the road is unlit.
- 3.11.12.9 Railings would not normally be appropriate on these roads other than where there is a steep drop with insignificant level difference behind the footpath.
- 3.11.12.10 Safety fencing would only normally be required on the outside of very sharp bends or on structures where there is a steep drop. At other locations a concrete upstand would probably suffice.

3.11.13 Use by Public Transport

- 3.11.13.1 These roads would not normally be considered suitable for use by buses but would however be suitable for use by minibuses and taxis. Depending on the type of facility which each road serves, they may be used by coaches. Consideration should be given to providing suitable facilities for GMB's and taxis to turn round and wait close to villages and other locations where the public would be most likely to require public transport.

Annex**Guidelines on Design of Railings**

- a) The design of pedestrian railings should generally comply with BS 7818. In actual design, the principal design requirements including safety provisions should be outlined taking into account the local experience.
- b) The design should be simple, unobtrusive, having colours coherent with the surrounding environment and using minimum materials.
- c) Railings should be designed to withstand the envisaged loading.
- d) Railing elements should not become easily detached on impact when they are placed adjacent to a carriageway.
- e) Railing components should be designed, when being struck, to minimize the risk of presenting a hazard to pedestrians or occupants of impacting vehicles. In particular, the design should alleviate two specific hazards:
 - (i) detachment of horizontal rails, particularly top rail with substantial rigidity, which could impale vehicles; and
 - (ii) detachment of infill bars or other components, which could become dangerous projectiles.
- f) Railing components should be free from burrs and sharp edges.
- g) Railings should be designed to avoid entrapment of children's heads/limbs in gaps (relevant provisions in BS EN 1176). Accordingly, openings or gaps in the railings should either do not allow passing a 110mm diameter rigid sphere or allow passing of 230mm diameter rigid sphere.
- h) Enquiries on the design of railings should be addressed to the Research and Development Division (on engineering aspects) and Landscape Unit (on aesthetic aspects) of HyD.

TPDM Volume 2 Chapter 4 – Junctions

4.1 References

1. Department of Transport - TD 42/95 - *Geometric Design of Major/Minor Priority Junctions*
2. Department of Transport - TA 23/81 - *Determination of Size of Roundabouts and Major/Minor Junctions*
3. Transport and Road Research Laboratory - TRRL LR492 (1980) - *The traffic capacity of roundabouts*
4. Transport and Road Research Laboratory - TRRL SR582 - *The traffic capacity of major/minor priority junctions*
5. Department of Transport - TD 16/84 - *The Geometric Design of Roundabouts*
6. Department of Transport - TA 42/84 - *The Geometric Design of Roundabouts*
7. Department of Transport - H 12/76 - *Design of weaving areas for motorways and all purpose roads*
8. Department of Transport - H 18/75 - *Design of rural motorway to motorway interchanges - merging and diverging lanes*
9. Department of The Environment - *Layout of Roads in Rural Areas, 1968*
10. Department of The Environment - *Roads in Urban Areas, 1966*
11. Department of Transport - TD 9/81 - *Highway Link Design*

4.2 Junction Design - General

4.2.1 Introduction

4.2.1.1 Junction design is the most important factor affecting safety and efficiency of movement within a road network. This chapter contains information to assist the designer in choosing the most appropriate type of junction control and designing the optimum layout for that junction type.

4.2.2 Junction Types

4.2.2.1 Junctions can be divided into four main types, viz *Priority Junctions*, *Signal Controlled Junctions*, *Roundabouts* and *Grade Separated Intersections*.

4.2.2.2 *Priority Junctions* operate on the basis that traffic on the major road has continual priority over the traffic on the minor road. Minor road traffic is controlled by “stop” and “give way” signs and associated carriageway markings. The onus is entirely on the minor road traffic to decide when it is safe to enter the major road. Section 4.3 of this chapter covers Priority Junctions.

4.2.2.3 *Signal Controlled Junctions* operate on a time sharing basis. Traffic streams are allowed to enter the junction for a period of time, indicated by an illuminated signal, and during which period conflicting traffic streams are halted. Volume 4 of this Manual deals comprehensively with Traffic Signals. Brief mention is made in Section 4.4 of this chapter purely for reference purposes.

4.2.2.4 *Roundabouts* could be considered as a form of channelized Priority Junction. Vehicles enter a one way carriageway and move in a clockwise direction around a central island. Entering vehicles give priority to those vehicles already circulating across their entry. Section 4.5 deals with Roundabouts.

4.2.2.5 *Grade Separated Intersections* are junctions where some or all of the intersecting roads pass each other at different levels. Some or all of the turning movements are catered for by ramps connecting the two levels. Types of interchange and design considerations are covered in Section 4.6.

4.2.2.6 Junctions may be formed by a combination of two or more of the four basic types described above. For example grade separation of two major roads with connecting ramps terminating at roundabouts is quite common.

4.2.3 Junction Capacity

4.2.3.1 It is not possible to assign specific thresholds of flow at which one particular method of junction control becomes more viable than the alternatives. Diagram 4.2.3.1 may be useful to designers when considering options for a site catering for design flows at the lower end of the scale. For single carriageway roads it shows the approximate levels of design flow at which various standards of T-junction priority control are required. For dual two lane carriageways priority junctions are unlikely to be viable where the minor road flow is expected to exceed about 3,000 vehicles AADT two way. For dual three lane carriageways priority control is never recommended.

4.2.3.2 At design flows above the capacity of priority junctions the choice between traffic signals and roundabout will generally be made, based on factors other than capacity. Both types of junction control, with suitable layout, are capable of handling the range of flows between priority control and grade separation. As a general principle however, the higher the ratio of major to minor road flow the more appropriate is the signal control. Roundabouts are most appropriate with balanced major and minor road flows, high percentages of right turning movements and low pedestrian volumes.

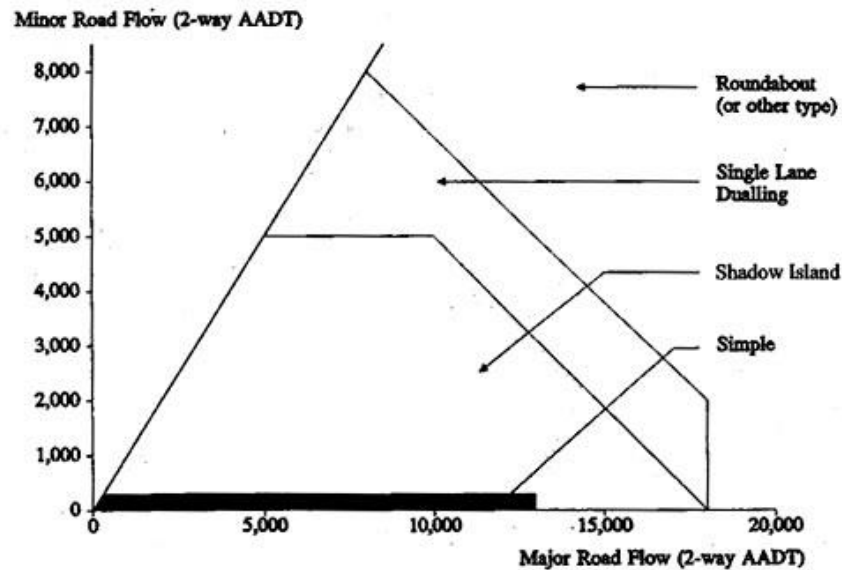
DIAGRAM 4.2.3.1 : SINGLE CARRIAGEWAY T-JUNCTION PROVISION**4.2.4 Design Flows**

4.2.4.1 In designing and evaluating all junction types it is necessary to predict design flows, which should be peak hour volumes, for a future year not less than 10 years after scheme implementation. The junction design needs to provide adequate capacity to handle the predicted flows in the design year.

4.2.4.2 Despite the sophisticated modelling techniques available, prediction of traffic flows for a distant year is far from precise. It is suggested therefore that a range of flows be considered by adopting a confidence limit of 20%. Within this range site specific factors would determine the design flows to be adopted. For example, if subsequent adjacent land development would preclude the further improvement of a particularly strategic junction, it would be imperative that adequate capacity was provided in the first design. In this case the design flow adopted would be the top of the confidence range.

4.2.4.3 In considering design flows consideration should also be given to hourly, daily and seasonal variation at the particular site in question. For example junctions feeding the Container Port are subject to particularly high infrequent peaks corresponding with trading quota deadlines etc. In this case the design flow may need to be considerably higher than the average future flow predicted by the model.

4.2.4.4 Where short duration queuing is expected to be a particular problem, allowance should also be made, in deriving the design flow, for short term variation within the peak hour. For the manual calculation of capacities, described in the sections on priority junctions and roundabouts, it is suggested that an increase of 10-15% be applied to the peak hour flows to allow for this occurrence. (Short term variation is automatically taken account of in the computer program assessment.)

4.2.5 Delay

4.2.5.1 Obviously delay is closely related to capacity and design flow as described in the previous two sections. As the design flow approaches the capacity of the junction delays will increase. In this introductory section it is considered worthwhile to briefly examine aspects of delay at the different junction types.

4.2.5.2 At priority junctions delay will be experienced only by the minor road traffic. Major road traffic will flow virtually unimpeded almost to the point where the major road flow equals the major road capacity. Before this point is reached however the delays to vehicles on the minor road will have reached intolerable proportions. Long delays to minor road traffic also encourage smaller gap acceptance and a consequent increase in accidents.

4.2.5.3 Unlike priority junctions traffic signals can distribute delay fairly so that no particular movement suffers disproportionate delays. At low levels of flow however, total delay at a junction will increase when compared with a priority layout. Minimum cycle times are required by safety considerations and where this cycle time is greater than that warranted on capacity grounds unnecessary delay results. This problem is particularly prevalent at very off peak times, such as the middle of the night, despite the facility with all modern controllers to vary phase and cycle times throughout the 24 hours. Delays can of course be minimised by linking adjacent traffic signal controlled junctions.

4.2.5.4 With well balanced flows delays at roundabouts will be minimised over a full range of flow up to levels which are close to capacity. Problems can arise with single predominant flows causing long delays to those traffic streams across whose entry they pass. Also roundabouts should be avoided in locations covered by Area Traffic Control.

4.2.5.5 Delays to major through movements are abolished completely at grade separated interchanges while delays to minor turning movements can be minimized by use of appropriate junction control where the ramps and minor roads intersect.

4.2.6 Safety

4.2.6.1 Junction accidents are defined as those occurring at or within 20 metres of a junction and as the influence of a junction can extend far beyond 20m the actual percentage of accidents attributable to junctions is probably even greater than this figure.

4.2.6.2 The high difference in speed between through and turning traffic at priority junctions, together with the total dependence on the judgement of minor road drivers to determine what is a safe gap in the major road traffic stream, leads to a high accident rate with this type of junction. Refuges can greatly improve safety standards at priority junctions.

4.2.6.3 The positive indication provided to drivers by traffic signals generally results in a low accident rate at this type of junction. Numbers of right turning and pedestrian accidents are particularly reduced when compared to priority junctions. Rear end accidents usually increase in frequency however owing to vehicles stopping suddenly when lights change. This problem can be particularly acute with traffic signal installations on high speed roads.

4.2.6.4 Speeds of vehicles in the roundabout are usually low and compared with other junction types vehicle paths intersect at small angles. When accidents do occur they tend to be less severe than with other at-grade junction types.

4.2.6.5 At grade separated intersections major flows are free flowing with a minimum of accidents occurring at points of merging and diverging. At such points paths intersect at small angles but the high speeds of vehicles involved may result in increased severity of accidents.

4.2.7 Economic Considerations

4.2.7.1 Ignoring decisions which are made for political expediency, the type and scale of junction provided is ultimately governed by economic considerations. The cost of provision of a junction in terms of construction costs and land costs etc. can be weighed against the monetary benefits which accrue from reduced delay and savings in accidents etc. and the scheme producing the best value of money is the most appropriate scheme.

4.2.7.2 Priority junctions are generally the cheapest in terms of construction cost and are therefore the most viable at low flows where delays and accident rates are low. At the top end of the flow range where substantial widening and channelization are required, the additional land take may prove uneconomical when compared to a more compact traffic signal design.

- 4.2.7.3 Traffic signals can be relatively economical in the use of land which will normally more than offset the cost of equipment. High capacity can be achieved through multi lane approaches, developed over a relatively short distance, thereby minimising the junction area.
- 4.2.7.4 Conventional roundabouts are always more extravagant in their use of land than traffic signals with equivalent capacity. Opportunity costs for the alternative land uses will therefore constitute a major factor. On the other hand small roundabouts do not use large amounts of land, sometimes less than both signals and priority junctions with large scale channelization.
- 4.2.7.5 Grade separated interchanges are far and away the most expensive in terms of construction cost irrespective of location. However in the Territory, where construction costs are sometimes dwarfed by land costs, compact grade separated designs may represent an economic alternative. Grade separated interchanges in rural areas are generally expensive in terms of land take as the opportunity cost of alternative lane uses may be low. However, in urban areas compact grade separated schemes have proved more cost effective than exclusively at-grade schemes requiring greater land take. The simplest example of compact grade separation is a flyover spanning one or more at-grade junctions, where the flyover is constructed within the at-grade road reserve, and turning movements are catered for below the elevated structure.
- 4.2.7.6 An important aspect of the economic consideration is the feasibility of staged construction. Economic benefits may be obtained by deferring construction of part of a junction layout until traffic volumes increase sufficiently to warrant the more extensive design. Some junction types lend themselves more readily to staged construction than others, though more often the feasibility of staged construction will depend on the topography and traffic flows at the particular site. Junctions constructed initially as priority control lend themselves readily to future conversion into signal control and to a lesser extent small roundabouts. Planned conversion to a conventional roundabout design would normally require the uneconomical sterilization of a large area of land in the intervening years. Both conventional roundabouts and the larger traffic signal controlled junctions lend themselves to future conversion into grade separated junctions.

4.2.8 Pedestrian Considerations

- 4.2.8.1 It is important that the needs of pedestrians are given equal importance to the needs of vehicular traffic in junction design. Forecasts of future pedestrian demand should be given equal priority with the design year vehicular predictions and the junction design tested to ensure adequate capacity and minimum delay for pedestrians. Details of pedestrian capacities, design flows and pedestrian crossing locations are given in Section 7 of Chapter 3 of this volume. The following paragraphs briefly examine the possible advantages and disadvantages of the different junction types in respect of pedestrian facilities.
- 4.2.8.2 Priority junctions in general are easy to negotiate for pedestrians and intended routes through the junction should be indicated with guardrailing. Physical islands offer refuge to pedestrians, allowing them to cross different directions of traffic in stages. Shadow islands do not offer the same protection and should not be relied upon in designing a junction to accommodate pedestrians. As pedestrian volumes increase, controlled crossings may be required on one or more arms of the junction and can be quite compatible with priority control. Heavy pedestrian flows at priority junctions may warrant the inclusion of footbridges or subways, however one should bear in mind the reluctance of pedestrians to use such facilities if vehicular traffic is light.
- 4.2.8.3 Traffic signals offer the safest and most efficient way of dealing with pedestrians at-grade. With light pedestrian flow levels where pedestrian aspects are not justified, pedestrians still have the opportunity to cross streams of traffic which are halted. Wherever justified however, pedestrian aspects should be included to give a positive indication of when to cross.

4.2.8.4 Roundabouts are the least appropriate type of at-grade junction where pedestrians are concerned, unless the pedestrians are catered for on an exclusive segregated network. The flared approaches to roundabouts make the siting of crossing facilities difficult and it is often desirable to site the crossing some way back from the give way line where the carriageway width is less. Conventional roundabouts in particular cause designed pedestrian paths to be circuitous and unpopular, thus encouraging jaywalking. Zebra crossings can be compatible with roundabout design and should be considered.

4.2.8.5 At grade separated interchanges every effort should be made to include extensive grade separated pedestrian facilities. Footpaths attached to flyovers frequently represent an economical and effective method of providing grade separated pedestrian facilities. Care must be taken however that the resulting pedestrian routes are not so diverse as to be unattractive.

4.2.9 Choice of Junction Type

4.2.9.1 Many junction choices will be constrained by obvious economic, environmental and topographical considerations. The scope for weighty consideration of all the factors mentioned in the previous sections may therefore not be possible. However choice of junction type should encompass the examination of as many of these parameters as possible. To aid the designer Table 4.2.9.1 briefly summarises how each junction type performs against a list of the most important parameters. The table is perhaps of most use in comparing the signal and roundabout types of junction layout which can cater for a similar range of traffic flows.

4.2.9.2 In making the choice of junction type, it is also necessary to ensure consistency with the surrounding road network. An obvious example is that a roundabout which otherwise proves the most viable form of junction control when considered against other parameters, should be avoided in an area which is controlled by A.T.C. Similarly on high speed roads, traffic signals which require abrupt changes of speed should be avoided.

Table 4.2.9.1
Factors Affecting Choice of Junction Type

<u>Design Parameter</u>	<u>Priority Junction</u>	<u>Traffic Signal Junction</u>	<u>Roundabout Junction</u>	<u>Grade Separated Junction</u>
CAPACITY	Low - moderate flows	Moderate - high flows	Moderate - high flows	High flows
DELAY	At top end of flow range long delays experienced by minor road traffic	Adjacent junctions can be linked to minimise delay. However unnecessary delay unavoidable during most quiet hours even with minimum cycle time	Little delay if capacity not exceeded	No delay to major through traffic. Little or no delay to minor turning movements
SAFETY	Relies heavily on driver judgement and is susceptible to accidents at top end of flow range	Low right turn and pedestrian accident rate but may cause high rear end accident rate especially on high speed roads	Generally the safest form of at-grade junction over a wide range of flows and speeds	Some or all conflicting movements are removed with a consequent decrease in number of accidents. The few accidents which do occur may be severe owing to high speeds
ECONOMIC CONSIDERATIONS	Very low construction costs, but land take may be costly for larger physical island channelized junctions	Generally very cost effective. Cost of equipment is offset by reduction in land take	May be extravagant in terms of land take and consequently expensive. However check small and mini roundabout designs	Construction costs are high but these should be offset against reduction in community costs through fewer accidents, less delay etc. G.S.I.'s can also be economic users of land
PEDESTRIAN CONSIDERATIONS	Small simple junctions and those with physical channelisation may adequately cater for pedestrian demand. Shadow islands however should be avoided if pedestrian flow is heavy	Pedestrians can generally be catered for better at signals than at other at-grade junctions through positive indication	Pedestrian routes through roundabout junctions may be diverse and unattractive. Subways and/or footbridges should be considered for heavy pedestrian demand	Grade separated pedestrian facilities required

4.2.10 Spacing of Junctions

4.2.10.1 By limiting the number of junctions along a route the number of points of capacity reduction and high accident potential are similarly limited. Spacing of junctions should also have regard to such matters as the length needed for right turning, speed change lanes and weaving manoeuvres. It is recommended that the minimum spacing set out in Table 4.2.10.1 should be adopted and where practicable even greater distances should be used. For grade separated intersections longer spacing will often be dictated by the simple summation of the length of slip road and the merging, weaving and diverging requirements and it is unlikely that junction centres will be within 1 km of each other.

Table 4.2.10.1
Desirable Minimum Spacing between Junctions

<u>Route Type</u>	<u>Spacing(metres)</u>
Rural Trunk Roads	550
Urban Trunk Roads, Primary Distributors	300
District Distributors	200
Local Distributors	100

4.2.11 Signing and Lighting

4.2.11.1 The most elaborate and expensive junctions can be spoilt by poor signing and lighting and the provision of these ancillary facilities should receive consideration at an early stage in the design process. Badly located signs and lighting columns may impede visibility thereby reducing capacity and increasing accident potential. The designer should therefore have mind of the type and location of these facilities and ensure that his design provides space for their installation.

4.3 Priority Junctions

4.3.1 Introduction

4.3.1.1 Junctions which are controlled by stop or give way signs and/or markings are both the simplest and most numerous in the Territory. Priority control is most appropriately used at junctions where it is desirable to give continual priority to one route. The main advantage of this form of control is that little or no delay is experienced by the through traffic on the major route.

4.3.2 Types of Priority Junction

4.3.2.1 There are three types of priority junction appropriate to single carriageways viz simple, shadow island and physical island and they can be applied to three junction configurations viz crossroads, T-junctions and staggered junctions.

4.3.2.2 Simple junctions are those without any shadow or physical islands on the major road and without channelising islands in the minor road approach. They are appropriate for most accesses and minor junctions on single carriageways but are unsuitable for junctions with substantial minor road flows (see Diagram No. 4.2.3.1). Right turning traffic from the major road can be particularly problematic as there is no right turn diverging lane to prevent queues from delaying major road through traffic.

4.3.2.3 Shadow island junctions use a painted hatched island in the middle of single carriageway roads to provide a diverging lane and waiting space for vehicles turning right from the major road and thus overcome the problems mentioned in the previous paragraph. The same island, if wide enough, also offers protection to the right turn from the minor road thus allowing this traffic to complete its manoeuvre in two stages. It can be seen from Diagram No. 4.2.3.1, that even with relatively light major road flows the simple junction is only viable up to a minor road flow of about 500 vehicles 2 way AADT, and above this level a shadow island layout should be considered. Shadow islands are effective in improving safety, relatively cheap and should be considered for busy accesses and junctions on single carriageway roads.

4.3.2.4 Physical island layouts simply replace the painted central island described in the previous paragraph with a kerbed island, offering the same facility to the right turning traffic streams. Physical island layouts are more appropriate on higher speed roads, as the through lanes are physically restricted to cater for single file traffic thus discouraging overtaking through the junction. Physical islands may give the appearance of dual carriageway sections and appropriate signing should be erected to dispel this notion. In particular dual carriageway signs must not be erected at physical island layouts.

4.3.2.5 In addition to the three layouts described for single carriageways, priority junctions may also be appropriate for dual carriageway roads. Local widening of the central reserve provides sufficient width to harbour right turning traffic. Priority junctions on dual two lane roads are appropriate for minor road flows up to approximately 3000 vehicles AADT 2 way (N.B. much less than physical island layouts on single carriageway roads). On dual three lane roads priority control should never be used.

4.3.2.6 In terms of junction configuration the priority control is much more suited to T-junctions. The majority of roads in urban areas within the Territory however are priority controlled crossroads. They continue to operate satisfactorily only because of the low speeds involved. Generally, priority controlled crossroads in new junction design should only be considered for very low minor road flows. They should not be used on dual carriageways, single carriageways with physical islands and all new junctions in rural areas.

4.3.2.7 Wherever possible staggered junctions should be used in preference to crossroads. Right/left staggered are preferred to left/right staggers. Paragraph 4.3.13.1 contains recommendations on the design of staggered junctions.

4.3.3 Siting of Priority Junctions

- 4.3.3.1 Where possible it is preferable to site junctions on level ground or in sags rather than at or near the crest of hills. Drivers approaching a junction on an uphill gradient have difficulty in appreciating the junction layout whereas when they are approaching on a down gradient they have a good view of the situation ahead.
- 4.3.3.2 On curved sections of major roads, minor roads should be brought in on the outside of curves if possible. This is especially important on climbing lane sections or dual carriageways.
- 4.3.3.3 On single carriageways where overtaking opportunity is limited, care must be taken in siting shadow islands to avoid these sections being used for through route overtaking manoeuvres.
- 4.3.3.4 The number of junctions should be kept to a minimum by collecting lightly trafficked accesses into a service road which can form a single junction with the major road.

4.3.4 Safety at Priority Junctions

- 4.3.4.1 As stated in paragraph 4.2.6.1; in the United Kingdom 57% of all injury accidents occur at junctions. Just over half of these occur at priority junctions. It has been found that for the same major and minor road flows priority control almost invariably produces more accidents than other junction types and that the accidents are more serious. The accidents mainly involve right turning vehicles which feature in 90% of accidents, equally divided into right turns to and right turns from the major road.
- 4.3.4.2 Again using recent statistics from the United Kingdom certain junction improvements have been found to have the following effects : Installation of shadow islands on single carriageway roads has reduced accidents by about 40%. The replacement of rural crossroads by a staggered junction has reduced accidents by about 60%. The installation of deflection islands on the minor road approaches to rural crossroads has reduced accidents by about 50%. Other improvements which have been found to significantly reduce accidents include : restriction of turning movements, improvement to visibility, installation of guardrails and pedestrian refuges and the provision of skid resistant material. It is intended that more detailed advice on accidents at all junctions based on statistics collected in the Territory will be presented in Volume 5 - Accident Analysis & Prevention.

4.3.5 Pedestrian Facilities at Priority Junctions

- 4.3.5.1 Pedestrian requirements at priority junctions, as with other junction types, should be given equal weight to vehicular needs. The designer therefore needs to assess pedestrian loadings and develop his layout, from the beginning, to cater for these predicted flows. On single carriageway roads simple junctions and physical island junctions can cater for a reasonable volume of pedestrians but shadow islands may lead to a false sense of security for pedestrians and should be avoided. Priority junctions at dual carriageways also present difficulties for pedestrians owing to the width of carriageway to be crossed.
- 4.3.5.2 Crossings should normally be located close to the junction but far enough back that the crossing width is minimum. The set back should be sufficient to enable a vehicle to wait between the crossing and the stop/give way line. Pedestrians should be channeled to the correct crossing place, which may be of cautionary or zebra types, by the use of guardrailing.
- 4.3.5.3 Grade separated pedestrian crossings may provide an acceptable solution at some locations but the reluctance of pedestrians to use such facilities on roads which are not wide and heavily trafficked should be borne in mind.

4.3.6 Capacity of Priority Junctions

- 4.3.6.1 All priority junction layouts impose little or no delay to the through and left turning traffic streams on the major road and consequently no loss in capacity to cater for the non priority traffic streams, i.e. the right turn from the major road and both right and left turns from the minor road.
- 4.3.6.2 Capacity prediction for priority junctions in the past has been based on the theory of gap acceptance, in which vehicles in the non priority streams are assumed to move into naturally occurring gaps in the appropriate priority streams. The capacity was then calculated from a knowledge of minimum gaps acceptable to non priority drivers and the likely frequency of occurrence of such gaps. For various reasons this method has been found to be unsatisfactory and has been superseded.
- 4.3.6.3 Recent work has produced empirical formulae linking the capacity of the non priority traffic streams to the major road flows and the junction geometry. The formulae are based on multiple regression analyses from observations at a large number of sites in the United Kingdom. The viability of the junction layout is assessed by comparing the design flow of each non priority movement with the calculated capacity of that movement.
- 4.3.6.4 The parameters of junction geometry which have been found to exert the major influence on capacity of non priority movements are : major road width, width of central median, lane width available to waiting traffic streams and visibility distances for non priority traffic streams. These parameters are employed in the predictive equations. Other aspects of junction geometry notably, gradient, angle of intersection and radius of minor road vehicle path were found to have minimal influence on junction capacity and therefore do not appear in the equations.
- 4.3.6.5 In evaluating a proposed junction layout the design flow, arrived at as described in paragraph 4.2.4, should be compared with the calculated capacity to produce a design flow/capacity ratio (DFC) for each non priority movement. The capacity is the rate of discharge when there is saturation demand and therefore implies considerable queuing and vehicular delay. For design purposes a suitable margin is therefore required. A DFC of 85% would indicate a reasonable capacity provision which would prevent queuing in the majority (85%) of cases. A DFC of 70% would indicate that queuing would theoretically be avoided in nearly all (95% of) cases. Frequently the major road right turn would present more of a problem, if queuing occurred, than the minor road movements. This is because such a queue may reduce capacity on the straight through major road flow and has been found to detrimentally affect safety. A lower DFC may therefore be desirable on the major road right turn than on the minor road turning movements.
- 4.3.6.6 The predictive equations for priority junction capacity are given in Appendix 1 together with definitions of parameters, explanatory diagrams and a worked example of the manual application of the formulae. The manual computation of the formulae is very useful in preliminary design of priority junctions and should certainly be used in preference to formulae previously available for capacity calculation. This method is however best suited for computer application and the program PICADY will compute short term variations in flow to predict peak vehicular delays and queue lengths and optimise geometric parameters to minimise them. It is anticipated that the program will be available for use in Hong Kong in the near future.
- 4.3.6.7 The predictive equations given in Appendix 1 are applicable only to T-junctions and staggered crossroads which may be treated as two separate T-junctions.

4.3.7 General Layout Requirements

- 4.3.7.1 The layout should be designed to follow the natural vehicular paths. Unduly sharp radii or complex paths involving several changes of direction must be avoided. The general aim is to achieve a layout which is easily understood by motorists.

- 4.3.7.2 To achieve this objective, islands, traffic signs and road markings should be specifically designed to define the paths to be taken. Cutting, merging and diverging movements can usefully be separated by physical or painted islands. Numerous small traffic islands should however be avoided as they are ineffective and confusing.
- 4.3.7.3 Allowance should be made for the swept turning paths of long goods vehicles where they can be reasonably expected to use a junction. Consideration should also be given to the manoeuvring characteristics of these vehicles in the design of staggered junctions.
- 4.3.7.4 Specific aspects of the various geometric parameters which combine to produce a satisfactory layout are covered in the following sections. It should be remembered that the geometric standards suggested are ideals to be aimed at but should not be so rigidly applied that a junction becomes out of scale with its surroundings, environmentally damaging or exorbitantly expensive. Several of the standards are related to design speed. Where junction design refers to a new junction on an existing road or improvement to an existing junction the measured 85th percentile speed should be used, rounded up to the next highest design speed step. Where the design is concerned with a new road, the design speed of the road should be adopted. Suffixes A and B attached to design speeds are defined in Chapter 3, paragraph 3.3.2.3 as :

Design Speed A represents a high standard alignment with only occasional low radius curves and Design Speed B represents a heavily constrained alignment where low radius curves have been frequently adopted because of difficult topography or dense development.

4.3.8 Visibility Splays

- 4.3.8.1 Drivers approaching a priority junction from the minor road should have unobstructed visibility to the left and right along the major road, for a distance dependent on the major road traffic speed, to enable them to judge safely when they may turn into or cross the major road. This visibility also allows drivers on the major road to be aware of traffic entering from the minor road in time for them to be able to slow down or stop safely should this be necessary.
- 4.3.8.2 The visibility should be available between points 1.05m above the road level and provided by means of a visibility splay whose area is defined by lines joining the points A, B and C as shown in Diagram No. 4.3.8.1.
- 4.3.8.3 For roads within estates and other local roads of minor nature or experiencing low speeds the distance AC above relating to the 50 km/h design speed may be reduced to 50m.
- 4.3.8.4 In difficult situations the dimensions AB may be reduced to 4.5m and in exceptional circumstances 2m but the distance AC as recommended above should always be provided. If AB is greater than 15m high minor road approach speeds can be expected and this situation should receive special considerations. (The dimensions of lines AB and AC also govern the need for stop control as opposed to give way control and more information on this point is given in Volume 3 para. 2.3.2.4.)
- 4.3.8.5 Where the major road is a dual carriageway, with a central reserve of adequate width to shelter traffic turning right from the minor road, the visibility splay to the left should not be provided, but the central reserve should be clear of obstructions to the required distance as defined by dimension AC and as depicted in Diagram No. 4.3.8.2. Similarly if the major road is one way, only a splay in the direction of approaching traffic is required.

4.3.8.6

In the vast majority of urban situations low major road speeds are accompanied by wider footpaths. Additionally the high cost of lane and intensity of development would provide ample justification for the reduction of dimension AB to the 4.5m to 2m range. In such cases the required minimum distance AC would be provided without any corner splay being applied to adjacent buildings. In order to maintain adequate footpath widths in these situations corner splays should be provided in accordance with the standards set out in Diagram 4.3.8.3.

DIAGRAM 4.3.8.1 : VISIBILITY SPLAYS AT PRIORITY JUNCTIONS

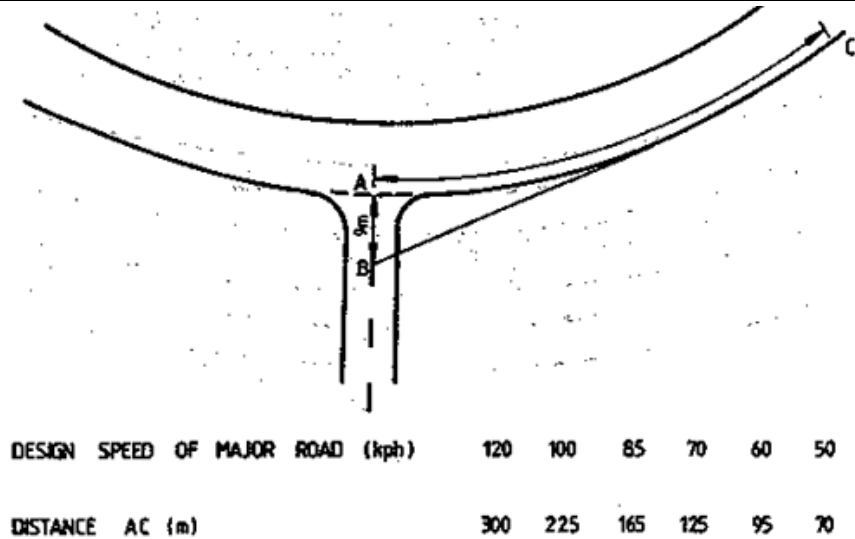

DIAGRAM 4.3.8.2 : VISIBILITY SPLAYS ON DUAL CARRIAGEWAYS

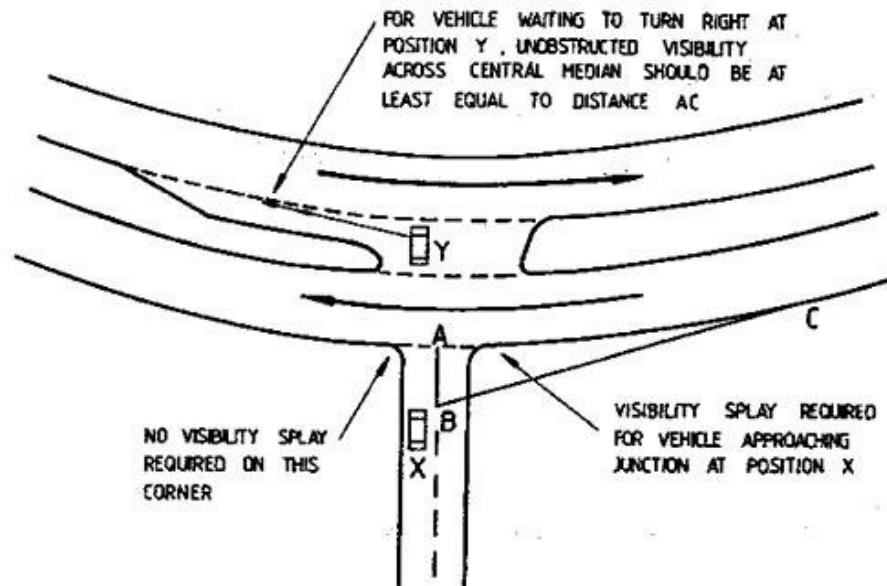
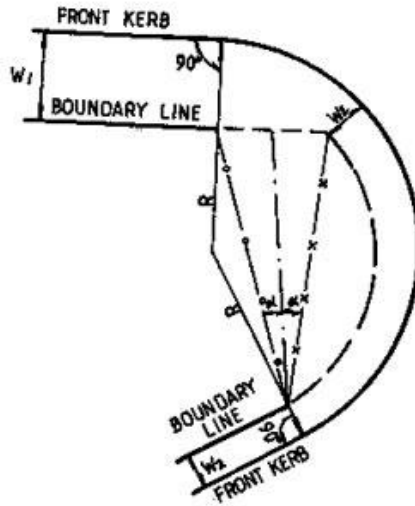
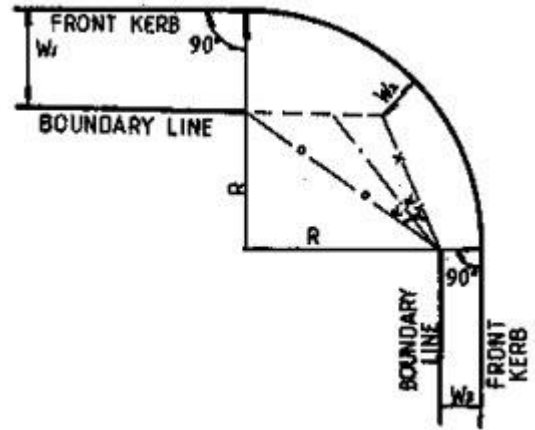

DIAGRAM 4.3.8.3A : STANDARD FOR CORNER SPLAYS

(1) ACUTE ANGLED INTERSECTIONS



(2) RIGHT ANGLED INTERSECTION



LEGEND

— • —	— x —	— • —
MAXIMUM SPLAY REQUIREMENT	MINIMUM SPLAY REQUIREMENT	RECOMMENDED SPLAY REQUIREMENT

- NOTE: (1) NO CORNER SPLAY IS RECOMMENDED WHEN 2 BOUNDARY LINES INTERSECT OUTSIDE THE SEGMENT ENCLOSED BY THE FRONT KERB RADII. SEE FIG.4
- (2) CONSIDERATION SHOULD BE GIVEN TO THE POSSIBLE FUTURE SITING OF PEDESTRIAN CROSSINGS

DIAGRAM 4.3.8.3B : STANDARD FOR CORNER SPLAYS

(3) OBTUSE ANGLED INTERSECTION

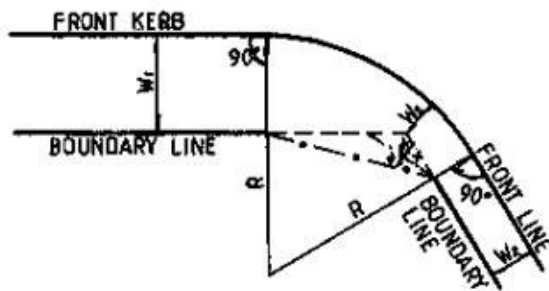

(4) NO ANGLE SPLAY TO BE PROVIDED

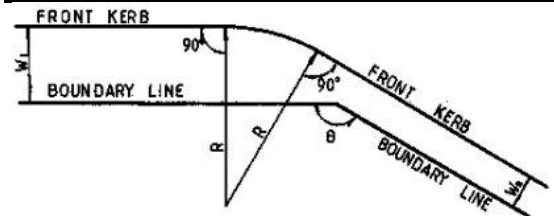

LEGEND

— • —	— x —	— • —
MAXIMUM SPLAY REQUIREMENT	MINIMUM SPLAY REQUIREMENT	RECOMMENDED SPLAY REQUIREMENT

- NOTE: (1) NO CORNER SPLAY IS RECOMMENDED WHEN 2 BOUNDARY LINES INTERSECT OUTSIDE THE SEGMENT ENCLOSED BY THE FRONT KERB RADII. SEE FIG.4
- (2) CONSIDERATION SHOULD BE GIVEN TO THE POSSIBLE FUTURE SITING OF PEDESTRIAN CROSSINGS

4.3.9 Right Turning Lanes

4.3.9.1 Right turning or offside diverging lanes aid vehicles turning right from the major road by allowing them to decelerate and if necessary wait before making the right turn manoeuvre. Through traffic on the major route also benefits by not being impeded by vehicles waiting to turn right, while right turning vehicles from the minor road can wait in the area provided and thus carry out their manoeuvre in two stages.

4.3.9.2 Right turning lanes should be provided at all priority junctions on dual carriageways and at those on single carriageways of the physical island or shadow island types of layout. The lane is made up of two components, a deceleration length and a turning length. The deceleration length is dependent on the design speed of the major road and the average gradient on the major road over a distance of 150m before the minor road. Deceleration lengths are shown in Table 4.3.9.1. The turning length is always 10m irrespective of junction type, design speed and gradient.

Table 4.3.9.1
Deceleration Lengths (m) of Right Turning Lanes

Design Speed (km/h)	Up Gradient		Down Gradient		
	0 - 4%	Above 4%	0 - 4%	Above 4%	
				(a)	(b)
100A	80	55	80	80	110
85A	55	40	55	55	80
70A	40	25	40	40	55
60A	25	25	25	25	40
50A	25	25	25	25	25

For above 4% down gradients (a) refers to shadow island and physical island single carriageway layouts while (b) refers to dual carriageway sites.

4.3.9.3 For dual carriageway and physical island type single carriageway junctions the width of the right turning lane should be 3.5m. It should be developed by means of a taper whose length will depend on the design speed. The length of the taper which is included as part of the total deceleration length given in Table 4.3.9.1 is as follows :

Design speed (km/h)	100	85	70	60	50
Length of taper (m)	25	15	15	5	5

4.3.9.4 For shadow islands the width of the right turning lane will vary but it should be an absolute minimum of 3m for new junctions and 2.5m for improvements to existing junctions. Where it is desirable to shelter vehicles turning right from the minor road, widths up to a maximum of 5m should be used. However, on high speed roads, widths greater than 3.5m should be avoided so as not to encourage overtaking. The right turning lane should be introduced by means of a 45 degree splay, at the end of the taper, except a left/right staggered junctions. At left/right staggered junctions the deceleration lengths will lie side by side and the starting points of the deceleration lengths should be joined by a straight line as in Diagram No. 4.3.16.10A & B.

4.3.9.5 At dual carriageway junctions and single carriageway junctions with physical islands the width of the central reserve will be made up of the 3.5m wide right turning lane plus the width of the physical median. With a minimum median width of 1.5m, a 5m wide central reserve will be formed. Whilst such a width would shelter small vehicles turning right from the minor road, it is recommended that the central reserve be locally widened to 10m if all but the longest vehicles are to be accommodated. This 10m would include the metre strips which, it is recommended, should be introduced locally if not present through the major route.

4.3.9.6 Central islands should normally be developed to their maximum widths symmetrically about the centre line of the major road at the tapers shown below :

Design speed (km/h)		100	85	70	60	50
Single carriageway taper (physical and shadow islands)	1 in	30	25	20	20	20
Dual carriageway tapers	1 in	50	45	40	40	40

It is perfectly acceptable to develop central islands asymmetrically however in order to avoid utilities for example, and in the case of climbing lanes or sections on sharp curves asymmetric development may be essential.

4.3.9.7 At physical island layouts on single carriageway roads central islands should be introduced by hatched markings until a width of 1.5m has been developed.

4.3.9.8 Adjacent to the right turning lanes are the through traffic lanes. At shadow island junctions the through lane should be between 3.0m and 3.65m wide (exclusive of hard strips if present). At physical islands on single lane carriageways the through lane should be 4.0m wide, which with two hard strips will allow through traffic to pass a broken down vehicle. At dual carriageway sites the through lane widths remote from the junction should be maintained through the junctions.

4.3.10 Left Turning Lanes (Diverging)

4.3.10.1 Nearside diverging lanes allow left turning major road traffic to slow down and leave the major road without impeding the following through traffic. They should be formed by a taper to a width of 3.5m contiguous to the corner into the minor road which should preferably be of radius 20m. The width of entry to the minor road will depend on this radius.

A typical layout is illustrated in Diagram No. 4.3.16.4.

4.3.10.2 Nearside diverging lanes should not be provided at simple priority junctions but should be provided at other priority junction types where the following conditions are met :

- (i) Design speed 80 km/h or above and left turning traffic greater than 600 vehicles AADT.
- (ii) Design speed 80 km/h or above and left turning traffic greater than 450 vehicles AADT with at least 20% heavy goods vehicles.
- (iii) At any design speed where gradient is greater than 4% and left turning traffic greater than 450 vehicles AADT.

However they should not be provided where the minor road is on the inside of a sharp curve as traffic on the diverging lane could adversely affect visibility for drivers emerging from the minor road.

- 4.3.10.3 The length of nearside diverging lane is defined as being from the beginning of the taper to the point of conflict with the major road right turning traffic. For design speeds of 70 km/h or less the length should be 35m. For design speeds greater than 70 km/h maximum and minimum lengths of diverging lane should be in accordance with Table 4.3.10.1.

Table 4.3.10.1
Maximum and (Minimum) Lengths of Nearside Diverging Lane

Design Speed (km/h)	Up Gradient		Down Gradient		
	0 - 4%	Above 4%	0 - 4%	Above 4%	
				(a)	(b)
100A	80 (40)	55 (35)	80 (40)	80 (40)	110 (55)
85A	55 (35)	40 (35)	55 (35)	55 (35)	80 (40)

(a) = shadow and physical island single carriageway sites

(b) = dual carriageway sites

4.3.11 Left Turning Lanes (Merging)

- 4.3.11.1 Merging lanes allow left turning minor road traffic to accelerate before joining the major road traffic. They are normally only appropriate at dual carriageway junctions where the design speed of the major road is 80 km/h or above and the volume of left turning minor road traffic exceeds 600 vehicles AADT. The flow figure may be reduced to 450 vehicles AADT where there is an up gradient exceeding 4% or where the percentage of heavy goods vehicles exceeds 20%. Merging lanes should never be used at single carriageway physical island layouts.

- 4.3.11.2 A separate turning lane, preferably of radius 25m, should be used to introduce the merging lane from the minor road. The initial width of the lane, which will depend upon the radius of the turning lane, should be decreased at a constant taper of 1 in 15. This taper should be introduced relative to the perpendicular to the minor road centre line at its point of entry to the major road, not relative to the major road centre line. A left turn merging lane is shown in Diagram No. 4.3.16.5.

4.3.12 Traffic Islands and Refuges

- 4.3.12.1 Section 4.3.9 has already considered in some detail the layout of the traffic island or central reservation associated with right turning lanes. This section looks at some general points affecting islands and refuges and more specific points concerning minor road channelising islands.

- 4.3.12.2 Traffic islands are provided at priority junctions for a variety of reasons viz : to give guidance on intended vehicular paths, to channelise intersecting or merging traffic, to warn drivers of the impending junction, to provide shelter for vehicles carrying out certain manoeuvres and to assist pedestrians.

- 4.3.12.3 Islands should have a minimum area of 4.5 sq.m. Smaller islands should be defined by road markings only. The approach nose should be offset to reduce the risk of vehicles overriding the island and colliding with the illuminated bollard which should be located at its apex.

- 4.3.12.4 Where a traffic island serves as a pedestrian refuge it should be at least 1.25m wide and have openings in the centre at carriageway level to facilitate pedestrians crossing. Kerbs, opposite the refuge, should be dropped locally. Care should be taken to ensure that visibility between motorist and pedestrian is not obstructed by street furniture.

- 4.3.12.5 The recommended layouts for minor road channelising islands are shown in Diagram No. 4.3.16.15 and details of their design are discussed in Section 4.3.16.

4.3.13 Stagger Distances

4.3.13.1

It is important at staggered junctions that a minimum spacing be achieved between the two side roads in order to provide for satisfactory manoeuvring of large vehicles. The following stagger distances will cater for the longest articulated vehicle using the Territory's roads :

Minimum stagger distances (m)
between centre lines of minor roads

<u>Type of Junction</u>	<u>Right/Left Stagger</u>	<u>Left/Right Stagger</u>
Simple	50	50
Shadow Island	40	50*
Physical Island	50	60*
Dual Carriageway	60	60*

The left/right stagger values marked with an asterisk, although representing the minimum distances for long vehicle manoeuvring, should in fact be increased for higher design speeds. This is because at left/right staggered junctions the right turning lanes lie side by side and their combined length is greater than the minimum length required for vehicle manoeuvring. Left right stagger distances at all but simple junctions are therefore governed by design speeds as follows :

Design Speed (km/h)	70	85	100
Stagger Distance	60	75	100

These figures will also vary with major road gradient as described in paragraph 4.3.9.2.

4.3.14 **Corner Radii**

4.3.14.1

The corner radii on the layouts shown on Diagram Nos. 4.3.16.1 to 4.3.16.14 inclusive have been designed to cater for a 16.0m long articulated vehicle with a single axle at the rear of the trailer. At some simple junctions where the design vehicle will encroach into opposing traffic lanes, this fact is annotated on the relevant layout.

4.3.14.2

At some junctions it may be decided that it is not necessary to cater for such a long vehicle and a different design vehicle may be chosen. The turning requirements of this design vehicle will then dictate the corner radii required. The increasing use of 12m buses in the Territory should not be overlooked in the design of corner radii and at perpendicularly intersecting roads a 12m corner radius is required for this type of vehicle.

4.3.14.3

Where long vehicles are catered for by the use of corner radii and flares the designer should be aware of the potential problems resulting from smaller vehicles using the widened approaches for multiple entry.

4.3.14.4

In cases where no allowance is to be made for long vehicles it is recommended that the absolute minimum circular corner radii should be 6m in urban areas and 9m in rural areas.

4.3.15 **Widths of Carriageways in Junctions**

4.3.15.1

Where carriageways at junctions go round low radius corners widening should be provided to cater for the swept path of long vehicles. Also, at physical island layouts, with single carriageways greater than 50m in length, an allowance should be made for broken down vehicles.

4.3.15.2

Table 4.3.15.1 shows recommended widths of carriageway corresponding to various near side corner radii. The recommendations for Single Lane Width are based on the requirements of a 16.0m long articulated vehicle. The recommendations for single lane width to pass stationary vehicle are subdivided into three standards. The 6m effective width column should be considered as the normal standard and would allow any vehicle to pass any other vehicle. Reduced standards may be considered appropriate and the 5.2m effective width column will provide sufficient space for a goods vehicle to pass a stationary car but not for a goods vehicle to pass another goods vehicle or bus. Similarly, whilst the 4.3m effective width will allow a car to pass another stationary car it is unlikely that a goods vehicle or bus would be able to pass a stationary car. The two lane width for one way or two way traffic columns represent two standards. The normal minimum column would allow operation of the 16m articulated vehicle while the absolute minimum column represents a reduced standard which should not be used on bus routes or in situations with more than the minimum volumes of medium and heavy goods vehicles.

Table 4.3.15.1
Width of Carriageways in Junctions

Inside Corner Radius (m)	Single Lane Width (m)	Single lane Width with Space to Pass Stationary Vehicle Including Hardstrip Provision (m)			Two Lane Width for One Way or Two Way Traffic (m)	
		Effective Width 6m	Effective Width 5.2m	Effective Width 4.3m	Normal Minimum	Absolute Minimum
10	8.4	10.9	9.5	8.4	14.9	9.5
15	7.1	9.6	8.2	7.1	13.1	9.0
20	6.2	8.7	7.3	6.2	11.8	8.7
25	5.7	8.2	6.8	5.7	10.9	8.5
30	5.3	7.8	6.4	5.3	10.3	8.2
40	4.7	7.2	5.8	4.7	9.3	7.9
50	4.4	6.9	5.4	4.3	8.7	7.7
75	4.0	6.5	5.2	4.3	8.0	7.4
100	3.8	6.3	5.2	4.3	7.6	7.3
150	3.65	6.0	5.2	4.3	7.3	7.0

Widths are exclusive of hardstrips, where present, except for single lane width to pass broken down vehicles. For explanation of various columns see paragraph 4.3.15.2.

4.3.16 Recommended Layouts

4.3.16.1

Based on the foregoing sections, Diagram Nos. 4.3.16.1 to 4.3.16.14 have been prepared to show how the individual elements are combined to produce typical junction layouts. It should be stressed (again) that the junction layouts are targets for which the designer should aim. Lesser provision may well be justified for reasons of land take, topography, environmental considerations or cost. However as many elements of the design as possible should be incorporated.

4.3.16.2

It should also be noted that the layouts can all cater for the design vehicle which is a 16.0m long articulated vehicle with single rear axle. Although many of the design elements are not related to vehicular turning properties, some, such as corner radii, are and may be adjusted to suit a preferred design vehicle.

4.3.16.3

Particular comments on the typical junction layouts are as follows :-

Diagram No. 4.3.16.1

This shows suggested treatments for urban and rural simple T-junctions. The encroachment of long vehicles is annotated for each layout. It should be stressed that the layouts shown are only examples of kerb treatment. If land constraints do not permit the use of the prescribed kerb layouts alternative combinations of radii and straight should be tested to suit both the particular land constraints and the swept path and turning radii of the design vehicle for that junction. For example it may be decided that the most onerous vehicle which will use a junction will be a 12m bus and the operating characteristics of this vehicle should then be used for design.

When using the urban layout catering for long vehicles particular care should be taken in the treatment of pedestrians. The designer should also be aware of potential problems from multiple entry of small vehicles using the flared section.

For the rural junction layouts the metre hardstrips can be introduced locally, if not existing throughout the route; and in such cases the hardstrip on the side of the major road which is remote from the minor road is not required.

Diagram No. 4.3.16.2

This shows a 7.3m wide single two lane carriageway with a 3.5m wide shadow island and could be suitable for rural or semi urban situations. This basic layout is adaptable for roads with metre strips and particularly suitable for 10m wide main carriageways where no widening is required. Where widening is required it can be introduced a symmetrically to avoid utilities for example.

If a pedestrian crossing is required the shadow island should not be used as a central refuge.

Diagram No. 4.3.16.3

This shows a 7.3m wide single two lane carriageway with 5m wide shadow islands and a two lane approach on the minor road. This layout is appropriate to a more heavily trafficked situation than the 3.5m wide islands. However shadow islands with widths greater than 3.5m should not be used on roads with design speeds above 80 km/h.

If a pedestrian crossing is required the shadow island should not be used as a central refuge.

Diagram No. 4.3.16.4

This shows a 10m wide physical island on a single 2 lane road, appropriate to a busy rural junction. The 10m island (including metre strips) is capable of sheltering most vehicles turning right from the minor road. This type of layout (also depicted in Drawings 4.3.16.5, 11 and 12) requires a certain amount of judgement and caution to be exercised by the conflicting right turning traffic movements.

A diverging lane is also shown and would be incorporated if the left turn flow into the minor road was heavy.

Diagram No. 4.3.16.5

This shows a T-junction on a dual two lane carriageway with 10m central reserve and merging lane. It is appropriate with a heavy left turn from the minor road and heavy right turns.

Diagram No. 4.3.16.6

This shows two possible layouts for urban crossroads with the encroachment of long goods vehicles annotated on each. As stated for Layout 1 the kerb treatments are only examples. For new junctions cross roads are only acceptable for low minor road flows.

Diagram No. 4.3.16.7

This shows two possible layouts for rural crossroads. Crossroads should be avoided for new construction in rural areas and the layouts are presented for improvement to existing junctions. The hardstrips should be introduced locally to emphasise the junction if not already present on the route.

Diagram No. 4.3.16.8

This shows an urban crossroads with a 3.5m shadow island. One minor road has a two lane approach and the other a one lane approach. This layout is not recommended for new construction but for existing junction improvement. Shadow islands should not be used at crossroads in rural areas.

If a pedestrian crossing is required the shadow islands should not be used as a central refuge.

Diagram No. 4.3.16.9

For new junctions staggered crossroads are far more preferable to straight crossroads. This layout shows a simple right left stagger suitable for urban or rural roads.

Diagram No. 4.3.16.10

This shows right/left and left/right staggers suitable for urban situations. In particular the right left stagger should not be used at high design speeds as it has been found that it encourages injudicious overtaking. The staggers shown are based on the manoeuvring requirements of a long vehicle. Staggered junctions are always to be preferred to straight crossroads and right/left staggers are preferable to left/right staggers.

If a pedestrian crossing is required the shadow islands should not be used as a central refuge.

Diagram No. 4.3.16.11

This shows a right/left stagger drawn for a higher design speed and more suitable for a rural situation. Indiscriminate overtaking is prevented by the use of physical islands.

Diagram No. 4.3.16.12

This shows the corresponding left/right stagger for the rural situation. The main carriageway is 7.3m wide as opposed to 10m wide in Diagram No. 4.3.16.11.

Diagram No. 4.3.16.13

This shows a T-junction situation on a rural climbing lane section with minor road on the right of the up gradient. Shadow islands should not exceed 3.5m in width on climbing lane sections.

If a pedestrian crossing is required the shadow islands should not be used as a central refuge.

Diagram No. 4.3.16.14

This shows two shadow island layouts for handling right hand and left hand splays. The layouts are a target for the designer to aim at and it is envisaged that a compromise arrangement may be necessitated on land take considerations. The layouts are intended for improvements to existing junctions rather than new junctions which should not be designed on a skew. Care should be taken that the left turn into the major road on the right hand splay junction is not so easy as to encourage merging.

If a pedestrian crossing is required the shadow islands should not be used as a central refuge.

Diagram No. 4.3.16.15

This shows the detailed design of the minor road channelising islands applicable to many of the preceding junction layouts. The design procedure stipulated for rural road channelising islands, although fairly straight-forward would need to be simplified for on-site setting out. It is suggested therefore that the detailed design procedure is followed and then the geometry simplified to facilitate setting out whilst still maintaining closely the designed shape. It is felt that such a procedure is preferable to simplifying the actual design steps which may lead to islands of unusual and may be unacceptable shape.

4.3.16.4

It will be noted from the drawing that rural channelising islands are divided into T-junctions and crossroads and the following points should be noted concerning each :

T-junctions (layout (a))

- (i) R, is tangential to the offset, d, from the minor road centre line and the offside edge of the through traffic lane on the major road into which right turning traffic from the minor road will turn.
- (ii) Point A is established by describing an arc of radius $R1 + 2$ concentric with R1 and joining its centre with the point on its circumference, where it crosses the edge of the major road carriageway, with a straight line. A is the point where this straight line crosses the arc R1.
- (iii) The circular arc R2 is tangential to the offside edge of the major road offside diverging lane and also passes through point A.
- (iv) For splay junction the centre line of the minor road is turned with a radius of at least 50m to meet the edge of the major road at right angles, and the island should be about 15m long.
- (v) For left hand splay junctions the offset d is 4.5m.

Crossroads (layout (b))

There are similarities with the design described under (a) but the following points should be noted :

- (i) The long axis of the island is inclined at 5 degrees to the minor road centre line and the island is always 3m wide.
- (ii) The circular arc R1 has a radius of 11m and is tangential to the left hand side of the island (viewed from the minor road approach) and the centre line of the major road. (In some cases where the minor road is inclined to the major road at angles between 100 degrees and 110 degrees R1 will have to be reduced to 8m to create a suitable island.)
- (iii) The circular arc R2 has a radius of 11m and is tangential to the major road centre line and the minor road centre line.
- (iv) Where the minor road centre line is inclined to the major road at angles less than 70 degrees R1 will normally be 12m and R2 8m.
- (v) Where the minor road centre line is inclined to the major road at angles greater than 110 degrees R1 will normally be 8m and R2 12m.
- (vi) Where two splay minor roads meet at a crossroad the minor road centre lines should be offset relative to one another by approximately the width of one island.

DIAGRAM 4.3.16.1 : SIMPLE T-JUNCTION

ALL DIMENSIONS ARE IN METRES.

URBAN - PROVIDED WHERE LONG VEHICLES ARE PREDICTED

(LONG COMMERCIAL VEHICLES ENCROACH INTO OPPOSING TRAFFIC LANES OF THE MINOR ROAD WHEN TURNING FROM THE MAJOR ROAD)

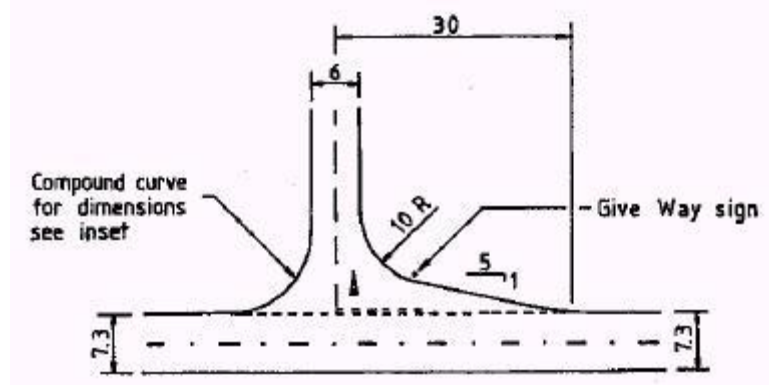

URBAN - STANDARD LAYOUT

(LONG COMMERCIAL VEHICLES REQUIRES THE FULL WIDTH OF THE MINOR ROAD WHEN TURNING FROM THE MAJOR ROAD AND ENCROACH INTO THE OPPOSING TRAFFIC LANE OF THE MAJOR ROAD WHEN TURNING FROM THE MINOR ROAD)

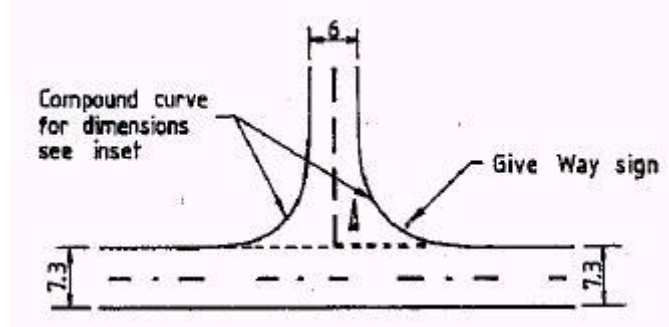

RURAL - PROVIDED WHERE LONG VEHICLES ARE PREDICTED

(NO ENCROACHMENT INTO OPPOSING TRAFFIC LANES FOR ALL MOVEMENTS)

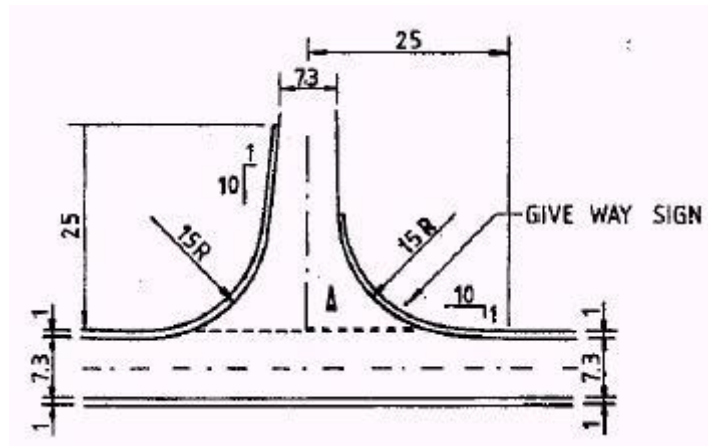

RURAL - STANDARD LAYOUT

(LONG COMMERCIAL VEHICLES ENCROACH INTO THE OPPOSING TRAFFIC LANE OF THE MINOR ROAD WHEN TURNING FROM THE MAJOR ROAD AND TRACK INTO OPPOSING LANE OF MAJOR ROAD WHEN TURNING FROM THE MINOR ROAD)

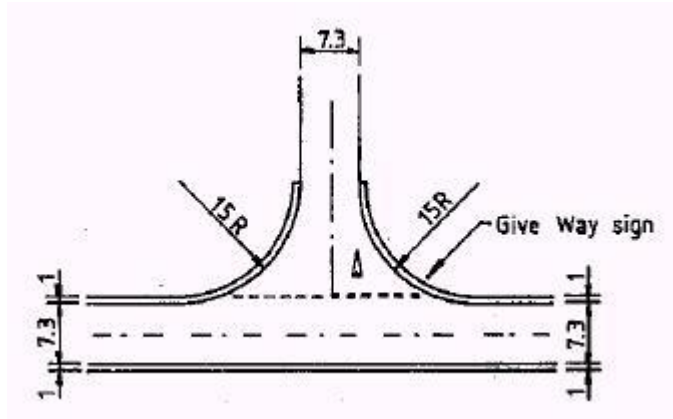

COMPOUND CURVE DESIGN

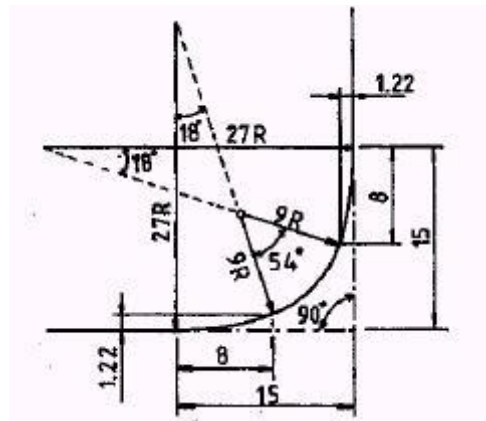

**DIAGRAM 4.3.16.2 : SINGLE 7.3m / SHADOW ISLAND 3.5m
DRAWN FOR 85A km/h DESIGN SPEED**

ALL DIMENSIONS ARE IN METRES.

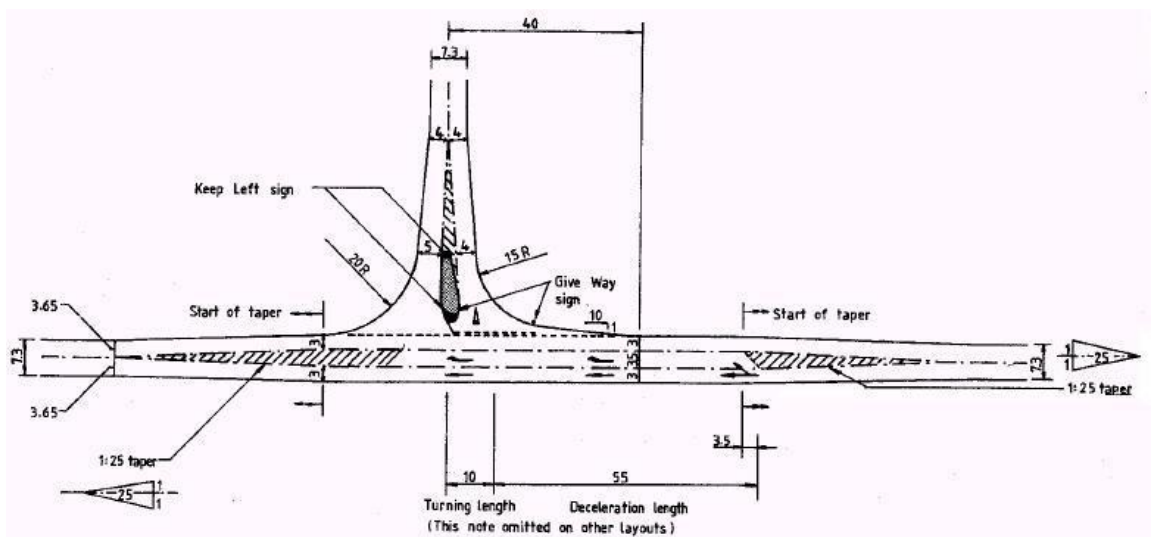

**DIAGRAM 4.3.16.3 : SINGLE 7.3m / SHADOW ISLAND 5m
DRAWN FOR 50 / 60 km/h DESIGN SPEED**

ALL DIMENSIONS ARE IN METRES.

SHOWING TWO LANE APPROACH ON MAJOR ROAD

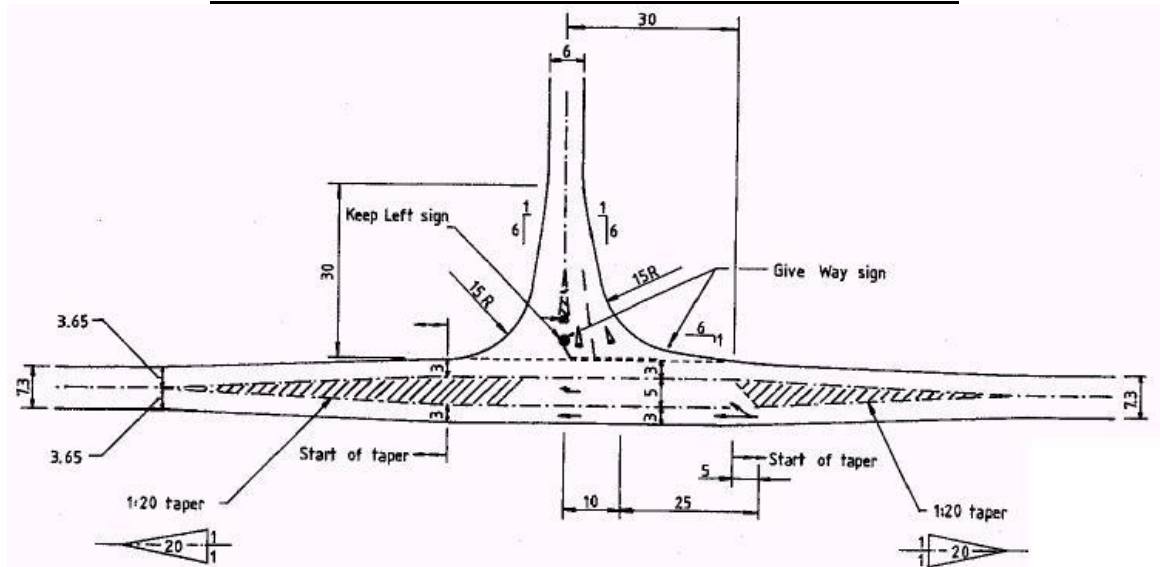

- NOTES:
1. DIAGRAMS DEPICT TYPICAL LAYOUTS UTILISING VARIOUS COMBINATIONS OF GEOMETRIC ELEMENTS. HOWEVER NOT ALL COMBINATIONS HAVE BEEN EXHAUSTED AND ELEMENTS MAY BE EXTRACTED FROM COMPATIBLE DIAGRAM TO FORM A NEW COMPOSITE LAYOUT.
 2. LAYOUTS HAVE BEEN DESIGNED TO CATER FOR A 16m ARTICULATED VEHICLE UNLESS OTHERWISE STATED. DESIGN BASED ON A LESS ONEROUS DESIGN VEHICLE MAY BE JUSTIFIED AND GEOMETRIC ELEMENTS REDUCED ACCORDINGLY.
 3. DEPENDING ON PEDESTRIAN VOLUMES, LAYOUT MAY NEED AMENDMENT TO ACCOMODATE AT GRADE PEDESTRIAN CROSSING.

**DIAGRAM 4.3.16.4 : SINGLE 7.3m / PHYSICAL ISLAND 10m
DRAWN FOR 85A km/h DESIGN SPEED
(INCLUDING DIVERGING LANE)**

ALL DIMENSIONS ARE IN METRES.

SHOWING SINGLE LANE APPROACH ON MINOR ROAD

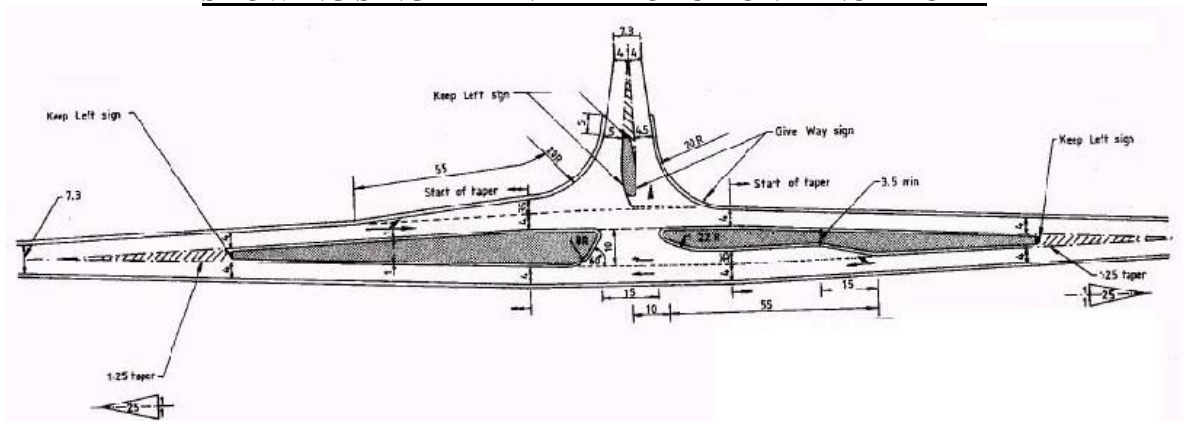

- NOTES:
1. DIAGRAMS DEPICT TYPICAL LAYOUTS UTILISING VARIOUS COMBINATIONS OF GEOMETRIC ELEMENTS. HOWEVER NOT ALL COMBINATIONS HAVE BEEN EXHAUSTED AND ELEMENTS MAY BE EXTRACTED FROM COMPATIBLE DIAGRAMMS TO FORM A NEW COMPOSITE LAYOUT.
 2. LAYOUTS HAVE BEEN DESIGNED TO CATER FOR A 16m ARTICULATED VEHICLE UNLESS OTHERWISE STATED. DESIGN BASED ON A LESS ONEROUS DESIGN VEHICLE MAY BE JUSTIFIED AND GEOMETRIC ELEMENTS REDUCED ACCORDINGLY.
 3. DEPENDING ON PEDESTRIAN VOLUMES, LAYOUT MAY NEED AMENDMENT TO ACCOMODATE AT GRADE PEDESTRIAN CROSSING.

DIAGRAM 4.3.16.5 : DUAL CARRIAGEWAY WITH 10m PHYSICAL ISLAND
SHOWING MERGING LANE - DRAWN TO 85A km/h DESIGN SPEED

ALL DIMENSIONS ARE IN METRES.

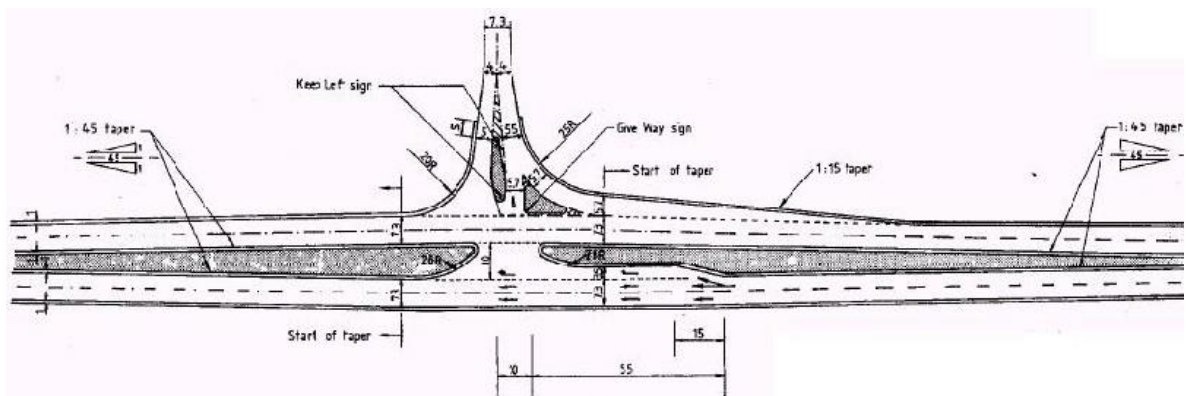

- NOTES:
1. DIAGRAMS DEPICT TYPICAL LAYOUTS UTILISING VARIOUS COMBINATIONS OF GEOMETRIC ELEMENTS. HOWEVER NOT ALL COMBINATIONS HAVE BEEN EXHAUSTED AND ELEMENTS MAY BE EXTRACTED FROM COMPATIBLE DIAGRAMMS TO FORM A NEW COMPOSITE LAYOUT.
 2. LAYOUTS HAVE BEEN DESIGNED TO CATER FOR A 16m ARTICULATED VEHICLE UNLESS OTHERWISE STATED. DESIGN BASED ON A LESS ONEROUS DESIGN VEHICLE MAY BE JUSTIFIED AND GEOMETRIC ELEMENTS REDUCED ACCORDINGLY.
 3. DEPENDING ON PEDESTRIAN VOLUMES, LAYOUT MAY NEED AMENDMENT TO ACCOMODATE AT GRADE PEDESTRIAN CROSSING.

DIAGRAM 4.3.16.6 : URBAN SIMPLE CROSSROADS

ALL DIMENSIONS ARE IN METRES.

STANDARD LAYOUT

(LONG COMMERCIAL VEHICLES REQUIRES THE FULL WIDTH OF THE MINOR ROAD WHEN TURNING FROM THE MAJOR ROAD AND ENCROACH INTO THE OPPOSING TRAFFIC LANE OF THE MAJOR ROAD WHEN TURNING FROM THE MINOR ROAD)

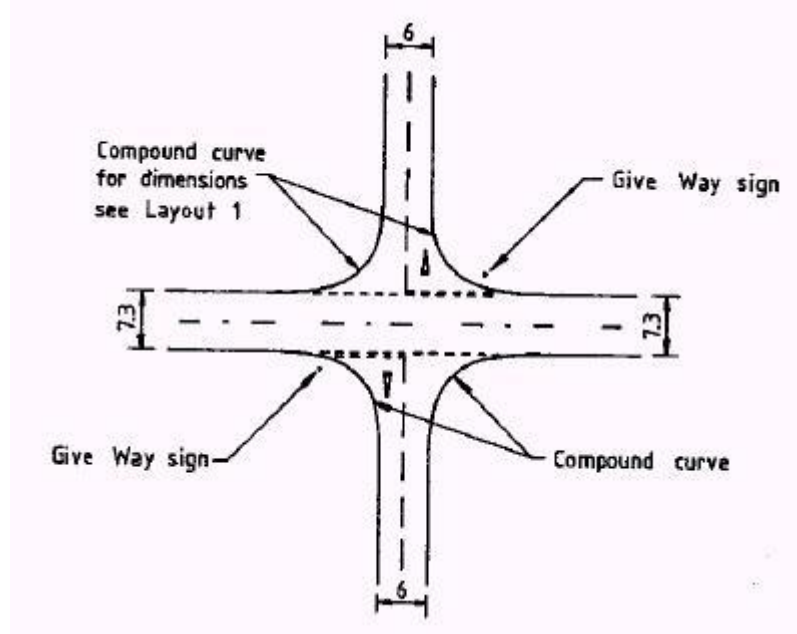

PROVIDED WHERE LONG VEHICLES ARE PREDICTED

(LONG COMMERCIAL VEHICLES REQUIRES THE FULL WIDTH OF THE MINOR ROAD WHEN TURNING FROM THE MAJOR ROAD)

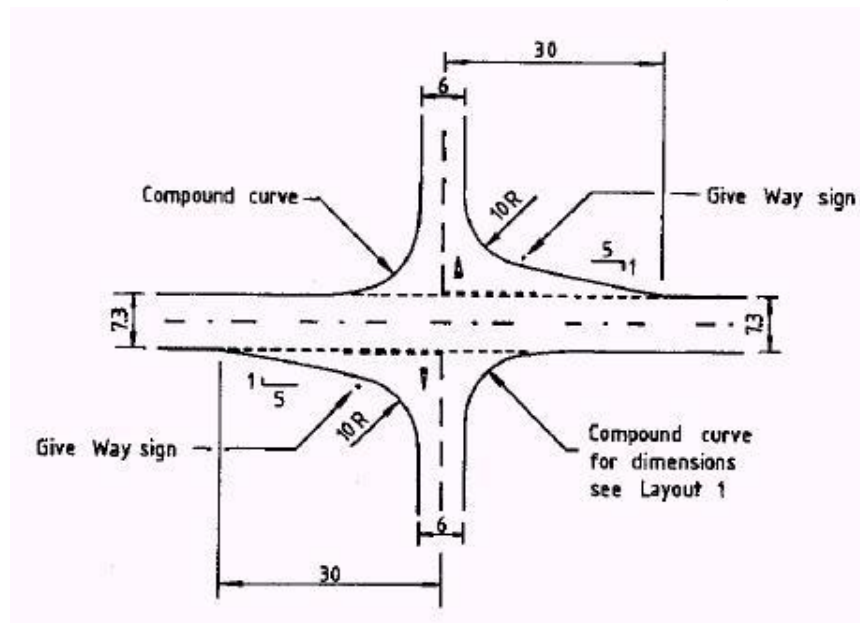

- NOTES:
1. DIAGRAMS DEPICT TYPICAL LAYOUTS UTILISING VARIOUS COMBINATIONS OF GEOMETRIC ELEMENTS. HOWEVER NOT ALL COMBINATIONS HAVE BEEN EXHAUSTED AND ELEMENTS MAY BE EXTRACTED FROM COMPATIBLE DIAGRAMMS TO FORM A NEW COMPOSITE LAYOUT.
 2. LAYOUTS HAVE BEEN DESIGNED TO CATER FOR A 16m ARTICULATED VEHICLE UNLESS OTHERWISE STATED. DESIGN BASED ON A LESS ONEROUS DESIGN VEHICLE MAY BE JUSTIFIED AND GEOMETRIC ELEMENTS REDUCED ACCORDINGLY.
 3. DEPENDING ON PEDESTRIAN VOLUMES, LAYOUT MAY NEED AMENDMENT TO ACCOMODATE AT GRADE PEDESTRIAN CROSSING.

DIAGRAM 4.3.16.7 : RURAL SIMPLE CROSSROADS

ALL DIMENSIONS ARE IN METRES.

PROVIDED WHERE LONG VEHICLES ARE PREDICTED

(NO ENCROACHMENT INTO OPPOSING TRAFFIC LANES FOR ALL VEHICLE MOVEMENTS)

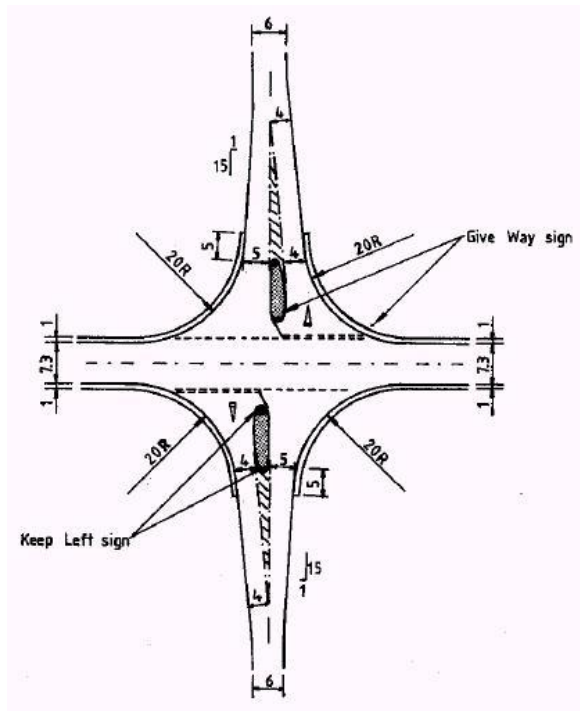

STANDARD LAYOUT

(LONG COMMERCIAL VEHICLES ENCROACH INTO OPPOSING TRAFFIC LANES WHEN TURNING INTO THE MAJOR ROAD AND THE MINOR ROAD)

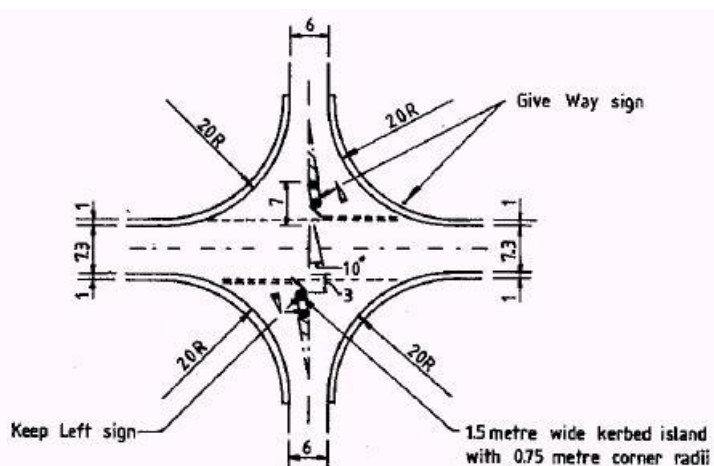
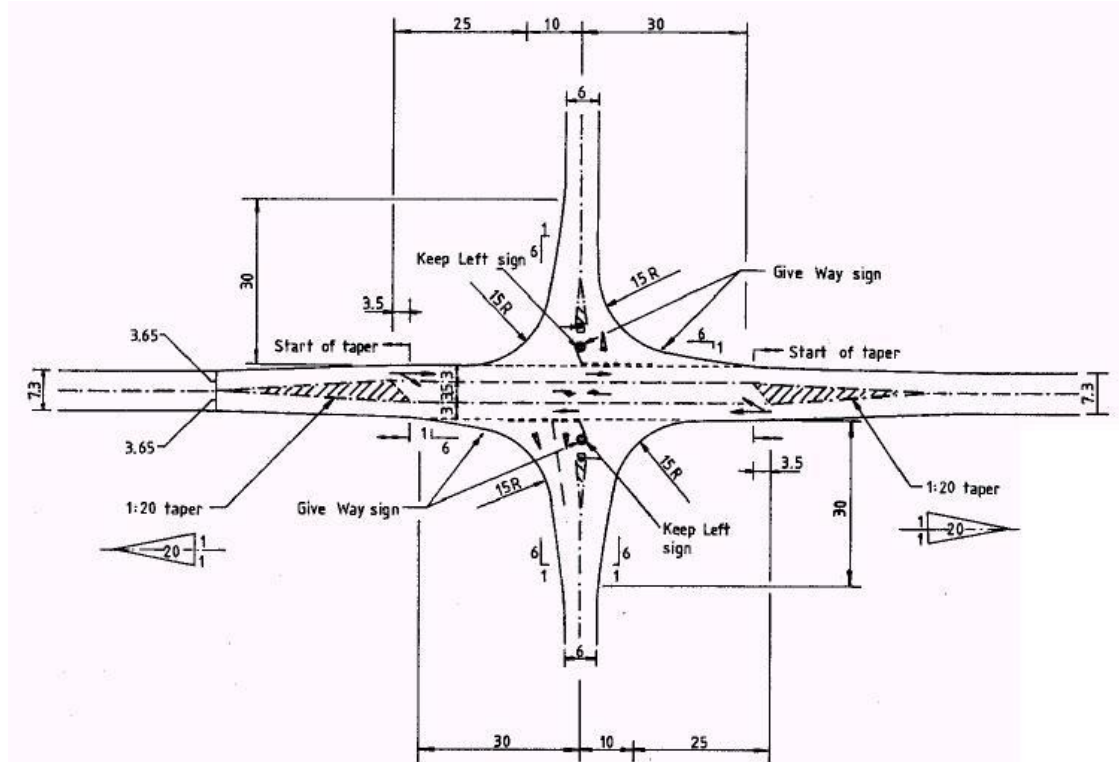

DIAGRAM 4.3.16.8 : URBAN CROSSROADS WITH SHADOW ISLANDS

ALL DIMENSIONS ARE IN METRES.



- NOTES:
1. DIAGRAMS DEPICT TYPICAL LAYOUTS UTILISING VARIOUS COMBINATIONS OF GEOMETRIC ELEMENTS. HOWEVER NOT ALL COMBINATIONS HAVE BEEN EXHAUSTED AND ELEMENTS MAY BE EXTRACTED FROM COMPATIBLE DIAGRAM TO FORM A NEW COMPOSITE LAYOUT.
 2. LAYOUTS HAVE BEEN DESIGNED TO CATER FOR A 16m ARTICULATED VEHICLE UNLESS OTHERWISE STATED. DESIGN BASED ON A LESS ONEROUS DESIGN VEHICLE MAY BE JUSTIFIED AND GEOMETRIC ELEMENTS REDUCED ACCORDINGLY.
 3. DEPENDING ON PEDESTRIAN VOLUMES, LAYOUT MAY NEED AMENDMENT TO ACCOMODATE AT GRADE PEDESTRIAN CROSSING.

DIAGRAM 4.3.16.9 : SIMPLE RIGHT/LEFT STAGGER

(LONG COMMERCIAL VEHICLES REQUIRE THE FULL WIDTH OF THE MINOR ROAD WHEN TURNING FROM THE MAJOR ROAD)

ALL DIMENSIONS ARE IN METRES.

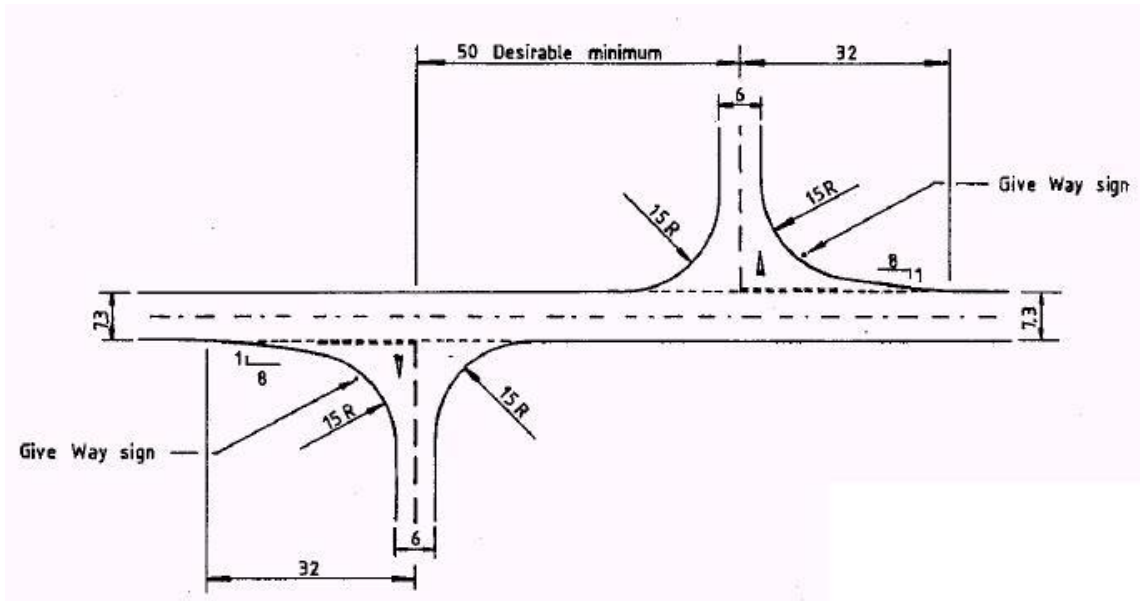

- NOTES:
1. DIAGRAMS DEPICT TYPICAL LAYOUTS UTILISING VARIOUS COMBINATIONS OF GEOMETRIC ELEMENTS. HOWEVER NOT ALL COMBINATIONS HAVE BEEN EXHAUSTED AND ELEMENTS MAY BE EXTRACTED FROM COMPATIBLE DIAGRAM TO FORM A NEW COMPOSITE LAYOUT.
 2. LAYOUTS HAVE BEEN DESIGNED TO CATER FOR A 16m ARTICULATED VEHICLE UNLESS OTHERWISE STATED. DESIGN BASED ON A LESS ONEROUS DESIGN VEHICLE MAY BE JUSTIFIED AND GEOMETRIC ELEMENTS REDUCED ACCORDINGLY.
 3. DEPENDING ON PEDESTRIAN VOLUMES, LAYOUT MAY NEED AMENDMENT TO ACCOMODATE AT GRADE PEDESTRIAN CROSSING.

**DIAGRAM 4.3.16.10A : URBAN RIGHT / LEFT AND LEFT / RIGHT STAGGERS
SINGLE 7.3m WITH 3.5m SHADOW ISLAND**

ALL DIMENSIONS ARE IN METRES.

RIGHT / LEFT STAGGER

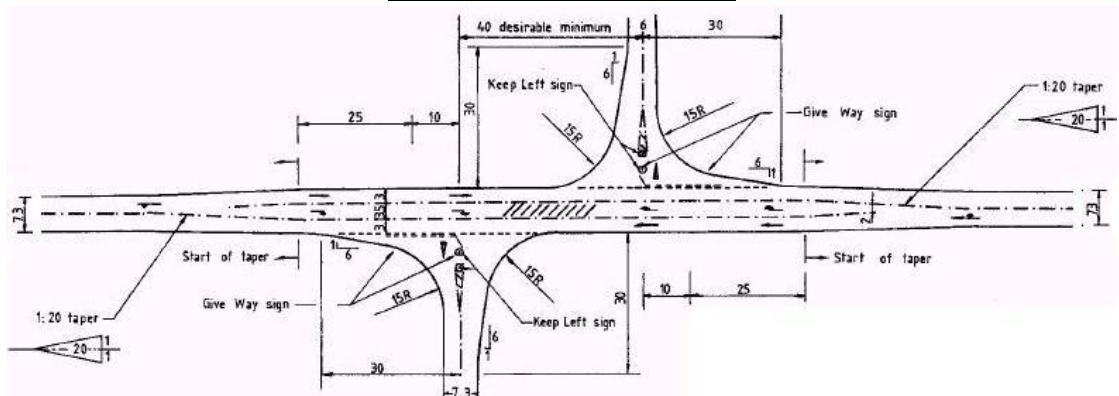

- NOTES:
1. DIAGRAMS DEPICT TYPICAL LAYOUTS UTILISING VARIOUS COMBINATIONS OF GEOMETRIC ELEMENTS. HOWEVER NOT ALL COMBINATIONS HAVE BEEN EXHAUSTED AND ELEMENTS MAY BE EXTRACTED FROM COMPATIBLE DIAGRAMMS TO FORM A NEW COMPOSITE LAYOUT.
 2. LAYOUTS HAVE BEEN DESIGNED TO CATER FOR A 16m ARTICULATED VEHICLE UNLESS OTHERWISE STATED. DESIGN BASED ON A LESS ONEROUS DESIGN VEHICLE MAY BE JUSTIFIED AND GEOMETRIC ELEMENTS REDUCED ACCORDINGLY.
 3. DEPENDING ON PEDESTRIAN VOLUMES, LAYOUT MAY NEED AMENDMENT TO ACCOMODATE AT GRADE PEDESTRIAN CROSSING.

DIAGRAM 4.3.16.10B : URBAN RIGHT / LEFT AND LEFT / RIGHT STAGGERS
SINGLE 7.3m WITH 3.5m SHADOW ISLAND

ALL DIMENSIONS ARE IN METRES.

LEFT / RIGHT STAGGER

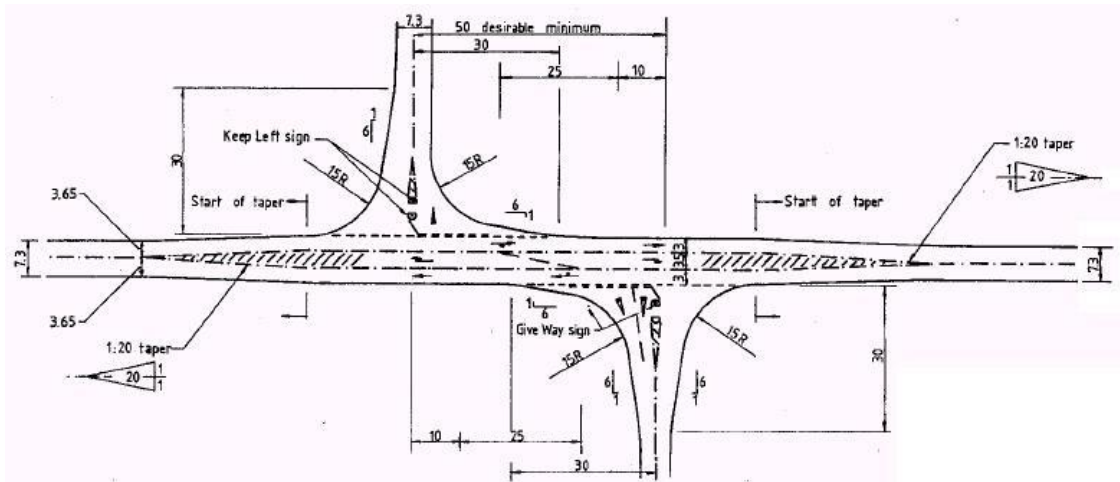

- NOTES:
1. DIAGRAMS DEPICT TYPICAL LAYOUTS UTILISING VARIOUS COMBINATIONS OF GEOMETRIC ELEMENTS. HOWEVER NOT ALL COMBINATIONS HAVE BEEN EXHAUSTED AND ELEMENTS MAY BE EXTRACTED FROM COMPATIBLE DIAGRAMMS TO FORM A NEW COMPOSITE LAYOUT.
 2. LAYOUTS HAVE BEEN DESIGNED TO CATER FOR A 16m ARTICULATED VEHICLE UNLESS OTHERWISE STATED. DESIGN BASED ON A LESS ONEROUS DESIGN VEHICLE MAY BE JUSTIFIED AND GEOMETRIC ELEMENTS REDUCED ACCORDINGLY.
 3. DEPENDING ON PEDESTRIAN VOLUMES, LAYOUT MAY NEED AMENDMENT TO ACCOMODATE AT GRADE PEDESTRIAN CROSSING.

DIAGRAM 4.3.16.11 : RIGHT / LEFT STAGGER - 10m PHYSICAL ISLAND
DRAWN FOR 85A km/h DESIGN SPEED

ALL DIMENSIONS ARE IN METRES.

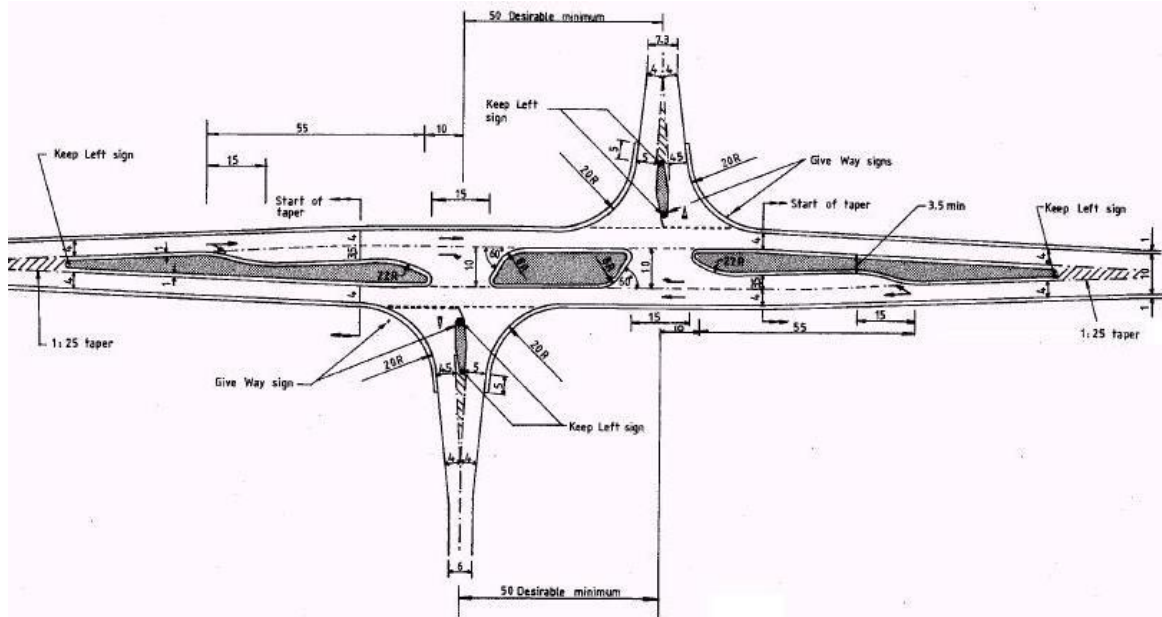

- NOTES:
1. DIAGRAMS DEPICT TYPICAL LAYOUTS UTILISING VARIOUS COMBINATIONS OF GEOMETRIC ELEMENTS. HOWEVER NOT ALL COMBINATIONS HAVE BEEN EXHAUSTED AND ELEMENTS MAY BE EXTRACTED FROM COMPATIBLE DIAGRAM TO FORM A NEW COMPOSITE LAYOUT.
 2. LAYOUTS HAVE BEEN DESIGNED TO CATER FOR A 16m ARTICULATED VEHICLE UNLESS OTHERWISE STATED. DESIGN BASED ON A LESS ONEROUS DESIGN VEHICLE MAY BE JUSTIFIED AND GEOMETRIC ELEMENTS REDUCED ACCORDINGLY.
 3. DEPENDING ON PEDESTRIAN VOLUMES, LAYOUT MAY NEED AMENDMENT TO ACCOMODATE AT GRADE PEDESTRIAN CROSSING.

DIAGRAM 4.3.16.12 : LEFT / RIGHT STAGGER - 10m PHYSICAL ISLAND
DRAWN FOR 85A km/h DESIGN SPEED

ALL DIMENSIONS ARE IN METRES.

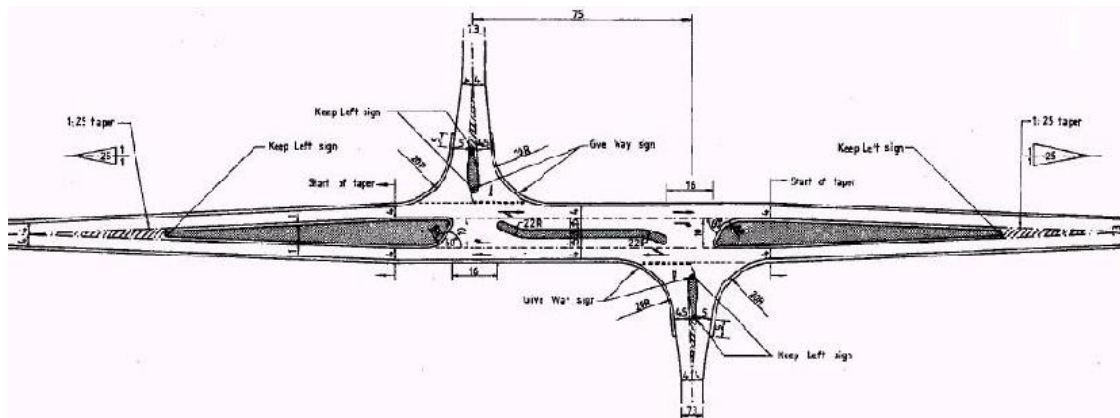

- NOTES:
1. DIAGRAMS DEPICT TYPICAL LAYOUTS UTILISING VARIOUS COMBINATIONS OF GEOMETRIC ELEMENTS. HOWEVER NOT ALL COMBINATIONS HAVE BEEN EXHAUSTED AND ELEMENTS MAY BE EXTRACTED FROM COMPATIBLE DIAGRAMMS TO FORM A NEW COMPOSITE LAYOUT.
 2. LAYOUTS HAVE BEEN DESIGNED TO CATER FOR A 16m ARTICULATED VEHICLE UNLESS OTHERWISE STATED. DESIGN BASED ON A LESS ONEROUS DESIGN VEHICLE MAY BE JUSTIFIED AND GEOMETRIC ELEMENTS REDUCED ACCORDINGLY.
 3. DEPENDING ON PEDESTRIAN VOLUMES, LAYOUT MAY NEED AMENDMENT TO ACCOMODATE AT GRADE PEDESTRIAN CROSSING.

DIAGRAM 4.3.16.13 : CLIMBING LANE THROUGH T-JUNCTION
DRAWN FOR 85A km/h DESIGN SPEED

ALL DIMENSIONS ARE IN METRES.

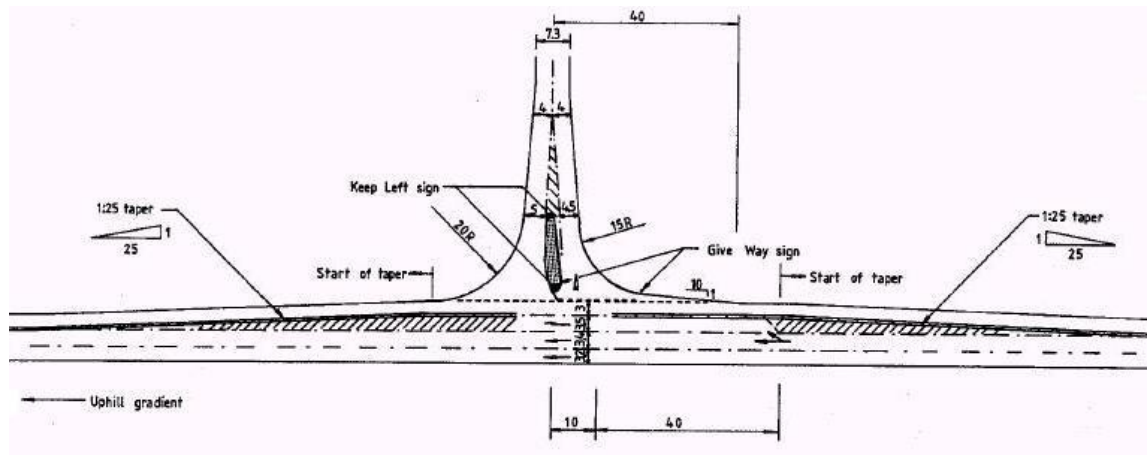

- NOTES:
1. DIAGRAMS DEPICT TYPICAL LAYOUTS UTILISING VARIOUS COMBINATIONS OF GEOMETRIC ELEMENTS. HOWEVER NOT ALL COMBINATIONS HAVE BEEN EXHAUSTED AND ELEMENTS MAY BE EXTRACTED FROM COMPATIBLE DIAGRAMMS TO FORM A NEW COMPOSITE LAYOUT.
 2. LAYOUTS HAVE BEEN DESIGNED TO CATER FOR A 16m ARTICULATED VEHICLE UNLESS OTHERWISE STATED. DESIGN BASED ON A LESS ONEROUS DESIGN VEHICLE MAY BE JUSTIFIED AND GEOMETRIC ELEMENTS REDUCED ACCORDINGLY.
 3. DEPENDING ON PEDESTRIAN VOLUMES, LAYOUT MAY NEED AMENDMENT TO ACCOMODATE AT GRADE PEDESTRIAN CROSSING.

DIAGRAM 4.3.16.14A : SKEW MINOR ROAD**3.5m SHADOW ISLAND****DES. SPEED 70 km/h**

ALL DIMENSIONS ARE IN METRES.

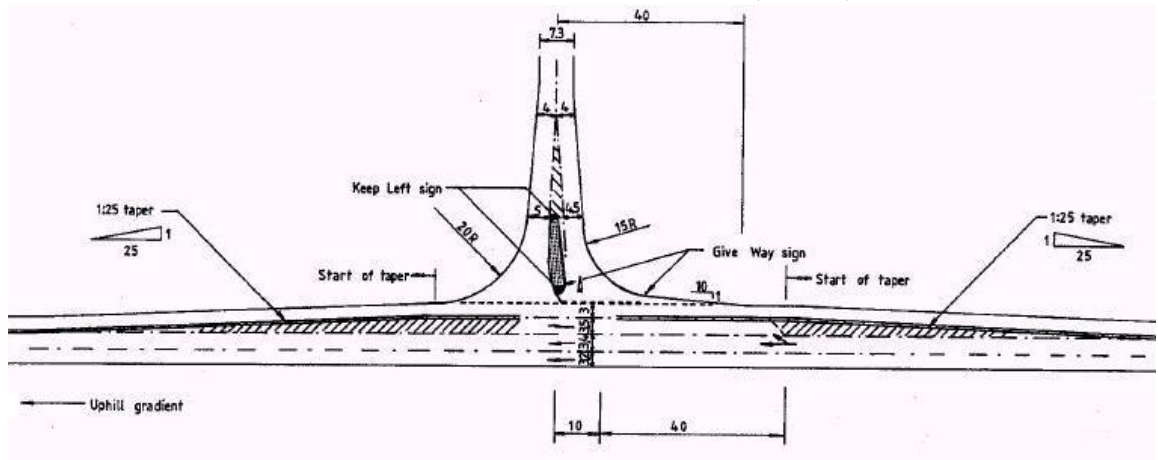
LEFT HAND SPLAY JUNCTION ($\theta \leq 70^\circ$)

- NOTES:
1. DIAGRAMS DEPICT TYPICAL LAYOUTS UTILISING VARIOUS COMBINATIONS OF GEOMETRIC ELEMENTS. HOWEVER NOT ALL COMBINATIONS HAVE BEEN EXHAUSTED AND ELEMENTS MAY BE EXTRACTED FROM COMPATIBLE DIAGRAM TO FORM A NEW COMPOSITE LAYOUT.
 2. LAYOUTS HAVE BEEN DESIGNED TO CATER FOR A 16m ARTICULATED VEHICLE UNLESS OTHERWISE STATED. DESIGN BASED ON A LESS ONEROUS DESIGN VEHICLE MAY BE JUSTIFIED AND GEOMETRIC ELEMENTS REDUCED ACCORDINGLY.
 3. DEPENDING ON PEDESTRIAN VOLUMES, LAYOUT MAY NEED AMENDMENT TO ACCOMODATE AT GRADE PEDESTRIAN CROSSING.

DIAGRAM 4.3.16.14B : SKEW MINOR ROAD**3.5m SHADOW ISLAND****DES. SPEED 70 km/h**

ALL DIMENSIONS ARE IN METRES.

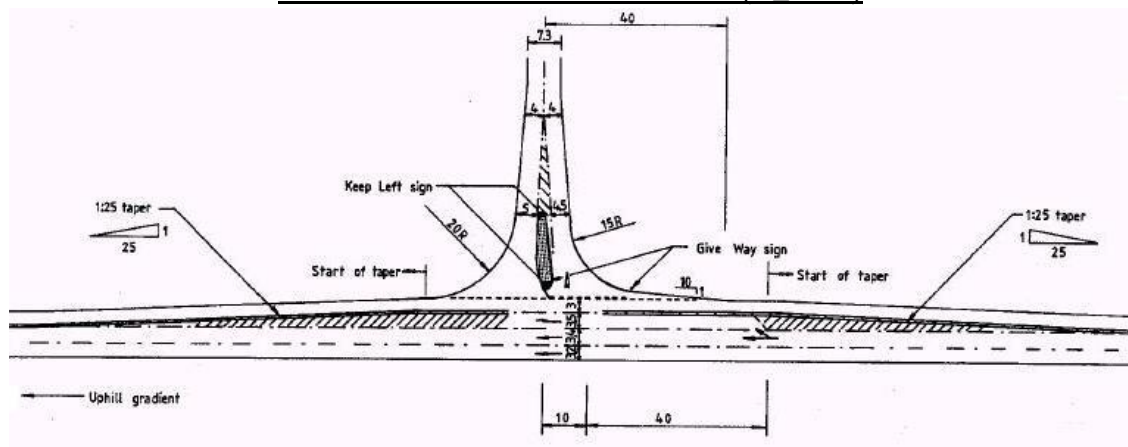
RIGHT HAND SPLAY JUNCTION ($\theta \leq 110^\circ$)

- NOTES:
1. DIAGRAMS DEPICT TYPICAL LAYOUTS UTILISING VARIOUS COMBINATIONS OF GEOMETRIC ELEMENTS. HOWEVER NOT ALL COMBINATIONS HAVE BEEN EXHAUSTED AND ELEMENTS MAY BE EXTRACTED FROM COMPATIBLE DIAGRAMMS TO FORM A NEW COMPOSITE LAYOUT.
 2. LAYOUTS HAVE BEEN DESIGNED TO CATER FOR A 16m ARTICULATED VEHICLE UNLESS OTHERWISE STATED. DESIGN BASED ON A LESS ONEROUS DESIGN VEHICLE MAY BE JUSTIFIED AND GEOMETRIC ELEMENTS REDUCED ACCORDINGLY.
 3. DEPENDING ON PEDESTRIAN VOLUMES, LAYOUT MAY NEED AMENDMENT TO ACCOMODATE AT GRADE PEDESTRIAN CROSSING.

DIAGRAM 4.3.16.15 : MINOR ROAD CHANNELISING ISLANDS

ALL DIMENSIONS ARE IN METRES.

(a) LAYOUT DETAIL FOR T-JUNCTION CHANNELISING ISLAND

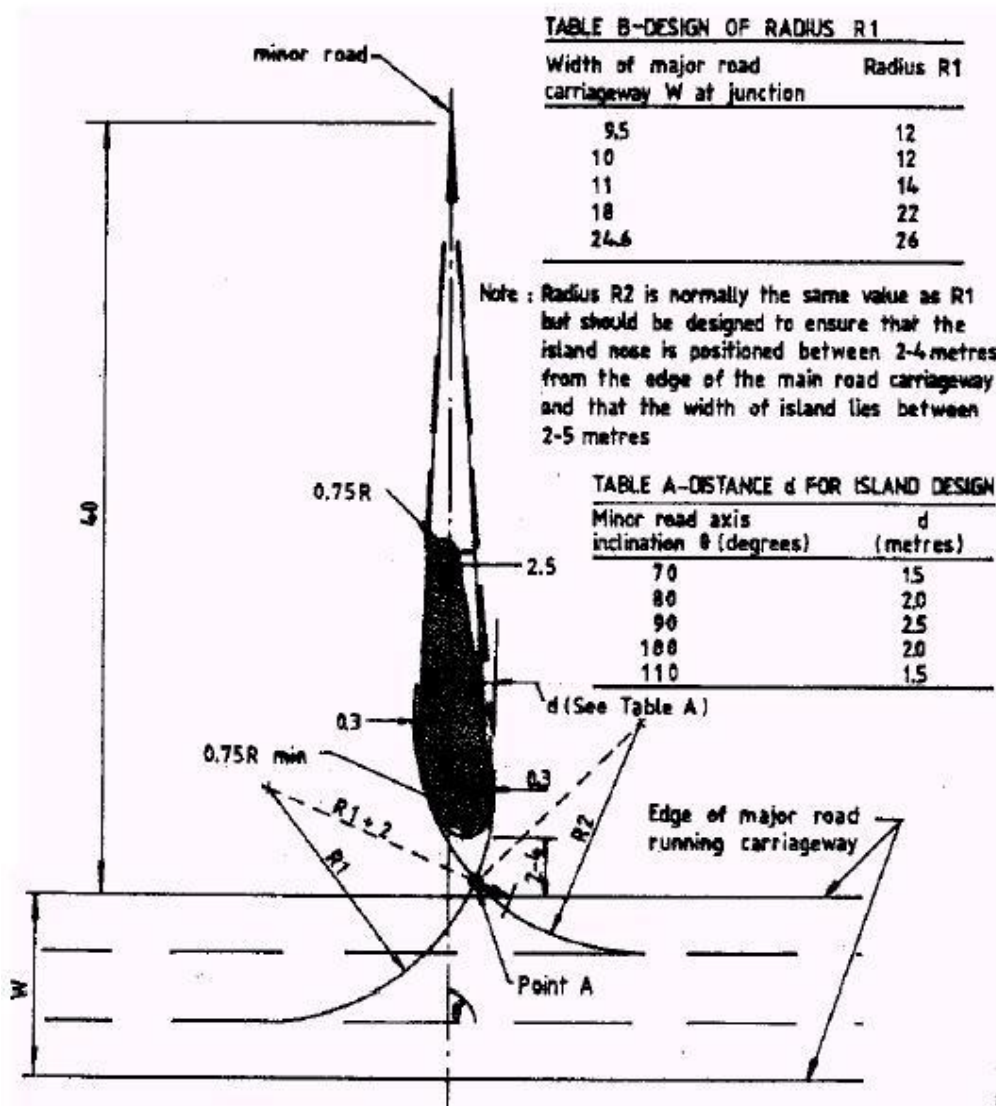

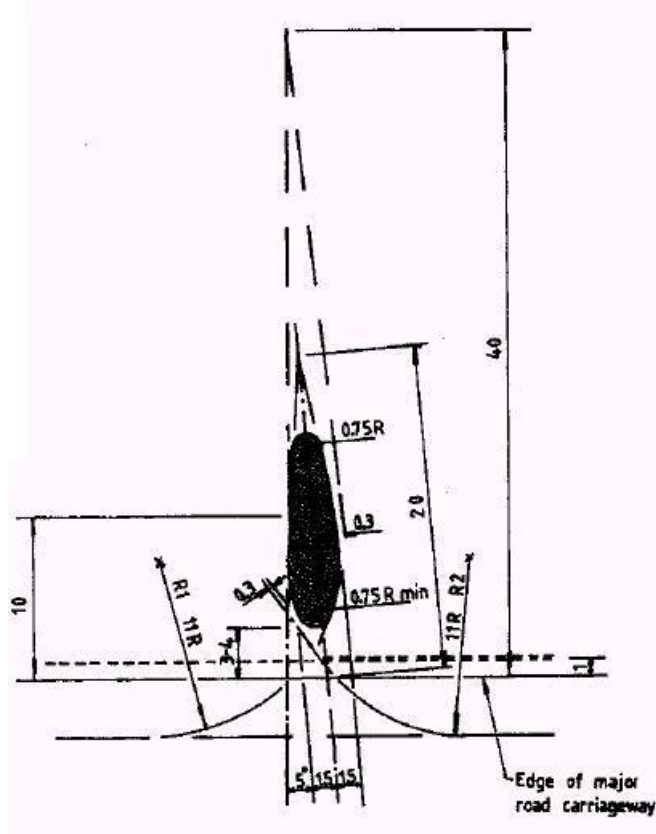
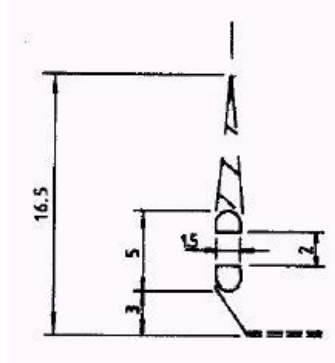
(b) LAYOUT DETAIL FOR RURAL CROSSROADS CHANNELISING ISLAND**(c) LAYOUT DETAIL FOR URBAN SEPARATION ISLAND**

- NOTES:
1. DIAGRAMS DEPICT TYPICAL LAYOUTS UTILISING VARIOUS COMBINATIONS OF GEOMETRIC ELEMENTS. HOWEVER NOT ALL COMBINATIONS HAVE BEEN EXHAUSTED AND ELEMENTS MAY BE EXTRACTED FROM COMPATIBLE DIAGRAM TO FORM A NEW COMPOSITE LAYOUT.
 2. LAYOUTS HAVE BEEN DESIGNED TO CATER FOR A 16m ARTICULATED VEHICLE UNLESS OTHERWISE STATED. DESIGN BASED ON A LESS ONEROUS DESIGN VEHICLE MAY BE JUSTIFIED AND GEOMETRIC ELEMENTS REDUCED ACCORDINGLY.
 3. DEPENDING ON PEDESTRIAN VOLUMES, LAYOUT MAY NEED AMENDMENT TO ACCOMMODATE AT GRADE PEDESTRIAN CROSSING.

4.4 Signal Controlled Junctions

- 4.4.1 The performance of signal controlled junctions in comparison to other types of junction is dealt with in Section 4.2 of this Chapter and summarised in Table 4.2.10.1. For a detailed account of traffic signals, Volume 4 of this manual is dedicated entirely to the subject and the reader is referred thereto.

4.5 Roundabouts

4.5.1 Introduction

- 4.5.1.1 Roundabouts could be considered as a specialized form of Priority Junction. Unlike normal priority junctions, however, where major road traffic receives continuous priority, with roundabouts the flow entering the junction from all arms gives priority to vehicles already in the junction. Roundabouts are thus well suited to situations of balanced flow. Also, because right turns, and all other movements, are broken down into a left turn entry and a left turn exit, roundabouts are well suited to flows containing a high proportion of right turning vehicles.
- 4.5.1.2 There are four basic types of roundabout, namely, Conventional, Spiral, Mini and Double. Other forms of roundabouts which are variants of these four basic types are Grade Separated Roundabouts, Ring Junctions and Signalized Roundabouts.
- 4.5.1.3 A conventional roundabout can be considered as a one-way circulatory carriageway of concentric lanes around a kerbed central island 4m or more in diameter and usually with flared approaches to allow multiple vehicle entry.
- 4.5.1.4 A spiral roundabout is similar to a conventional roundabout but the circulatory carriageway is marked with spiral lane marking encouraging drivers to give way to exiting vehicles. The diameter of the kerbed island of spiral roundabout should not be less than 30m. If the diameter of the inscribed circle is small, spiral lane marking will become short-segmented, which will lead to confusion to drivers and is not desirable.
- 4.5.1.5 A mini roundabout consists of a one-way circulatory carriageway around a flush or slightly raised circular marking (1- 4m in diameter) and with or without flared approaches.
- 4.5.1.6 A double roundabout is a single junction with two single roundabouts either contiguous or connected by a central link road or kerbed island.
- 4.5.1.7 A grade separated roundabout junction is defined as one which includes a roundabout which has at least one entry road, via an interconnecting slip road, from a road at a different level.
- 4.5.1.8 A ring junction retains the large central island characteristic of a roundabout but the usual one-way circulation of vehicles is replaced by two-way circulation with three-arm mini roundabouts and/or traffic signals controlling the junction with each approach arm.
- 4.5.1.9 A signalized roundabout is a roundabout with traffic signals installed on one or more of the approach arms.

4.5.2 Conventional Roundabouts

- 4.5.2.1 The long parallel sided weaving sections, required before the offside priority rule was introduced, have now been replaced with shorter wider sections and much greater importance is attached to the geometry of the entry. The revised geometrical requirements effectively result in a much reduced land take when compared with the former designs and this fact is of particular significance in the territory where land is usually a constraint.
- 4.5.2.2 The number of entries recommended for a conventional roundabout is three or four. Roundabouts perform particularly well with three entries and balanced traffic flows. If the number of entries is greater than four, driver comprehension is affected and the roundabout becomes larger with the probability that higher circulatory speeds will be generated.

4.5.3 Spiral Roundabouts

- 4.5.3.1 With the completion of the district-wide trial of two-lane spiral roundabouts at 10 locations, a comprehensive assessment on the performances of spiral roundabouts in aspects such as driving behaviour, operational efficiency and accident records has been conducted. The assessment has revealed that albeit no significant reduction in the accident figures, the use of spiral lane marking proves to be beneficial operationally by increasing the utilization of inner circulatory lane. Since the commencement of the trial, the 10 spiral roundabouts have been operated smoothly and are well received by motorists.
- 4.5.3.2 Spiral lane markings can be considered for roundabout with diameter of kerbed island 30m or more when the following criteria are met:
- (i) number of exit arms should be at least three;
 - (ii) the circulatory area is of 2-lane; and
 - (iii) desirably all exit arms consist of two traffic lanes, or in less desirable case, only one exit arm consists of one traffic lane.
- 4.5.3.3 Concentric lane marking, instead of spiral marking, should be adopted at the exit arm with one traffic lane only. It is because spiral lane markings cannot be applied to guide the traffic at the inner circulatory lane exiting the roundabout when the exit arm only provides one traffic lane. The details of road markings for spiral roundabout are as shown in Diagram 5.6.5.2(ii) of Volume 3.
- 4.5.3.4 Spiral lane marking reduces the uncertainty experienced by drivers leaving the roundabout, and helps drivers get in the appropriate lane for their desired exits, especially for the right-turning traffic, by not mis-using the outer circulatory lane for right-turning. For conventional roundabout, vehicles traveling in the inner circulatory lane may find difficulties in exiting the roundabout due to conflict with vehicles traveling in the outer lane, and hence drivers will tend to use the outer lane even they are making right turning movement. Such a driving behaviour will result in low usage of the inner circulatory lane. With the spiral lane marking guiding vehicles in the inner lane exiting the roundabout, spiral roundabouts can be effective in distributing traffic flow between the inner and outer circulatory lanes and avoiding under-usage of the inner circulatory lane.
- 4.5.3.5 Spiral lane markings should only be considered where the circulatory area has sufficient width to accommodate two traffic lanes. Where the size and shape of the roundabout is such that sharp manoeuvres would be required between successive entries and exits when following the lanes, spiral marking may not be appropriate.
- 4.5.3.6 Spiral roundabouts with three circulatory lanes will result in complex road markings and may cause confusion to drivers. Therefore, spiral lane markings should not be used for three-lane roundabouts. For improvement of existing three-lane conventional roundabouts, the proposal of dedicating an exclusive left-turn lane at each of the three-lane approach arms of the roundabout and converting the three-lane conventional roundabout to two-lane roundabout can be considered.

4.5.4 Mini Roundabouts

- 4.5.4.1 Mini roundabouts can be extremely effective in improving existing urban junctions that experience capacity problems. Their economical use of land recommends them for many situations in Hong Kong particularly where T-junctions with balanced traffic flows exist. They should only be used when all approaches are subject to a 50 km/h speed limit. Above this speed, problems will arise from motorists not being aware, sufficiently early, that they are approaching a roundabout. If the approach speed is likely to be high, the location, layout design and signing should ensure that vehicles have slowed down to an appropriate speed prior to reaching the roundabout. As the accident frequency tends to increase with the number of arms, mini roundabout should not be introduced at junctions with more than four arms.
- 4.5.4.2 As with other roundabouts, vehicle paths should be deflected to reduce their speed within the roundabout. Physical deflection on the approach may not be possible with mini roundabouts, owing to space constraints, and in such cases road markings and small deflection islands should be used. These islands should be free of all street furniture except the keep left bollards and other essential signs. Diagram No. 4.5.4.1 shows the use of deflection islands at conventional, spiral and mini roundabouts.
- 4.5.4.3 The central island (1 to 4 m diameter) should be as large as possible in relation to the site and domed up to a maximum height of 125mm at the centre. The dome should be completely white and reflectorized. Domes surfaced with natural stone materials etc. are not appropriate as they do not show sufficient contrast with the surrounding road surface. A ring of omni-directional reflective road studs around the periphery of the dome has been found effective in increasing conspicuity at night. No bollards, signs, lighting columns or any other street furniture should be placed on the dome.
- 4.5.4.4 Where space is very restricted, the repeated over-running of the central island by long vehicles will be unavoidable and in such cases the dome may be replaced by a circular reflectorized road marking, with its periphery delineated by reflective road studs.

DIAGRAM 4.5.4.1 : DEFLECTION ISLANDS AT ROUNDABOUTS

CONVENTIONAL ROUNDABOUT

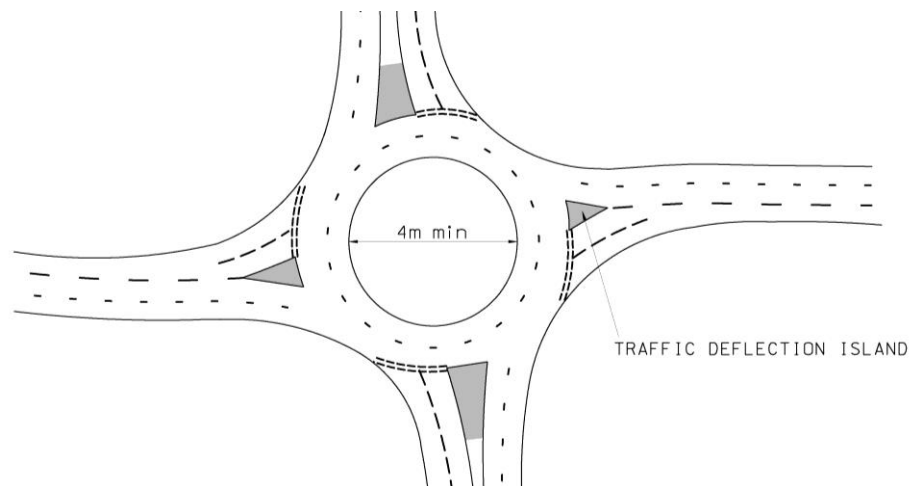

SPIRAL ROUNDABOUT

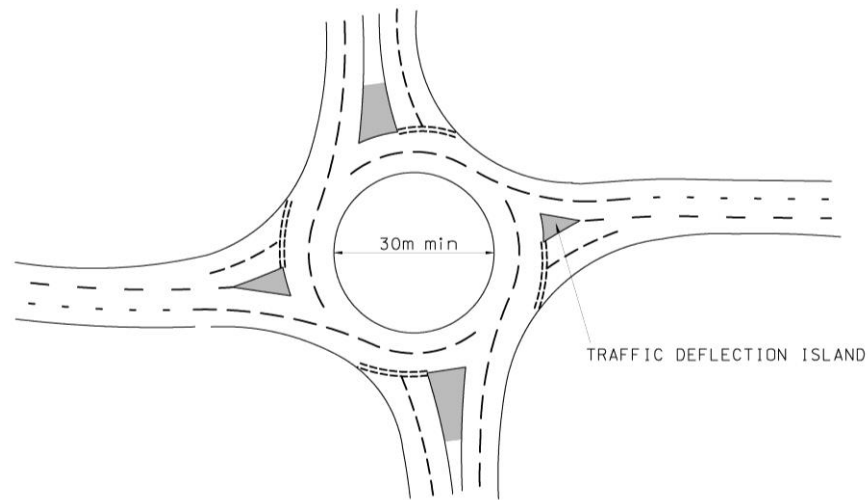

MINI ROUNDABOUTS

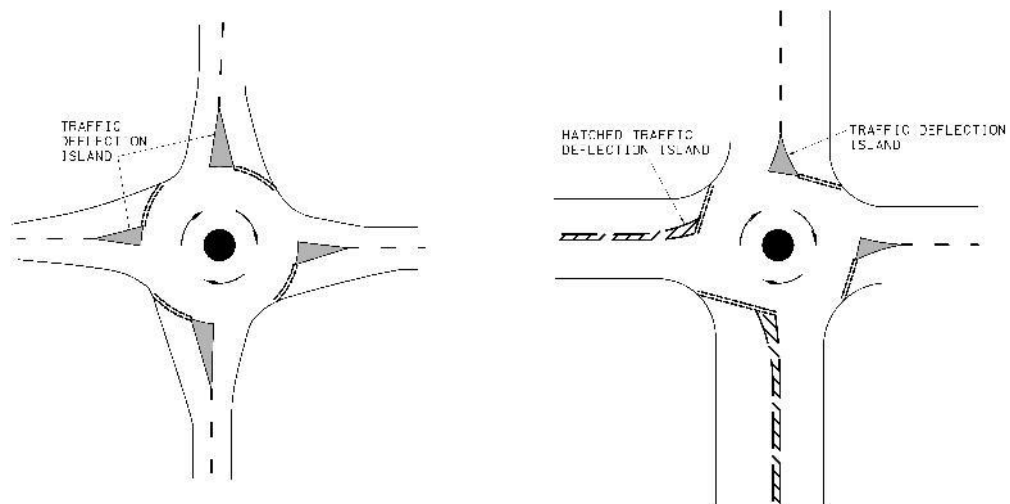

4.5.5 Double Roundabouts

4.5.5.1

As mentioned in paragraph 4.5.2.2, where a junction has more than four entries, a double roundabout may be preferable to a single roundabout. In such a situation, a double roundabout achieves better capacity with acceptable safety characteristics in conjunction with a more efficient use of space. Other situations where double roundabouts can be particularly useful include :

- (i) The improvement to an existing staggered junction where it avoids the need to realign one of the approach roads thereby achieving a considerable saving in construction costs;
- (ii) At unusual or a symmetrical junctions, such as scissors junctions, where the installation of a single island roundabout would require extensive realignment of the approaches or excessive land take (see Diagram No. 4.5.5.1);
- (iii) At the joining of two parallel routes separated by a feature such as a river or railway line;
- (iv) At existing crossroads where it is desirable to separate opposing right turning movements allowing them to pass nearside to nearside (see Diagram No. 4.5.5.1); and
- (v) At overloaded single roundabouts where, by reducing the circulating flow past critical entries, it increases capacity.

4.5.5.2

Where the double roundabout is comprised of mini roundabouts, they should only be used where all the approaches are subject to a 50 km/h speed limit.

DIAGRAM 4.5.5.1 : TYPICAL DOUBLE ROUNDABOUT LAYOUTS

CONTIGUOUS DOUBLE ROUNDABOUT

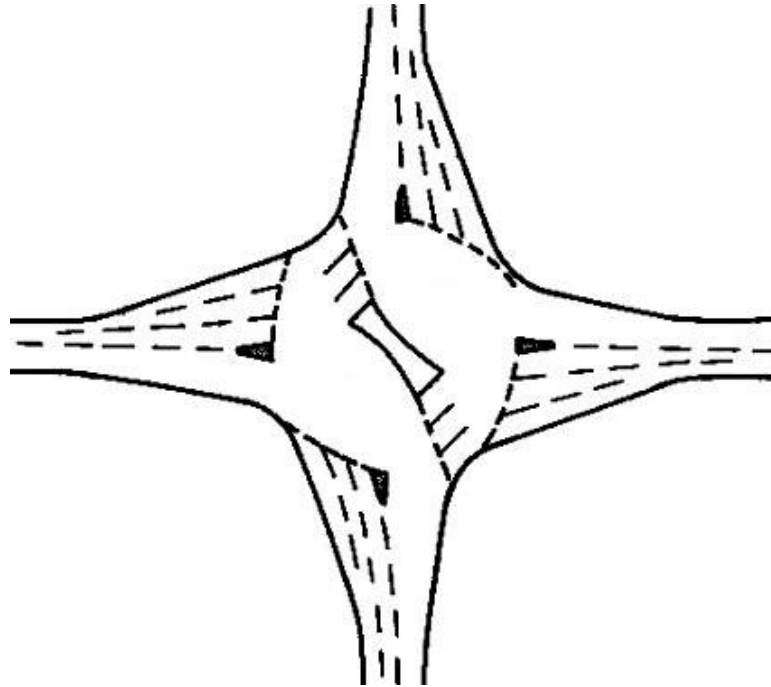

DOUBLE ROUNDABOUT WITH SHORT CENTRAL LINK ROAD
[FOR SITUATIONS DESCRIBED IN PARAGRAPH 4.5.5.1 (ii) + (iii)]

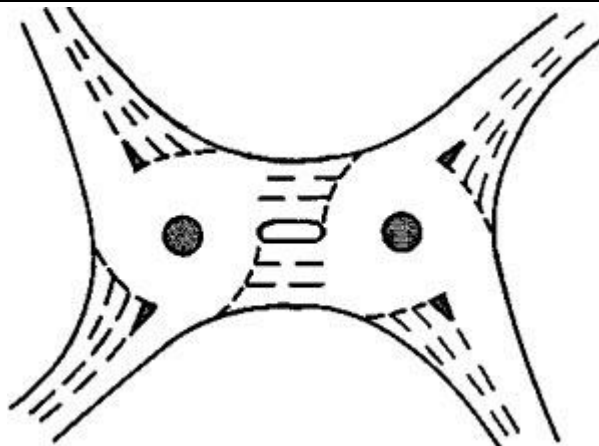

4.5.6 Other Types of Roundabout

- 4.5.6.1 Variations on the four basic forms of roundabout discussed above include Grade Separated Roundabouts, Ring Junctions and Signalized Roundabouts. The most common forms of roundabout used at grade separated junctions are the two-bridge type and the dumbbell type, both of which are shown in Diagram No. 4.5.6.1. The two-bridge type suffers from its large size which increases speeds within the circulatory section, thereby reducing capacity and safety. Design of this type should therefore be made as compact as possible. The dumbbell roundabout design has the advantage of compactness and low construction costs.
- 4.5.5.2 The conversion to ring junction is an effective solution for very large roundabouts which exhibit entry problems. Studies have shown that rings junction layouts can eliminate congestion without reducing safety. There are no existing roundabouts in the territory however, which are large enough for consideration to converting to ring junction control and it is unlikely that such layouts will ever form part of our road network.
- 4.5.5.3 Signalized roundabouts, in certain circumstances, may constitute a most useful design tool. The need for signals at a roundabout normally stems from problems associated with one or more particularly dominant flows which tends to defeat the self regulating property of the roundabout. By installing traffic signals, entry to the roundabout can be regulated thus creating entry opportunities for the non-dominant flows.

DIAGRAM 4.5.6.1 : TYPES OF GRADE SEPARATED ROUNDABOUTS
TWO-BRIDGE ROUNDABOUT AT GRADE SEPARATED INTERCHANGE

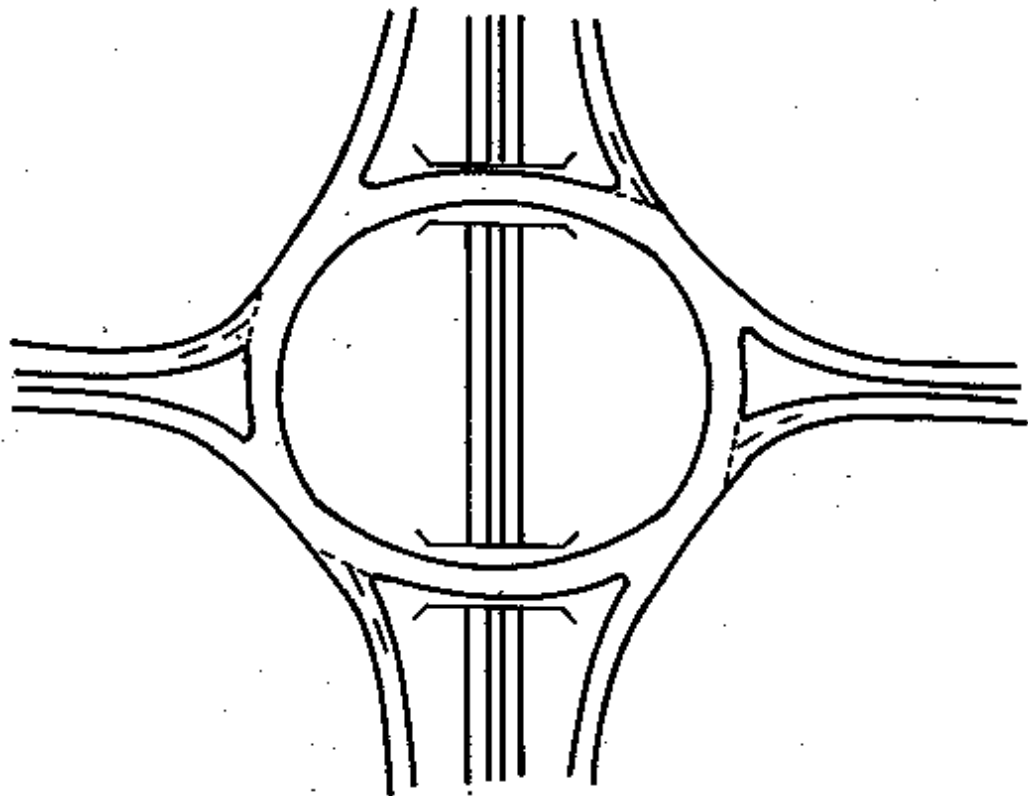

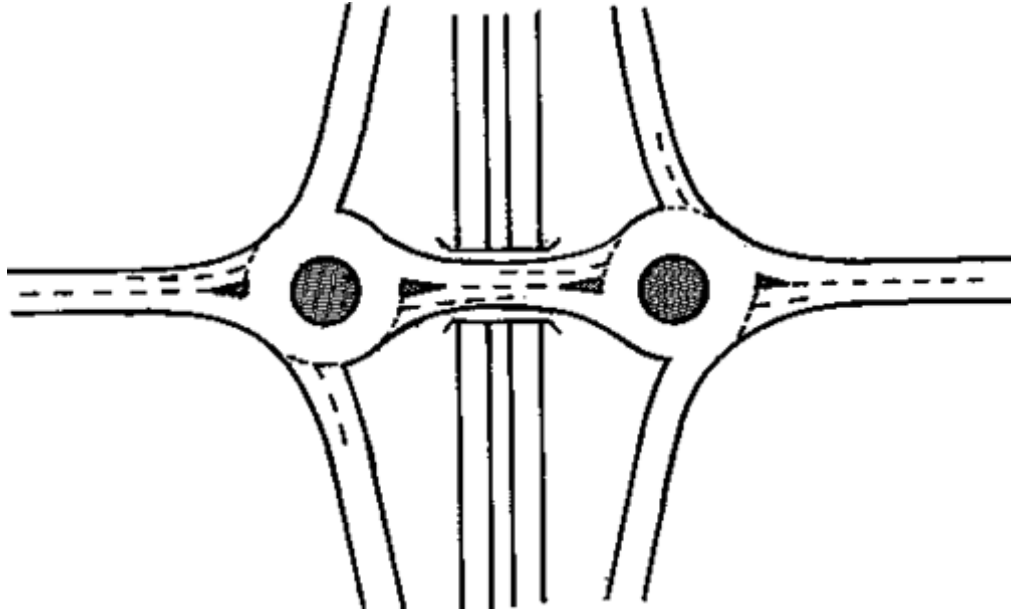
GRADE SEPARATED INTERCHANGE WITH ONE BRIDGE AND TWO ROUNDABOUTS**– ‘DUMBBELL INTERCHANGE’****4.5.7 Siting of Roundabouts**

4.5.7.1 Roundabouts should be sited on level ground or in sags, where drivers' advanced visibility of the junction is good, rather than on crests of hills where, while approaching, they will have difficulty in appreciating the layout.

4.5.7.2 Roundabouts are appropriate in urban areas but are generally not compatible with Area Traffic Control systems. Roundabouts, in these situations, interfere with the platoon movement to the extent that inflows to downstream traffic signals cannot be reliably predicted and optimization of signal setting cannot be achieved.

4.5.7.3 As already stated, the viability of roundabout design depends on the need to reduce all vehicle speeds through the junction. This property of the roundabout may be used to good advantage in the following circumstances :

- (i) Where there is a significant change in road standard, say from dual to single carriageways or from grade separated to at-grade sections of road; or
- (ii) To emphasise the transition from rural to urban environment.

In such circumstances, the roundabout serves as a very useful punctuation mark in the road network.

4.5.6.4 On single carriageways where overtaking opportunities are limited, it may be advantageous to replace a large radius curve at a junction with two straight sections leading into a small radius curve at a roundabout, as shown in Diagram No. 4.5.7.1. By so doing, overtaking sections are created and the revised alignment may also have advantages in reduced land take.

4.5.6.5 Roundabouts may also be sited to good effect to provide "U" turn facilities for example to service frontage properties along a dual carriageway district or local distributor road.

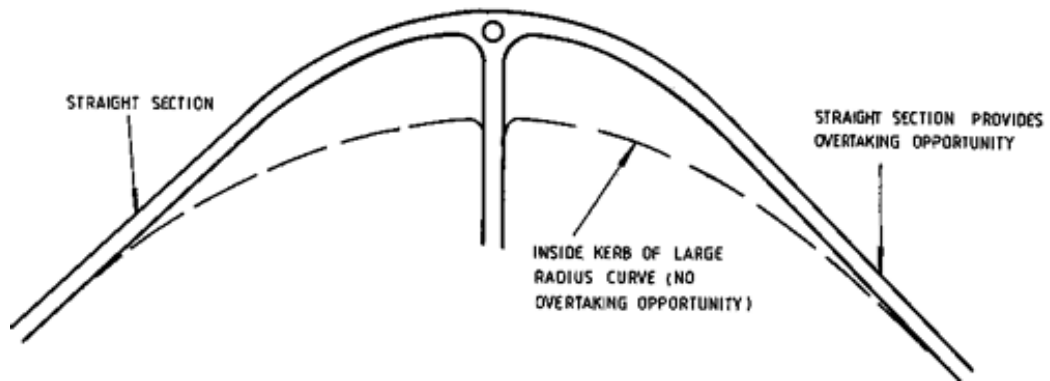
DIAGRAM 4.5.7.1 : USE OF ROUNDABOUT TO CHANGE ALIGNMENT**4.5.8 Safety at Roundabouts**

- 4.5.8.1 In general, a well designed roundabout will cause fewer accidents than a signal controlled junction handling the same volume of traffic. The severity of accidents at roundabouts is also lower than that of all other junction types and mid-link locations.
- 4.5.8.2 The most important factors affecting safety at roundabouts are the entry and circulatory speeds. High speeds are normally associated with large roundabouts having excessively long and/or wide circulatory carriageways, but they can also be caused at smaller roundabouts by inadequate entry deflection. Other factors inducing high speeds at roundabouts include very acute entry angles which encourage fast merging, poor visibility to the "Give Way" line and poorly designed and located warning and advance direction signs.
- 4.5.8.3 Measures which have been found to improve safety at roundabouts include, the provision of appropriate levels of skid resistance on the approaches and circulatory carriageway; the avoidance of abrupt and excessive super-elevation in the entry region; the reduction of excessive entry width by hatching or physical means; and the provision of "Reduce Speed Now" signs and "Yellow Bar" markings on the approaches. Volume 3 Chapter 5 gives detailed information on the use of "Yellow Bar" markings.
- 4.5.8.4 Though roundabouts have an impressive overall safety record for most vehicle types, this does not apply equally to two wheeled vehicles. Statistics from the United Kingdom show that accident involvement rates for two-wheeled vehicles, expressed in terms of accidents per road user movement, are 10-15 times those of cars; with pedal cyclists having a slightly higher accident rate than motorcyclists. It is useful to note that different types of roundabouts exhibited different results in this respect. For example, roundabouts with small central islands and flared entries have accident rates which are about twice those of conventional/spiral roundabouts with large central islands and unflared entries. This relationship appears to apply consistently for all types of vehicle.
- 4.5.8.5 Heavy goods vehicle accidents at roundabouts frequently involve the shedding of loads. Roundabouts, where this problem has been encountered usually exhibit one or more of the following features: inadequate entry deflection, long straight sections of circulatory carriageway, sharp turns into exits, excessive crossfall changes on the circulatory carriageway and excessive adverse crossfall on a nearside lane of the circulatory carriageway.

4.5.9 Pedestrian & Cyclist Facilities at Roundabouts

- 4.5.9.1 Separate pedestrian routes with crossings away from the flared entries to roundabouts are preferable. Here the carriageway widths are less and vehicular traffic movements are more straight-forward. Also, the greater the distance between the crossing and the give way line the less the vehicular capacity of the entry will be affected. One should ensure however that the pedestrian routing thus created is not so diverse as to be unattractive.

4.5.9.2 For at-grade crossings, both cautionary and zebra installations are compatible with roundabout layouts. A central refuge should always be provided where carriageway width permits and deflection islands; if a minimum of 1.25m wide, can serve this purpose. Guardrails should be used to prevent indiscriminate crossing of the carriageway. Grade separated pedestrian facilities should be considered where pedestrian volumes are high. Subway links interconnecting within the central island can often prove to be viable solutions where large roundabouts are concerned.

4.5.9.3 As discussed in the previous section, roundabouts can be particularly hazardous for cyclists and where substantial numbers of cyclists are expected the following measures should be considered :

- (i) Full grade separation;
- (ii) A signposted alternative cycle route away from the roundabout;
- (iii) A roundabout design which emphasizes safety rather than capacity;
- (iv) An alternative form of junction, such as traffic signals.

4.5.10 Capacity of Roundabouts

4.5.10.1 Conventional roundabouts consisted of large central islands with long parallel sided weaving sections. The capacity of the roundabout was measured in terms of the capacity of its individual weaving sections using Wardrop's Formula. With the introduction of small and mini roundabouts the emphasis was placed on shorter wider weaving sections (in fact little weaving takes place) and flared approaches. The capacity of this type of roundabout was calculated for the junction as a whole based on the basic road widths and areas of widening at the junction. These formulae have now been superseded by a predictive equation, giving the capacity of each entry to the roundabout, which is applicable to all types of roundabout.

4.5.10.2 Since the introduction of the offside priority rule, traffic waiting to enter a roundabout on one am has to give priority to traffic already on the circulatory carriageway crossing the entry. Consequently, the entry capacity decreases as the circulating flow increases, since there are then fewer opportunities for waiting drivers to enter the circulation. When entry opportunities do present themselves the number of vehicles which are able to avail themselves of the opportunity depends on the entry width, the circulatory width, the entry angle and other geometric characteristics of the roundabout layout. The predictive equations are thus stated in terms of the circulating flow and the geometric parameters, and are based on multiple regression analyses from observations at a large number of sites in the United Kingdom.

4.5.10.3 In evaluating a proposed layout, the design flow for each entry, derived as described in para. 4.2.4, should be compared with the calculated capacity to produce a design flow/capacity ratio (DFC). The entry capacity is defined as the maximum in-flow from an entry when the demand flow is sufficient to cause steady queuing in the approach. A DFC ratio of 100% would therefore indicate continual queuing and could not be considered acceptable. A DFC ratio of 85%, indicating that queuing would theoretically be avoided in 85% of cases, can be considered reasonable. A DFC of 70% indicates that queuing will be avoided in 95% of cases. The acceptable value of DFC will vary in relation to individual circumstances. For example in a situation where future improvement to the junction would be impossible a lower DFC than otherwise considered reasonable may need to be achieved.

4.5.10.4 The predictive equation for roundabout capacity together with definitions of parameters and explanatory diagrams is given in [Appendix 2](#). It will be readily appreciated however that the process of computation is necessarily iterative in nature. As a capacity for one entry varies so does the potential circulating flow across a different entry with a subsequent change in the capacity of that entry, and so on. This iterative process is best suited to computer application and the program ARCADY, which should be available in the territory in the near future, can carry out the computation. This program will calculate queue lengths and delays for each time segment. In the absence of the computer program the computation can be carried out manually to give a preliminary assessment of layout viability and a worked example is included in Appendix 2.

4.5.11 General Layout Requirements

4.5.11.1 The principal objective of roundabout design is to secure the safe interchange of traffic between crossing and weaving traffic streams with minimum delay. This is achieved by a combination of the geometric layout features described in the following paragraphs. As relationships between aspects of design are not always mutually compatible, design becomes a trade off between operational efficiency minimizing delays and achieving safety.

4.5.11.2 Where geometric design parameters are speed related, at existing junctions or new junctions on existing roads, the measured 85th percentile speed should be used, rounded up to the next highest design speed step. For completely new junctions, the design speed of the roads should be used.

4.5.11.3 The geometric parameters described in subsequent paragraphs are depicted in Figures 1 - 5 of Appendix 2 with accompanying detailed description.

4.5.12 Visibility

4.5.12.1 The following guidelines represent good practice concerning the provision of visibility and when not complied with there is need for additional signing to alert drivers of all vehicles to potential hazards. Visibility distances should be measured between a driver's eye height of 1.05m and an object height of 1.05m, both measured from the centre line of each lane.

4.5.12.2 The forward visibility at the approach to a roundabout shall not be less than that shown in Table 4.5.12.1 below (c.f. Table 3.3.5.1 in Chapter 3 of this volume). The visibility distance should be measured to the "Give Way" line as shown in Diagram No. 4.5.12.1.

Table 4.5.12.1
Sight Distances

Design Speed (km/h)	100	85	70	60	50
Desirable Minimum (m)	225	165	125	95	70
Absolute Minimum (m)	165	125	95	70	50

4.5.12.3 As drivers get closer to the "Give Way" line they should be able to see the full width of the circulatory carriageway, to their right, as far as the previous entry or for a distance of 50m, measured along the centre of the circulatory carriageway, whichever is the lesser. This visibility should be available from the centre of the offside lane at a distance of 15m back from the "Give Way" line as shown in Diagram No. 4.5.12.2.

- 4.5.12.4 In addition to the visibility to the right, approaching motorists also require visibility ahead which similarly should extend to the next exit or for a distance of 50m, measured along the centre of the circulatory carriageway, whichever is the lesser. This visibility should be available from the centre of the nearside lane at a distance of 15m back from the "Give Way" line as shown in Diagram No. 4.5.12.3.
- 4.5.12.5 Drivers of all vehicles circulating on a roundabout should be able to see the full width of the circulatory carriageway ahead of them as far as the next exit or for a distance of 50m, whichever is the lesser. This visibility should be checked from a point 2m in from the central island as shown in Diagram No. 4.5.12.4.
- 4.5.12.6 Where a pedestrian crossing is located across the entry to a roundabout, drivers approaching the roundabout should have visibility to the crossing of a distance not less than that shown in Table 4.5.12.1. Additionally, drivers at the "Give Way" line of one entry should be able to see the full width of a crossing located at the next entry if this is within 50m of the roundabout. This requirement, illustrated in Drawing No. 4.5.12.5, may be difficult to achieve in urban areas owing to adjacent roadside development.
- 4.5.12.7 Particular attention should be paid to visibility requirements at grade separated junctions to ensure that visibility is not obstructed by safety fences or bridge parapets in the case of elevated roundabouts and by flyover abutments in the case of a flyover.

DIAGRAM 4.5.12.1 : MEASUREMENT OF APPROACH VISIBILITY
DESIRABLE / MINIMUM VISIBILITY DISTANCE FOR APPROACH ROAD DESIGN
SPEED

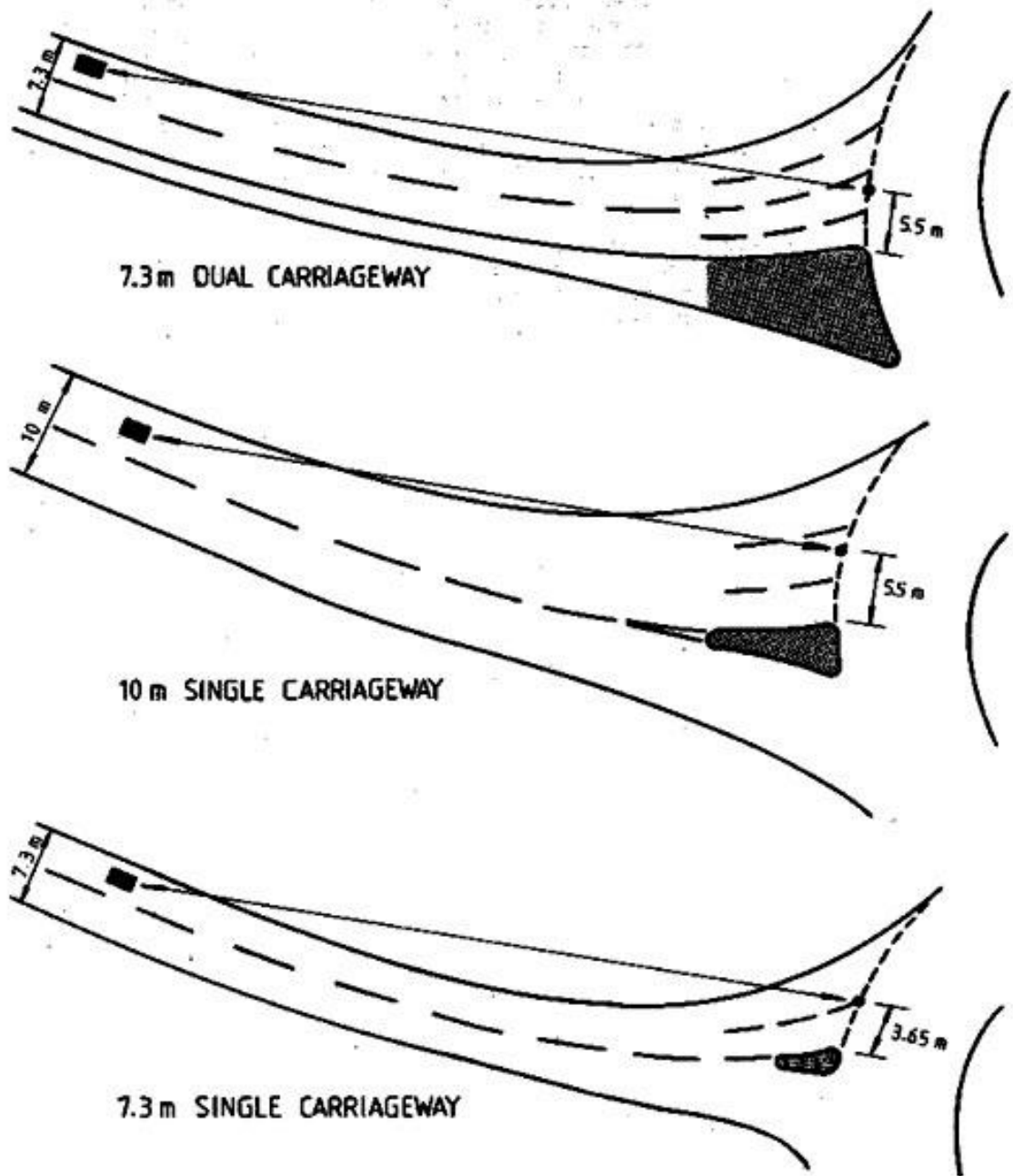

DIAGRAM 4.5.12.2 : VISIBILITY TO THE RIGHT REQUIRED AT ENTRY

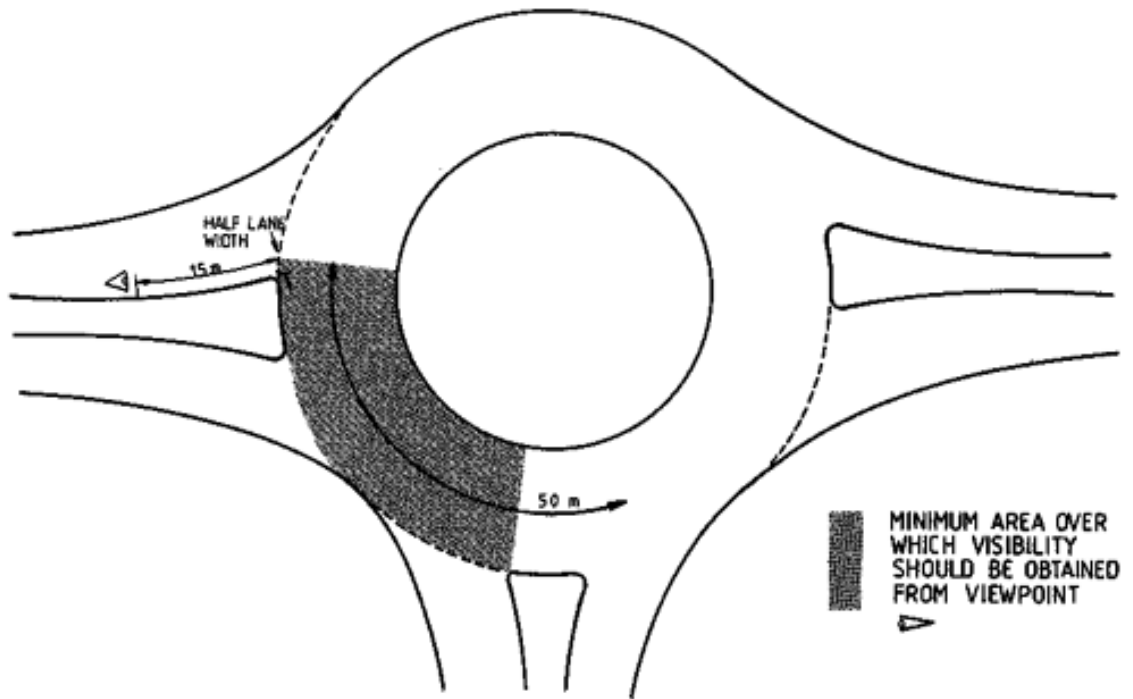

DIAGRAM 4.5.12.3 : FORWARD VISIBILITY REQUIRED AT ENTRY

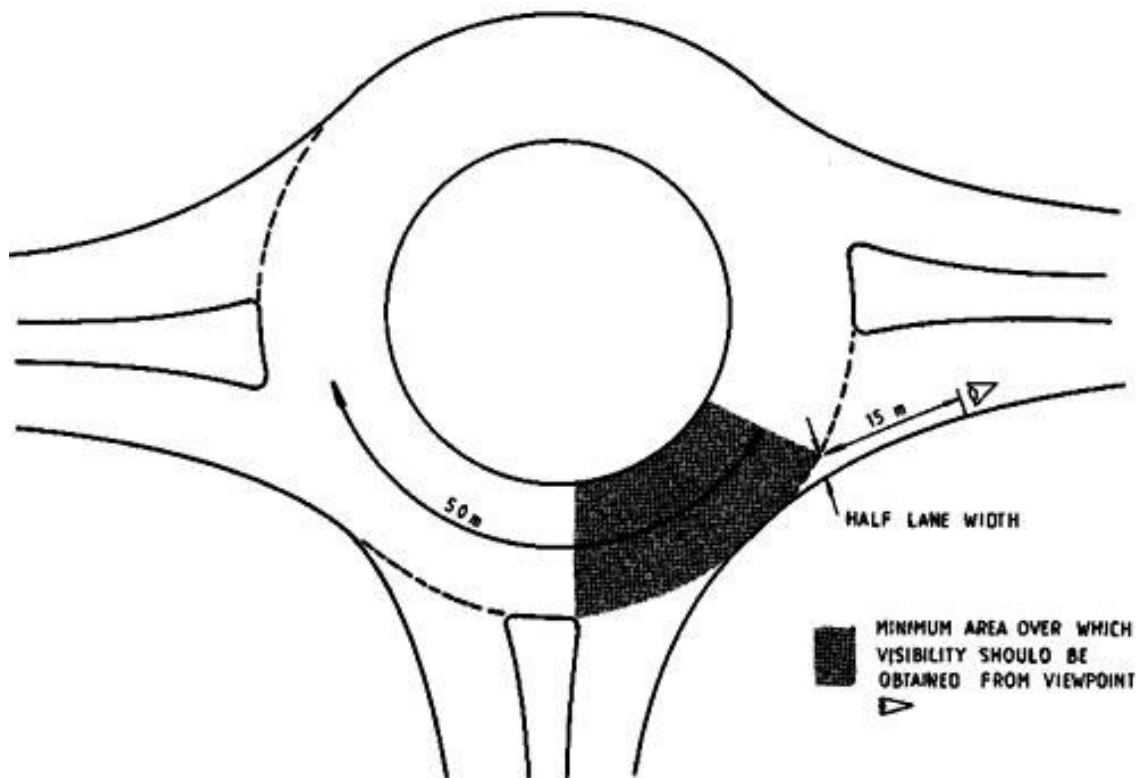

DIAGRAM 4.5.12.4 : CIRCULATORY VISIBILITY REQUIRED

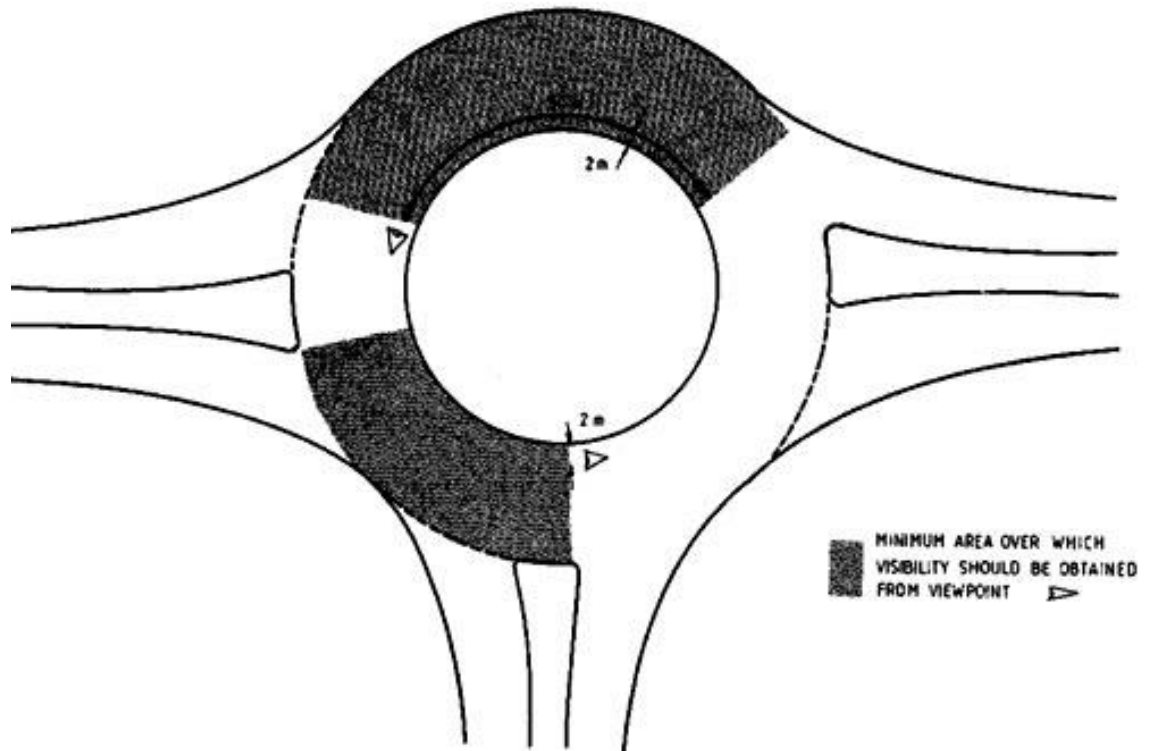
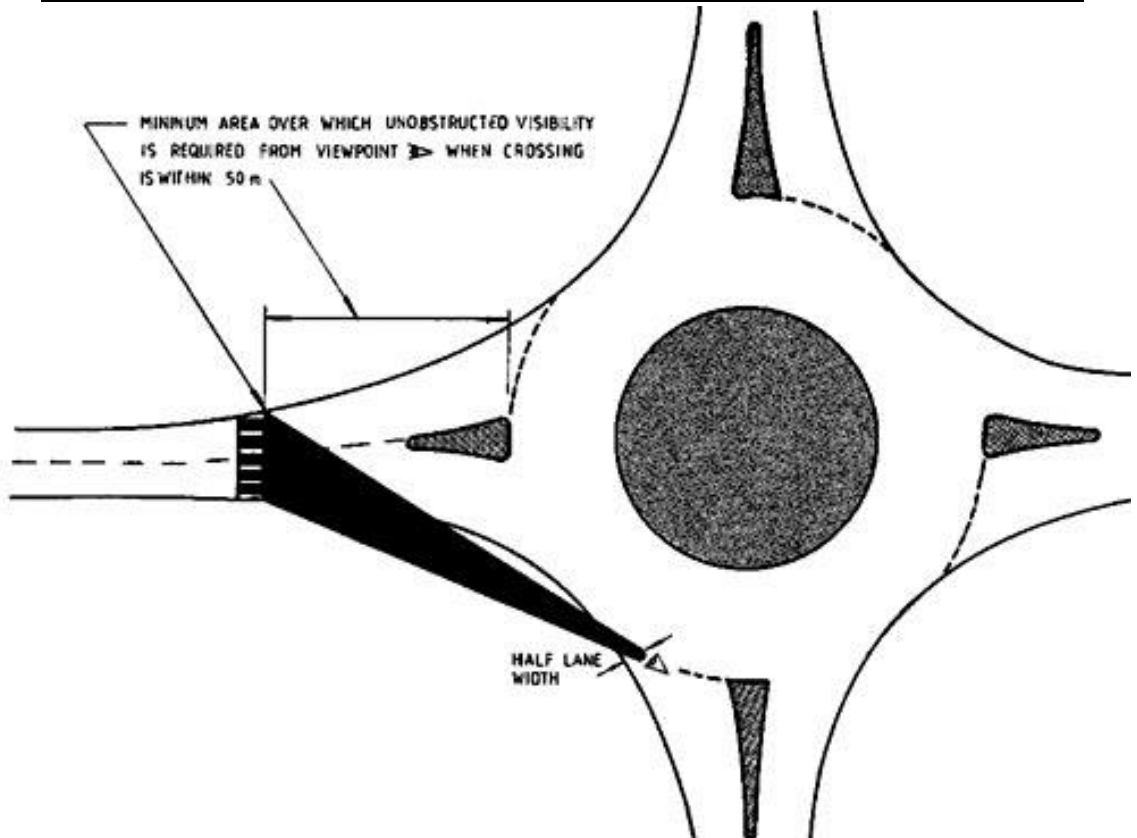

DIAGRAM 4.5.12.5 : PEDESTRIAN CROSSING VISIBILITY REQUIREMENTS



4.5.13 Roundabout Entries

- 4.5.13.1 The geometric parameters related to roundabout entries are entry width, flare length, entry angle and entry deflection.
- 4.5.13.2 Entry width is the most important feature determining entry capacity. As a general rule one or two lanes should be added on the entry approach up to a maximum width of four lanes. Even when two lanes are not required on capacity grounds, the extra lane should be provided to add flexibility in dealing with long vehicles and broken down vehicles. Entry widening should be effected on the nearside to avoid the introduction of reverse curves. Lane widths should be a minimum of 2.5m at the entry, tapered back in the entry flare to a minimum of 2m wide. It is generally better, for dealing with heavy goods vehicles, to use wider lane widths e.g. 3 x 3.33m lanes in preference to 4 x 2.5m lanes.
- 4.5.13.3 Effective flare length should be a minimum of about 5m in urban areas whilst a length of 25m is considered reasonable in rural areas. As a rough guide the total length of entry widening should be about twice the average effective flare length as shown in Fig. 2 of Appendix 2.
- 4.5.13.4 The entry angle, as shown in Figs. 4, 5 and 6 of Appendix 2, should ideally be about 30 degrees and in any case be within the range 20 to 60 degrees if possible. Entry angles which are too low force drivers into merging positions where they may disregard the "Give Way" control and enter at high speeds. High entry angles can lead to sharp braking at entries accompanied by "nose to tail" accidents.
- 4.5.13.5 Entry deflection governs the speed of vehicles through the junction and is the most important factor determining safety. Achieving adequate deflection of vehicles on entry is particularly important on roads with high approach speeds. A measure of entry deflection is given by the entry path curvature and this should be restricted to an absolute maximum of 100m in the vicinity of the entry; a good practical design radius is about 20m. A suggested method for the measurement of entry path radius is given in Appendix 2.
- 4.5.13.6 There are various methods for creating adequate entry deflection. On new schemes, where possible, adequate deflection can be obtained whilst still maintaining a compact layout by staggering the entries as shown in Diagram No. 4.5.13.1. In some cases, particularly in urban areas, the approach geometry may be so restricted as to make it impossible to achieve adequate deflection by alignment of entries alone. In such cases deflection should be generated by means of enlarged traffic deflection islands or by subsidiary traffic deflection islands in the entry as shown in Diagram Nos. 4.5.13.2 and 4.5.13.3. Subsidiary deflection islands may be surfaced in white reflective material and circumscribed with reflecting road studs to improve their conspicuity.
- 4.5.13.7 It is not recommended that entry deflection be generated by sharply deviating the approach road to the right and then to the left at entry. Approach curves should be fairly gentle, and adequately signed if they fall below the minimum standards appropriate to the design speed.

DIAGRAM 4.5.13.1 : ENTRY DEFLECTION BY STAGGERING APPROACH ROADS

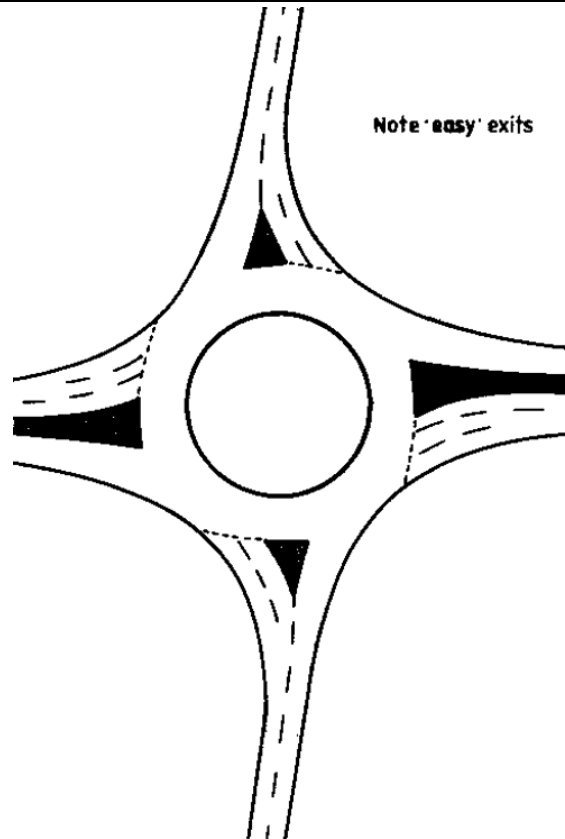
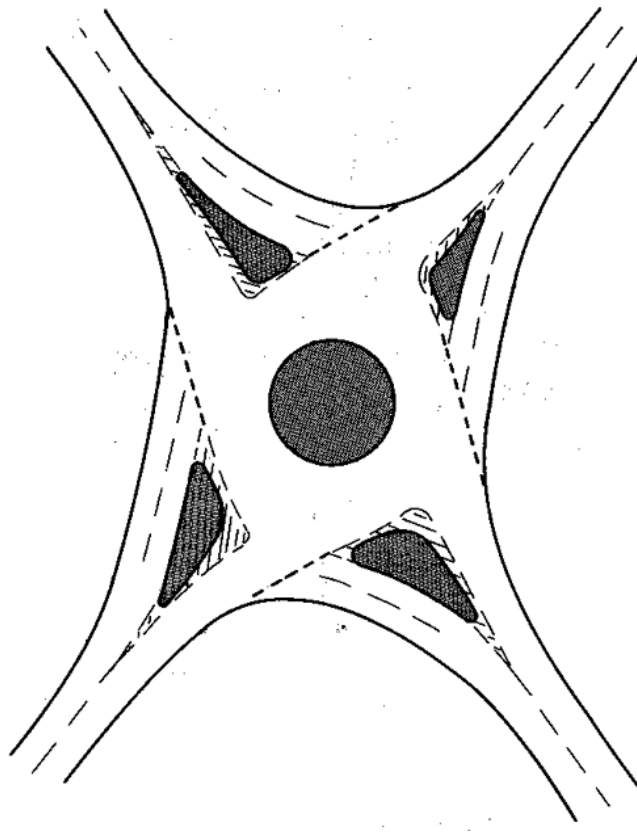
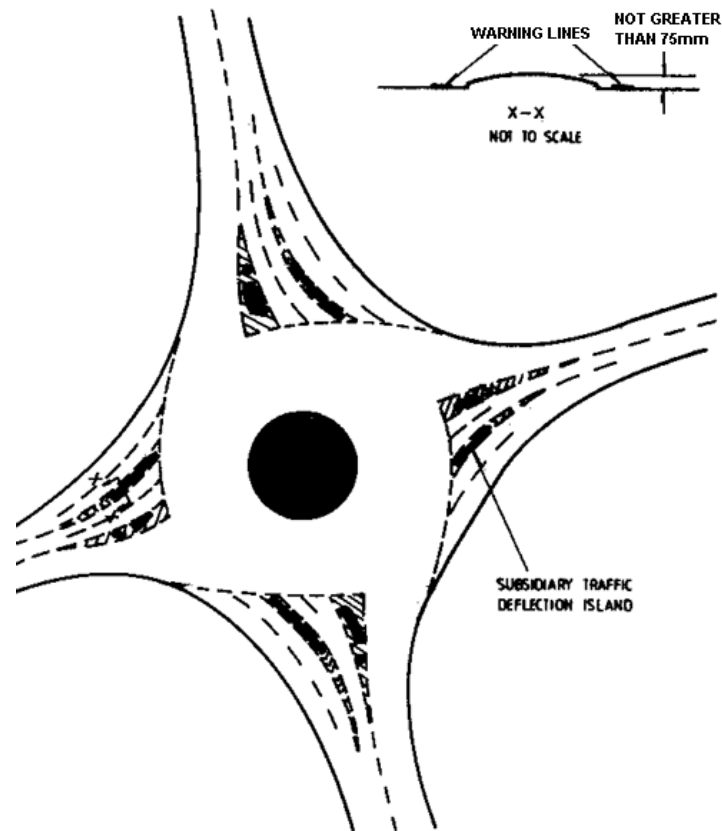

DIAGRAM 4.5.13.2 : ENTRY DEFLECTION ACHIEVED BY USING TRAFFIC DEFLECTION ISLANDS



**DIAGRAM 4.5.13.3 : ENTRY DEFLECTION ACHIEVED BY
SUBSIDIARY TRAFFIC DEFLECTION ISLANDS**



4.5.14 Roundabout Exits

- 4.5.14.1 A nearside kerb radius of about 40m at the mouth of the exit is desirable, but in any case this radius should not be below 20m.
- 4.5.14.2 The beginning of the exit should ideally be one lane wider than the downstream link. For example if the down stream link is a dual 2 the exit width should be 10m to 11m. The extra width should be reduced on the nearside at a taper of 1:15 to 1:20, though this may be extended on an uphill gradient to avoid intermittent congestion. Within single carriageway exits a minimum of 6m should be maintained throughout the length of any physical island to accommodate traffic passing a broken down vehicle.

4.5.15 The Circulatory Carriageway

- 4.5.15.1 The width of the circulatory carriageway should be constant and lie between 1.0 and 1.2 times the maximum entry width.
- 4.5.15.2 The circulatory carriageway should, if possible, be circular in plan, avoiding deceptively tight bends. Additionally, short lengths of reverse curve between entry and adjacent exit should be avoided by linking entry and exit curves or joining them with a straight. At T-junction configurations however, as shown in Diagram No. 4.5.12.2, reverse curvature may result.

4.5.16 Inscribed Circle Diameter

- 4.5.16.1 The inscribed circle diameter, as shown in Appendix 2 Fig. 1, should be large enough to accommodate the swept turning path of the design vehicle which may vary in accordance with the location and expected classes of traffic. Taking the worst case, a 16.0m long articulated vehicle with a single axle at the rear of the trailer, the smallest inscribed circle diameter for a conventional roundabout is 28m. If this cannot be accommodated, a mini roundabout should be used. It should be noted however that the requirements of adequate vehicle deflection at conventional/spiral roundabouts will generally dictate the minimum inscribed circle diameter.
- 4.5.16.2 Based on the design vehicle above, as a guide, the turning space requirements for conventional roundabout from 28m to 36m inscribed circle diameter are shown in Diagram. No. 4.5.16.1. For diameters greater than 36m the circulatory carriageway widths should be checked against Table 4.3.15.1 in the section on Priority Junctions.

DIAGRAM 4.5.16.1 : TURNING WIDTHS REQUIRED FOR SMALLER ROUNDABOUTS

IN THESE CASES NO ENTRY DEFLECTION ISLANDS SHOULD PROTRUDE WITHIN THE 1 CD

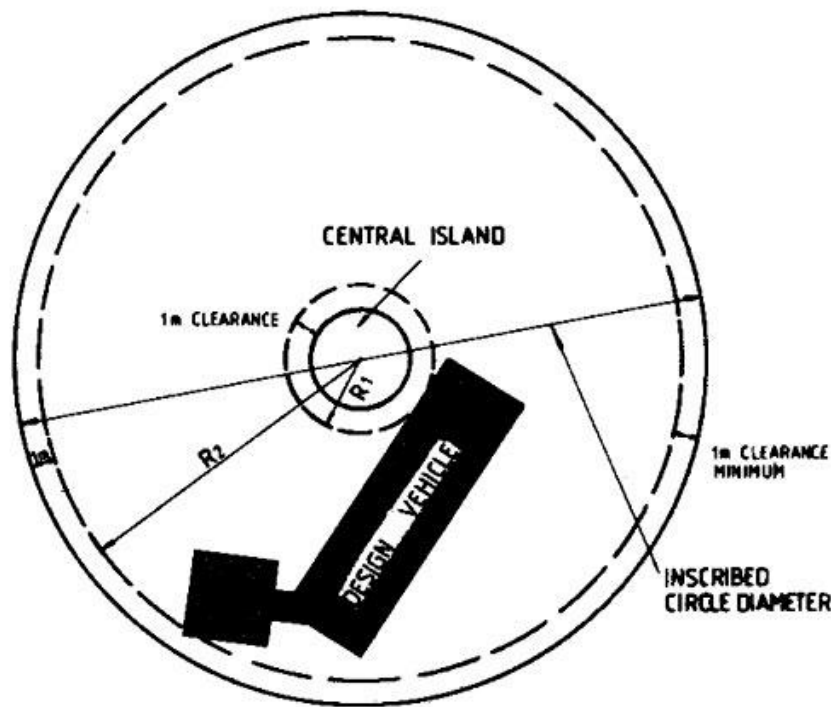

Central Island Diameter (m)	R1 (m)	R2 (m)	Minimum 1 CD (m)
4.0	3.0	13.0	28.0
6.0	4.0	13.4	28.8
8.0	5.0	13.9	29.8
10.0	6.0	14.4	30.8
12.0	7.0	15.0	32.0
14.0	8.0	15.6	33.2
16.0	9.0	16.3	34.6
18.0	10.0	17.0	36.0

4.5.17 Segregated Left Turning Lanes

- 4.5.17.1 Segregated left turning lanes should be considered when more than 50% of the entry flow, or more than 300 vehicles per hour in the peak hours, turn left at the first exit. For design purposes, a maximum capacity of 1800 pcu/hr may be assumed. Segregated left turning lanes should then be omitted from the calculation of entry capacity.
- 4.5.17.2 In segregated left turning lanes, vehicles are channelised into the left hand lane by lane arrows and markings, supplemented by advance direction signs, and vehicles proceed to the first exit without having to give way to others using the roundabout. Segregation by road markings and physical islands are shown in Diagram No. 4.5.17.1 and Diagram No. 4.5.17.2 respectively. The latter method requires more land take but it will not subject to abuse with better safety performance. The former method is less effective however because it is subject to abuse.
- 4.5.17.3 Segregated left turning lanes should be about 3.5m wide and not less than 3m. On smaller radius curves, widths should comply with the requirements set out in Table 4.3.15.1, but should not be so wide as to induce high speeds.
- 4.5.17.4 Where road markings are used to create the lane segregation double white lines (and may be with hatching in between) are appropriate for the purpose.
- 4.5.17.5 The merging between vehicles from a segregated left turning lane and other vehicles exiting from the roundabout should take place within 50m of the roundabout, where speeds are still comparatively low. Ideally there should not be a forced merge. However, running the two streams alongside each other is only possible where the exit link can provide two lanes in the same direction. In other cases, the segregated left turning traffic must merge with the other stream, giving way where necessary. This merging length should be at least 10m. Examples of typical urban situations are shown in Diagram Nos. 4.5.17.2 and 4.5.17.3.
- 4.5.17.6 Segregated left turning lanes should not be used when vehicular accesses to adjacent properties exist along the length of the lane.

DIAGRAM 4.5.17.1 : A SEGREGATED LEFT TURNING LANE USING ROAD MARKINGS

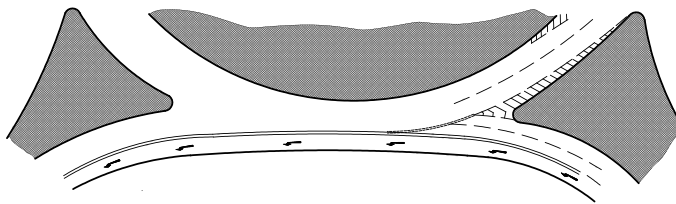
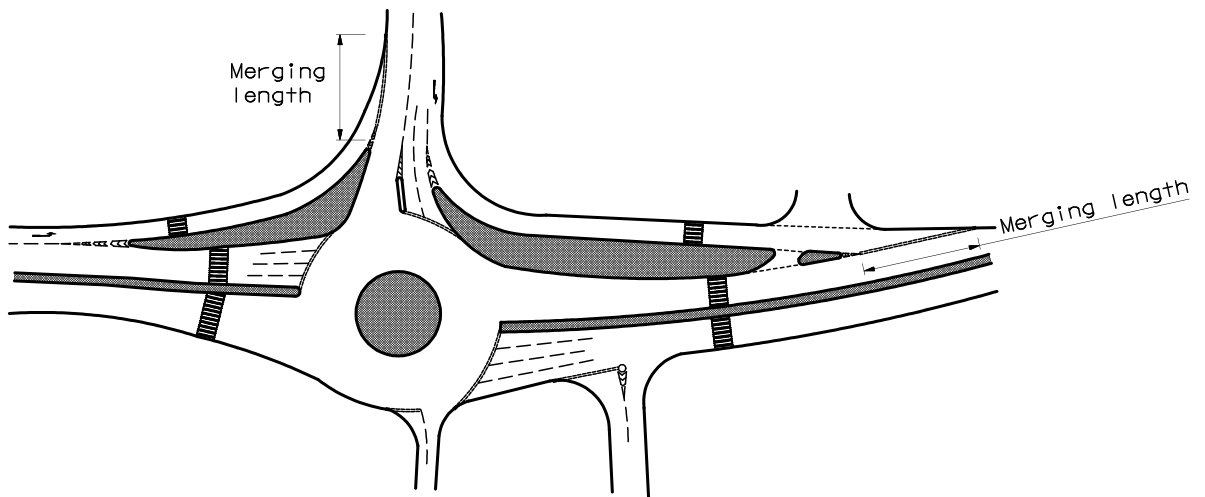
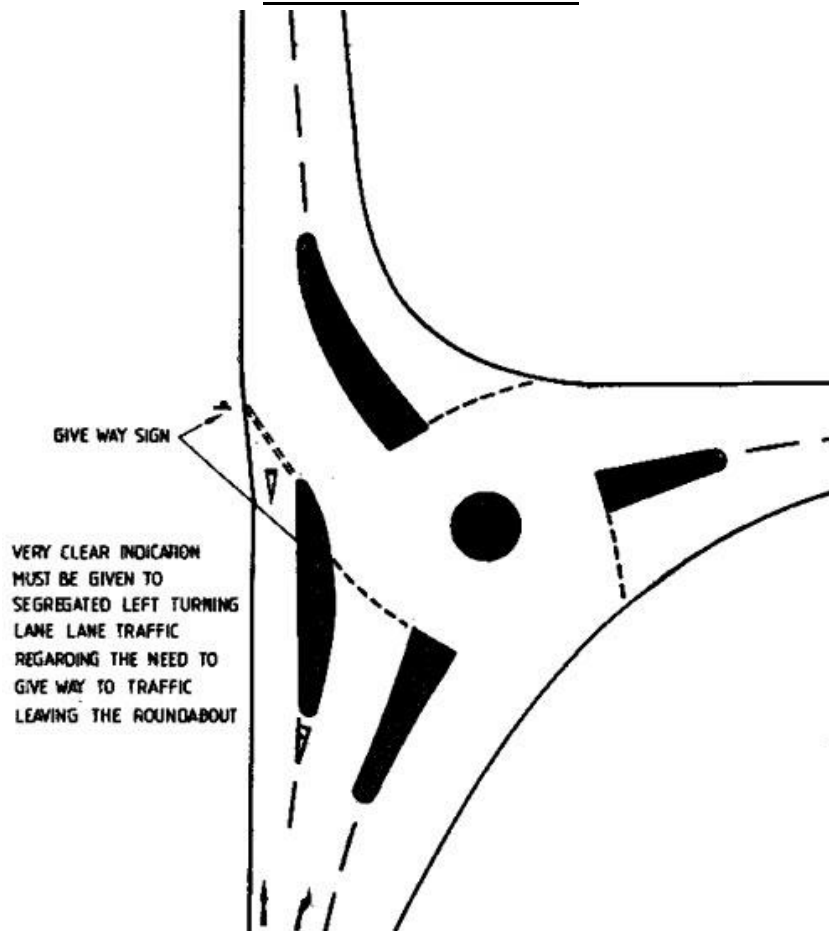

DIAGRAM 4.5.17.2 : PHYSICALLY SEGREGATED LEFT TURNING LANES



NOTE: This is not a recommendation but merely a specific example of the compromise needed in an urban situation. It was not possible to achieve desirable values of entry deflection because of adjacent development but the approaches have speed limits

DIAGRAM 4.5.17.3 : "STRAIGHT THROUGH" SEGREGATED LEFT TURNING LANE AT 3-WAY ROUNDABOUT



NOTE: This is not a recommendation, but merely a specific example showing the modification of a previous major / minor junction where it was not possible (because of site constraints) to provide desirable entry deflection on one approach. There are however speed limits on the approaches.

4.5.18 Superelevation and Crossfall

- 4.5.18.1 Superelevation is not required on the circulatory carriageways of roundabouts whereas crossfall is required, to drain surface water, but on the approaches and exits superelevation can assist drivers to negotiate the associated curves.
- 4.5.18.2 On entry, the degree of superelevation should be appropriate to the speed of vehicles, as they approach the roundabout, but should not exceed 5%. It should be reduced to the crossfall required merely for drainage in the vicinity of the "Give Way" line, since with adequate advance signing and entry deflection, speeds on the approaches should be sufficiently reduced.
- 4.5.18.3 On exits, superelevation may be provided to assist vehicles in accelerating away from the roundabout. However, as with entries, crossfalls adjacent to the roundabout should be kept to the minimum required for drainage.
- 4.5.18.4 Normal crossfall for drainage on roundabouts should be 2.0% and not exceed 3.0%. To avoid ponding, longitudinal edge profiles should be graded at not less than 0.67% desirable, and 0.5% absolute minimum.
- 4.5.18.5 On the circulatory carriageway, the values of crossfall should be governed by drainage requirements. However the direction of crossfall, particularly at conventional roundabouts and spiral roundabouts, should be arranged to assist circulating vehicles. Hence the carriageway adjacent to the central island should slope toward the central island while the carriageway adjacent to the outside perimeter will slope toward it. The crown line thus formed may be a straight line joining the entry and exit deflection islands or a line dividing the circulatory carriageway in the proportion 2:1 internal to external as shown in Diagram No. 4.5.18.1. Alternatively, a subsidiary crown line, as shown on Diagram No. 4.5.18.2, may be used to avoid excessive changes in crossfall at the single crownline. Maximum recommended algebraic difference in crossfall across the crown line is 5%, and lesser values are desirable.
- 4.5.18.6 Adverse crossfall should be eliminated from the paths of the main traffic movements at conventional roundabouts and spiral roundabouts. Mini roundabouts and smaller conventional/spiral roundabouts in urban areas are often superimposed upon existing pavement profiles and in these cases, the cross section of the existing roads will influence crossfalls at the roundabout. T-junctions require particular attention. Some adverse crossfall can be accepted in order to fit the existing levels provided approach speeds are low.

DIAGRAM 4.5.18.1 : CROSSFALL DESIGN USING ONE CROWN LINE

(a) JOINING TRAFFIC DEFLECTION ISLANDS

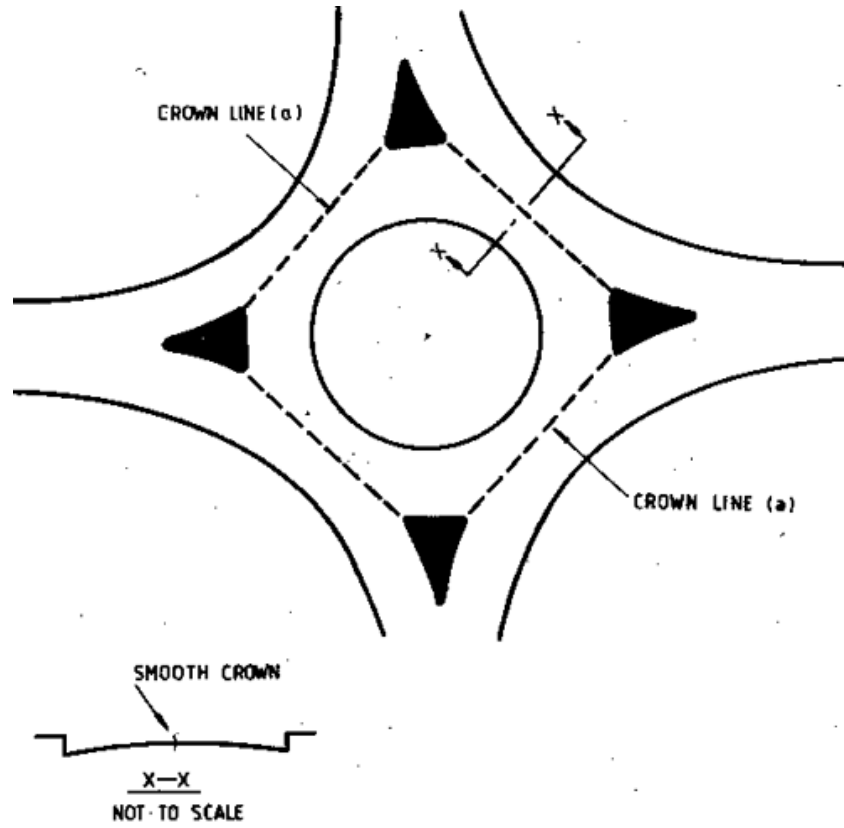

(b) DIVIDING CIRCULATORY CARRIAGEWAY 2 : 1

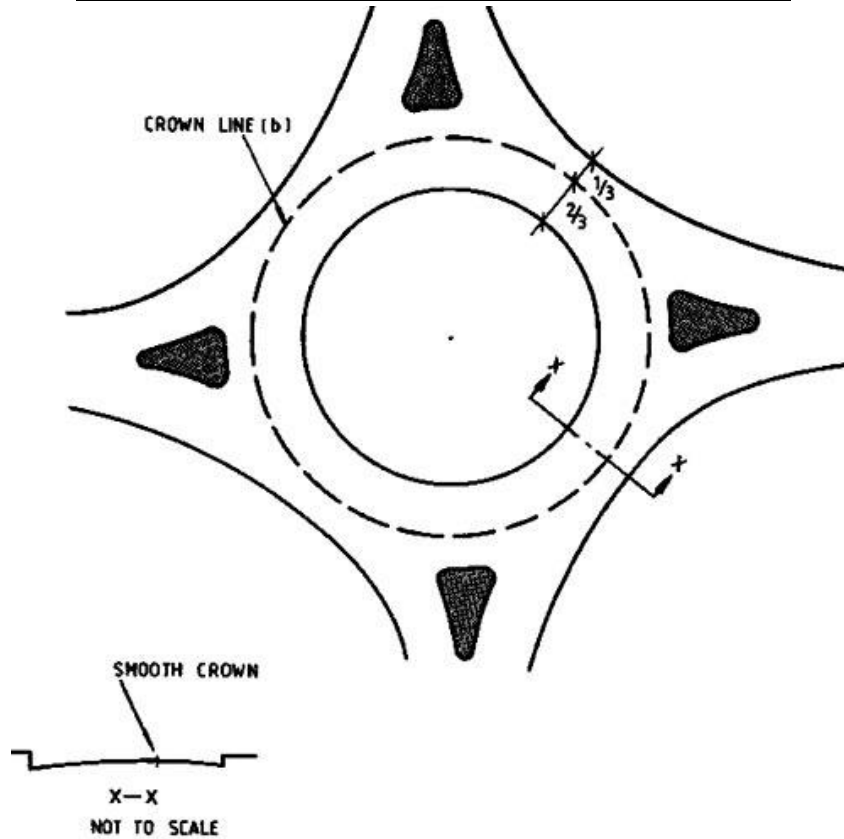
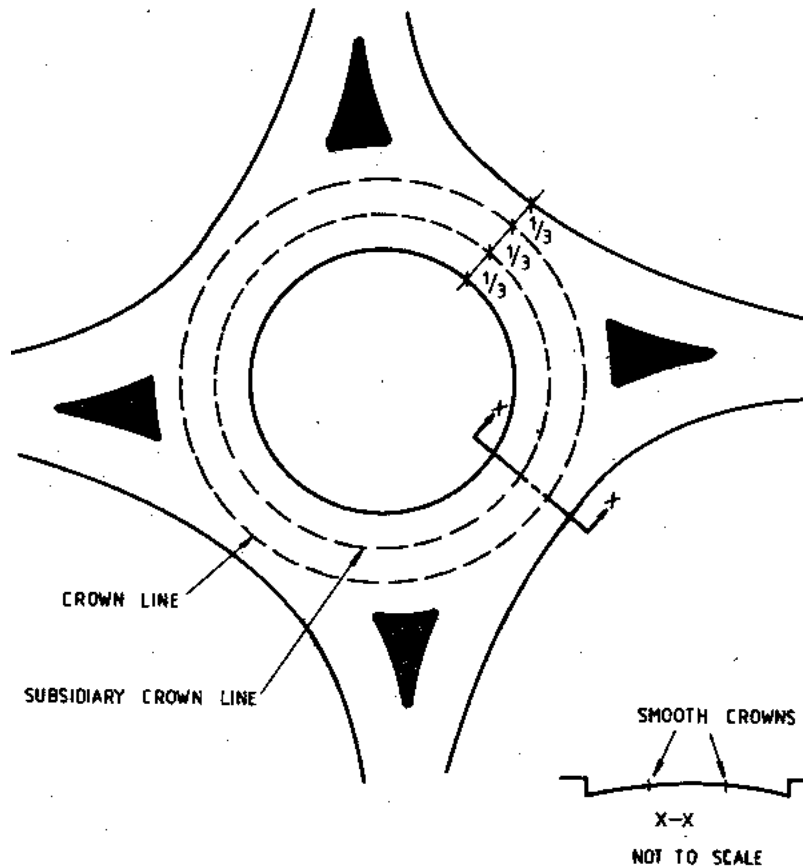

DIAGRAM 4.5.18.2 : CROSSFALL DESIGN USING TWO CROWN LINES**4.5.19 Signing and Lighting**

- 4.5.19.1 Design of signing and lighting should form an early part of the overall design process.
- 4.5.19.2 "Give Way" signs should be erected in association with the "Give Way" dotted lines at all roundabout approaches. The "Give Way" triangular marking is not required unless particular emphasis is required.
- 4.5.19.3 On the central island of conventional and spiral roundabouts, "Turn Left" signs and "Chevron" signs should be erected opposite each approach. These may be moved further to the left to emphasise the angle of turn and thereby encourage lower traffic speeds. At mini roundabouts, the central dome or circular marking should be free of all signs, lighting columns or other street furniture.
- 4.5.19.4 The "Roundabout Ahead" sign should be used on all approaches and may be supplemented with a "Reduce Speed Now" Plate, where high approach speeds are anticipated. "Count-down" markers and "Yellow Bar" markings are also effective in reducing speeds.
- 4.5.19.5 A map type advance direction sign should be used on the approaches of all roundabouts on major routes and can also prove beneficial on minor routes where the roundabout is of irregular shape.
- 4.5.19.6 Road markings should channelise traffic and where appropriate indicate a dedicated lane. Lane dedication should only be used at the entry of exclusive left-turn approach lane. Lane dedication arrows and double white lines on the circulatory carriageway are generally not recommended.
- 4.5.19.7 The provision of road lighting at roundabouts should be regarded as an essential safety requirement. When an existing roundabout junction is being modified, the lighting should be checked for suitability with the new road arrangement.
- 4.5.19.8 For detailed information on signing, Volume 3 of this Manual should be consulted.

4.5.20 Landscaping

- 4.5.20.1 Apart from the amenity benefits, the landscape treatment of roundabouts can have practical advantages from a traffic engineering point of view. By earth modeling, perhaps in conjunction with planting, the presence of the roundabout can be made more obvious to approaching traffic. The screening of traffic on the opposite side of the roundabout to the point of entry can, without restricting necessary visibility, avoid distraction and confusion caused by traffic movements of no concern to a driver. Planting can provide a positive background to chevron signs and direction signs on the central island while visually uniting the various vertical features and reducing any appearance of clutter.
- 4.5.20.2 Generally the planting of roundabout islands less than 10m in diameter is inappropriate as the need to provide driver visibility leaves only a small central area available. Such a restricted area of planting is out of scale with the roundabout as a whole, and becomes an incongruous "blob".
- 4.5.20.3 Any planting at the roundabout islands and adjacent to approaching arms should not impair visibility of motorists. Visibility requirements stated in Section 4.5.12 cannot be compromised for landscaping works design. Planting with excessive height should be sufficiently set back from the kerb line. Planting within visibility zone should be of slow growing species with minimal maintenance and should be less than 0.6m tall.

4.6 Grade Separated Junctions

4.6.1 Introduction

- 4.6.1.1 Grade separated junctions occur where some or all of the intersecting roads pass each other at different levels and some or all of the turning movements are catered for by ramps connecting the two levels.
- 4.6.1.2 Compared with other junction types, grade separated junctions offer increased capacity, less vehicular delay, fewer accidents and reduced operating costs. These benefits are offset by the high construction costs and usually increased land take. Land take, which is of prime importance in the vast majority of locations in Hong Kong, can however be minimised with prudent design. Junction layouts should be as compact as possible within the limitations imposed by the minimum geometric standards discussed in subsequent paragraphs.
- 4.6.1.3 The layouts and standards recommended in this section are most appropriate to trunk road and primary distributor junctions where most grade separated layouts may be expected.

4.6.2 Types of Grade Separated Junction

- 4.6.2.1 There are very many types of grade separated junction. The choice of a particular type in any situation will depend upon such factors as the relative status of the intersecting roads, the through route and turning traffic volumes and the site constraints. Some of the more common types of junction are shown on Diagram No. 4.6.2.1 and discussed below. The designer should however consider variations on these types or totally different layouts to best suit the particular conditions.
- 4.6.2.2 The Trumpet Interchange is a common layout at a T or Y junction and utilizes a single bridge structure carrying the minor road above the major road. It is most suitable where the loop movement is small and additional structures may be required to provide a better alignment for this movement where higher flows are involved.
- 4.6.2.3 The Diamond Interchange is the simplest type of 4-way junction consisting of a single bridge and four one way ramps. It is particularly suitable in the Territory as it can be located within a relatively narrow land area, requiring little extra width beyond that required for the major road itself. Linked traffic signals may be required at the junctions between the slip roads and the minor road.
- 4.6.2.4 The Roundabout Interchange requires two bridge structures and requires more land than the Diamond but has higher free flow capacity. It is hence more suitable when minor road/ramp conflicts are higher.
- 4.6.2.5 The Elevated Major Route includes those junctions where the major route is carried on bridge structure over the minor route. A basic principle in the design of grade separated interchanges is that the minor route should be carried above the major route. This is normally the more economical arrangement and has the distinct advantage of providing accelerating traffic with a down gradient and decelerating traffic with an up gradient. In the existing urban areas of the Territory however it has frequently been necessary to provide new major routes above the existing road network. This has led to numerous junctions with an elevated major route. The junction between the ramps and the minor road may be controlled by means of a roundabout or by signals.
- 4.6.2.6 The Cloverleaf Interchange is the only single structure 4-way interchange having no terminal right turns at-grade. Internationally it is perhaps the most common form of interchange, but its excessive use of land does not recommend it for adoption in the Territory. The other major drawback with this type of layout is the short weaving length between entry and exit ramps.

4.6.2.7

The Partial Cloverleaf Interchange is useful for accommodating a junction within a space constrained by existing development. The quadrant in which the ramps are located can be varied to suit the site restrictions.

DIAGRAM 4.6.2.1 : TYPES OF GRADE SEPARATED INTERCHANGE

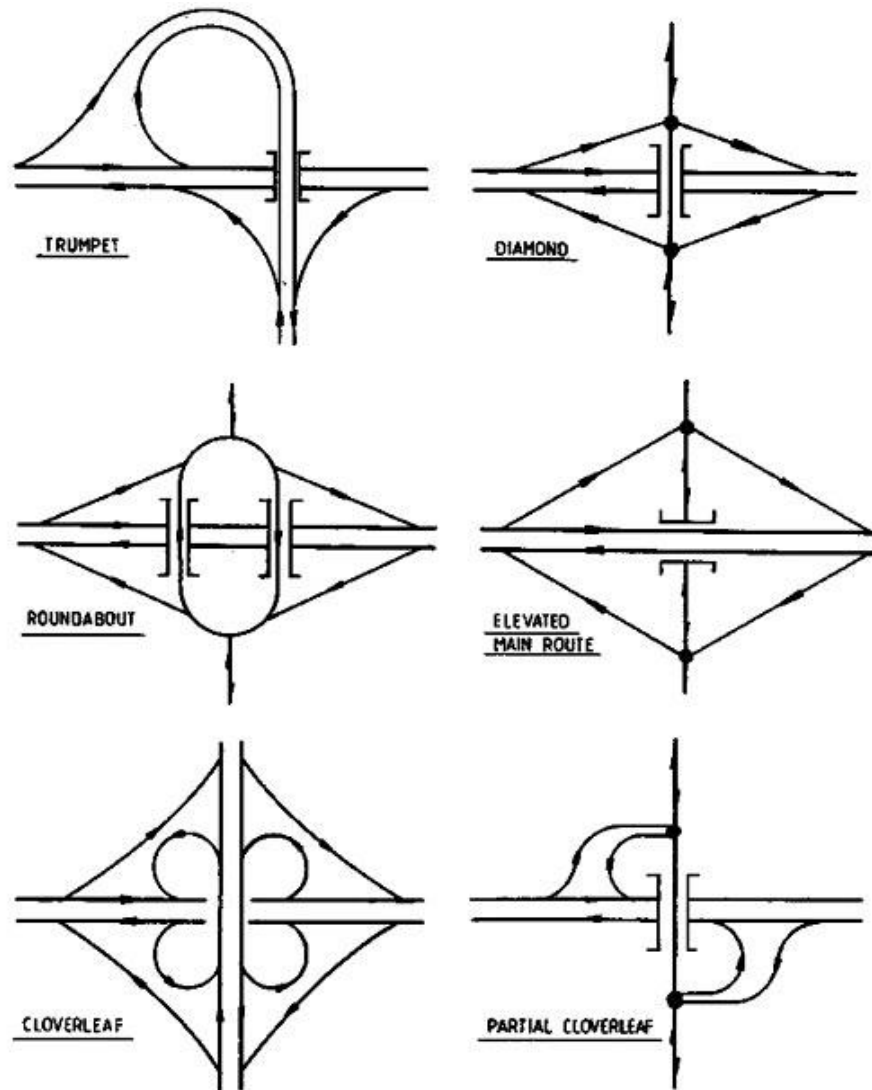

4.6.3 Siting of Grade Separated Junctions

4.6.3.1

Interchanges should not be sited where approach roads have long steep gradients which will materially slow heavy vehicles and cause them to bunch. For the same reason interchanges should also be avoided at the crest of hills where additionally, signing may be a problem as drivers attempt to read signs silhouetted against the skyline.

4.6.3.2

The siting of one interchange with respect to the adjacent ones will be governed by the requirements of minimum merging, weaving and diverging lengths as discussed in subsequent paragraphs.

4.6.3.3

In urban areas interchange location should take account of the effect of its elevated structures on adjacent development. To protect the privacy of occupants, it is recommended that elevated structures should not be constructed closer than 20m to residential buildings. The nuisance caused by fumes, noise and visual intrusion should also be taken into account and minimized. For the operation of fire service appliances a minimum of 6m is required between elevated structures and all adjacent buildings.

4.6.4 Capacity of Grade Separated Junctions

4.6.4.1 The capacity of a grade separated interchange is governed by the capacity of the individual merging, diverging and weaving sections within that interchange. Based on limiting values of main line flow, link flow and merging, diverging or weaving capacities, standard layouts are recommended which can cater for different combinations of major and minor route design flows. The method by which design flows are derived, and then applied to produce a layout with adequate capacity, is covered separately for merging lanes, diverging lanes and weaving sections under those respective headings, in subsequent paragraphs.

4.6.5 General Layout Requirements

4.6.5.1 Interchanges should be designed to cater primarily for the major flows, with the through movements maintaining the design speed selected for the through route between junctions. Geometric parameters relating to turning movements should reflect the magnitude of design flow for that movement.

4.6.5.2 Generous curvature, in for example 270° loops, can be wasteful in land and capital costs and will not necessarily lead to low operating costs, for the extra distance traveled at high speed might outweigh slower speeds on a shorter tighter loop.

4.6.5.3 Decision points should be separated as much as possible and the number of decision points in any one sequence kept to a minimum.

4.6.5.4 Consideration should be given to bus routes operating on the major road to identify the need for bus stopping facilities within or adjacent to the interchange.

4.6.6 Visibility

4.6.6.1 Visibility distances are related to the design speed of the road as shown in Table 4.6.6.1.

Table 4.6.6.1
Visibility Distance at Grade Separated interchanges

<u>Design Speed(km/h)</u>	<u>Desirable Minimum(m)</u>	<u>Absolute Minimum(m)</u>
120	300	225
100	225	165
85	165	125
70	125	95
60	95	70
50	70	50
40	50	40
30	40	30

4.6.6.2 Forward visibility at the merge or diverge should be similar to that on the mainline, but once on the link road the visibility standards applicable to that route apply.

4.6.6.3 Sideways visibility is particularly important at the merge section and this is provided by a long merge nose which is shown on the merging layouts as 60m, which should be considered as minimum.

4.6.6.4 The minimum length of diverge nose is 40m. The vertical alignment of the diverge link beyond the nose should be readily visible to traffic in the diverging lane so that drivers can assess the speed value in advance.

4.6.7 Slip Roads

4.6.7.1 The design speed on the slip road will generally be lower than the design speed on the main line and hence the need for acceleration and deceleration lanes. The discrepancy in speeds however should not be so great as to hinder the safe and efficient transfer between the two. Table 4.6.7.1 shows the minimum slip road design speed for various main line design speeds and the corresponding slip road minimum curve radii.

Table 4.6.7.1
Minimum Slip Road Design Speed and Curve Radii

<u>Main Line Design Speed(km/h)</u>	<u>Slip Road Design Speed(km/h)</u>	<u>Slip Road Curve Radii</u>	
		<u>Desirable Minimum(m)</u>	<u>Absolute Minimum(m)</u>
120	80	230	115
100	60	125	63
85	50	88	44
70	40	60	35
60	30	40	30
50	25	30	25

4.6.7.2 Slip roads may be single lane or two lane depending on the traffic volume. In both cases the slip road width will vary in relation to the curve radii.

4.6.7.3 The overall width of any ramp or slip road will be determined by the effective carriageway width plus the width required for the parapets on either side.

4.6.7.4 The effective carriageway width is that occurring between the inside foot of the parapet, or any kerb face if this is provided, on either side of the slip road or ramp, as shown for a single lane slip road in Diagram 4.6.7.1.

**DIAGRAM 4.6.7.1 : EFFECTIVE CARRIAGEWAY WIDTHS OF SINGLE LANE RAMPS
AND SLIP ROADS**

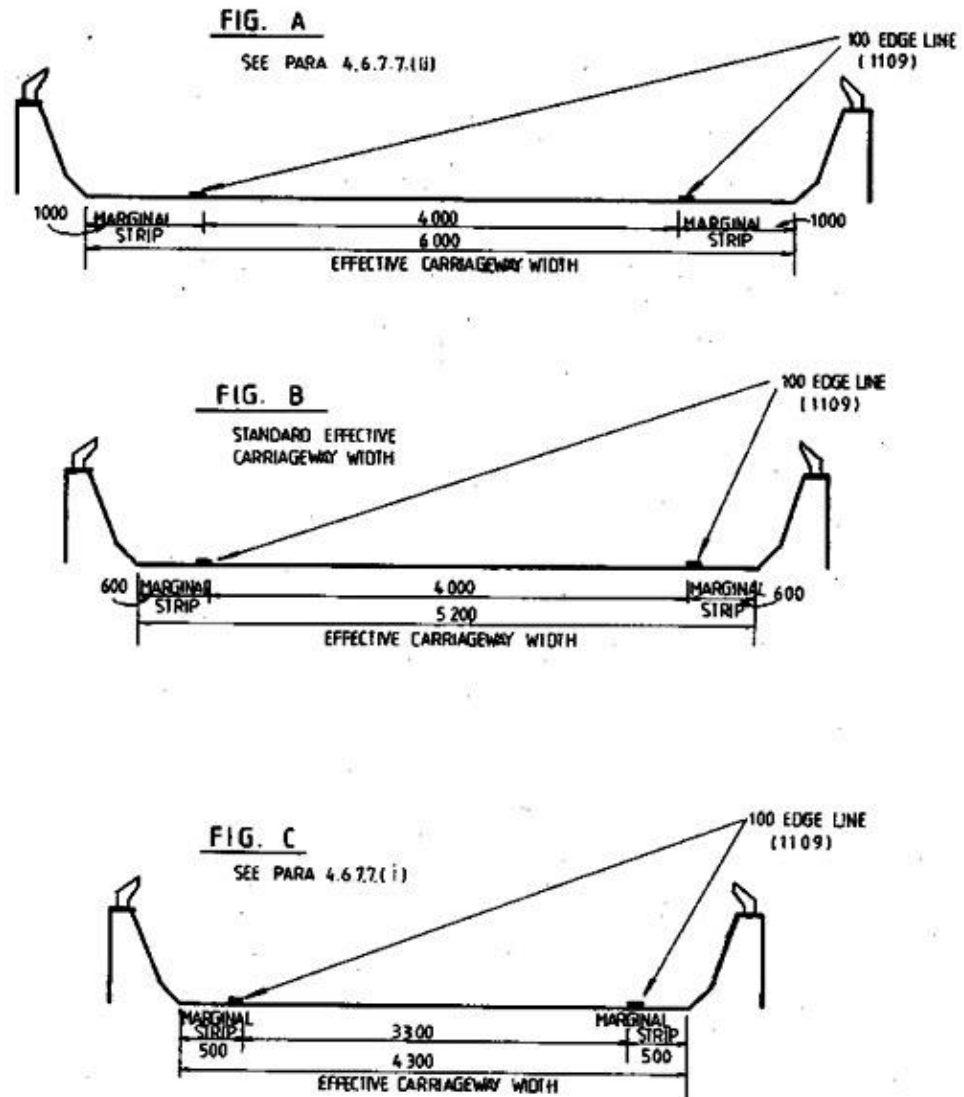

NOTE: ALL DIMENSIONS IN MILLIMETRES

- 4.6.7.5 The effective carriageway width shall include marginal strip of appropriate width in accordance with Diagram 4.6.7.1 for single lane slip roads and paragraph 4.6.7.12 for two lane slip roads. The marginal strips must be delineated by a 100mm continuous edge line marking, as illustrated in Diagram 4.6.7.1.
- 4.6.7.6 The standard effective carriageway width for single lane ramps or slip roads is 5.2m, subject to paragraph 4.6.7.11.

- 4.6.7.7 Effective carriageway widths other than the standard effective carriageway width should be considered in accordance with the following guidelines :-
- (i) Where the combined, Heavy Goods Vehicle, Medium Goods Vehicle, Bus and Coach traffic flow is predicted to be less than 5% of the design year AADT flow, subject to paragraphs 4.6.7.8, 4.6.7.9 and 4.6.7.11, the effective carriageway width may be reduced to 4.3m; or
 - (ii) Where the combined, Heavy Goods Vehicle, Medium Goods Vehicle, Bus and coach traffic flow is predicted to be greater than 10% of the design year AADT flow, subject to paragraph 4.6.7.11, the effective carriageway width shall be increased to 6m, except that where very high costs may arise, the standard effective carriageway width of 5.2m may be provided. However it will be necessary in this case to substantiate the savings that would be obtained, and provide details of the implications of adopting 5.2m rather than 6m.
- 4.6.7.8 It should be noted that the 5.2m width will allow a goods vehicle to pass a stationary car, but in the event of a goods vehicle or bus breaking down it is unlikely that another goods vehicle or bus would be able to pass the broken down vehicle. Similarly, whilst the 4.3m width will allow a car to pass another stationary car, it is unlikely that a goods vehicle or bus could pass the same stationary car. Therefore when contemplating the use of an effective carriageway width less than 6m, consideration should be given as to whether on the particular single lane ramp or slip road there is for any reason likely to be a higher breakdown incidence than normal, the effects of which might be worsened if a too narrow width was adopted. Consideration must also be given to the availability of alternative routes which could be used to by-pass the obstruction. The Public Transport Planning Division of the Transport Department should be consulted to ascertain whether there is any likelihood of a bus route being required at any time in the future, which might be prejudiced if an inadequate operational width was provided.
- 4.6.7.9 Where single lane ramps or slip roads are greater than 50m in length the effective carriageway width should not normally be less than 5.2m.
- 4.6.7.10 Where single lane ramps or slip roads are greater than 100m in length the Traffic Control and Surveillance Division of the Transport Department should be consulted to ascertain whether surveillance measures need to be included in the scheme.
- 4.6.7.11 To ensure adequate clearance between any vehicle and the parapets, and to maintain the passing requirements mentioned in paragraph 4.6.7.8 the effective carriageway widths should be widened on curves in accordance with Table 4.6.7.2.
- 4.6.7.12 The width of two lane slip roads is based on the need to maintain two lanes of moving traffic whilst providing sufficient horizontal clearance between vehicle and parapet. The effective carriageway width should be 8.75m or 7.75m comprising a 6.75m carriageway and two marginal strips which should each be 1m wide on Rural Trunk Roads and 500mm in width on other roads. As with single lane slip roads the effective width should be maintained through curves by appropriate widening as shown in Table 4.6.7.2. The desirable minimum standard in this Table is based on the requirements of a 16.0m articulated vehicle. Absolute minimum values are also given but these should not normally be used and in any case not used on bus routes and in situations with more than the minimum volumes of medium and heavy goods vehicles. Both desirable minimum and absolute minimum values include two marginal strips each one metre wide and the effective width should be correspondingly reduced if 500mm marginal strips are used.
- 4.6.7.13 For both two lane and single lane slip roads, where widening is provided through curves the marginal strips should be maintained at the same width as those on the approach to the curve.

Table 4.6.7.2
Minimum Effective Carriageway Widths on Slip Roads
Related to Inside Radius of Curve (m)

Inside Radius of curve (m)	Single Lane Slips (Including Marginal Strips)			Two Lane Slips (Including Two 1 m Marginal Strips)	
	6m Effective Carriageway Width	5.2m Standard Effective Carriageway Width	4.3m Effective Carriageway Width	Desirable Minimum (m)	Absolute Minimum (m)
	Width on Curve (m)	Width on Curve (m)	Width on Curve (m)		
15	n/a	n/a	7.1	n/a	n/a
20	n/a	n/a	6.2	n/a	n/a
25	8.2	6.8	5.7	12.9	10.5
30	7.8	6.4	5.3	12.3	10.2
40	7.2	5.8	4.7	11.3	9.9
50	6.9	5.6	4.3	10.7	9.7
75	6.5	5.4	4.3	10.0	9.4
100	6.3	5.2	4.3	9.6	9.3
150	6	5.2	4.3	9.3	9.0
Straight	6	5.2	4.3	8.75	8.5

4.6.7.14 Recommended limiting gradients on slip roads are shown in Table 4.6.7.3. Where a high percentage of heavy vehicles is expected in the design year greater effort should be made to achieve the desirable maximum.

Table 4.6.7.3
Recommended Limiting Gradients on Slip Roads

Type of Route	<u>Desirable Maximum</u>	<u>Absolute maximum</u>
Trunk Roads, Primary Distributors and Bus Routes	4%	8%
Others	5%	10%

4.6.8 Merging Lanes

- 4.6.8.1 The recommended standards for merging lanes are based on a main line operating speed of 80 km/h, which seems the most appropriate for those roads in the Territory which will utilize grade separated junctions. The recommended layouts may be adopted for lower or higher speeds however with suitable adjustment to the proposed standards.
- 4.6.8.2 In normal circumstances the direct entry, i.e. where the merging lane joins the main road via a straight taper, is preferred. Situations will occur however where a more generous layout, including a parallel merging lane plus taper, will be justified by difficult site conditions as discussed in paragraph 4.6.8.5. Both layouts are depicted in Diagram No. 4.6.8.1.
- 4.6.8.3 For the direct entry merging lane a taper of 1 : 30 is recommended. For single lane entries however this should be increased to 1 : 40 wherever possible.
- 4.6.8.4 The length of merge nose should be a minimum of 60m to provide adequate sideways visibility for merging traffic.

4.6.8.5 As stated in paragraph 4.6.8.2 an additional length of parallel merging lane may be required in the following types of conditions :-

- (i) Where the main line is on a significant left hand curve. In this case visibility is limited and the direct entry is not so effective as the angle of convergence is too great. By providing a length of parallel lane, drivers are able to observe conditions on the main line by using their driving mirrors rather than turning their heads.
- (ii) Where the main line and hence the merging lane is on a steep upgrade. Here the problem is one of matching speeds and a greater distance is required by merging vehicles in which to accelerate.
- (iii) Where the main line is on a steep down gradient there may also be problems associated with the high speed of vehicles in the near side lane.

In these situations an additional merging lane 3.7m wide and a minimum of 100m long with a 70m taper should be provided.

4.6.8.6 At higher entry flows two merging lanes may be required and the resulting layout may be of the direct or shadow island type. Both types of layout are depicted; Diagram No. 4.6.8.2 illustrating the situation with a consistent number of lanes on the main line, and Diagram No. 4.6.8.3 showing the case where there is a pick up of one lane after the junction.

4.6.8.7 The method of deciding on the appropriate merging lane layout, which will provide the required capacity to cater for the design flows, is described in the following paragraphs. It should be remembered however that the layout thus recommended may need adjusting through outside influences such as a policy decision to provide the same number of lanes throughout the whole main line route, for example.

4.6.8.8 Design year flows in vehicles per hour should be obtained for the main line and the entry link. The worst combination of these flows, allowing for possible different timing of peaks, is then used as a base. The base flows are then adjusted for non-standard combinations of traffic composition and gradient as indicated in Table 4.6.8.1. The gradient should be measured over a one kilometer section of the main line, centred on the merge nose.

Table 4.6.8.1
Percentage Corrections to Predicted Flow for
Non-standard Composition and Gradient

Gradient on Main Line	Percentage of Heavy Vehicles on Link or Main Line - Being Considered							
	<u>5</u>	<u>10</u>	<u>15</u>	<u>20</u>	<u>25</u>	<u>30</u>	<u>35</u>	<u>40</u>
Downhill, Level or 1% Up	-8	-4	0	+4	+8	+12	+16	+20
1% - 2% Uphill	+2	+6	+10	+14	+18	+22	+26	+30
2% - 3% Uphill	+12	+16	+20	+24	+28	+32	+36	+40

4.6.8.9 The design year flows in v.p.h., adjusted as above, are then plotted on Diagram No. 4.6.8.5 to identify a flow region, which is indicated alphabetically.

4.6.8.10 Having identified the flow region to which the adjusted design year flows correspond, Table 4.6.8.2 should be consulted to find out which merging layout types are suitable to provide the required capacity. The layout types most likely to be appropriate are indicated with an asterisk. Where flow combinations are close to boundaries between different flow regions, the layout types indicated for the adjacent flow region should also be considered.

Table 4.6.8.2
Type of Merging Layout Appropriate to Flow Region

		<u>Merging Lane Type</u>								
		<u>1</u>	<u>2</u>	<u>3</u>	<u>4</u>	<u>5</u>	<u>6</u>	<u>7</u>	<u>8</u>	<u>9</u>
Number of Lanes	Upstream Main Line	2	2	2	3	3	3	2	2	3
	Link	1	2	2	1	2	2	1	2	1
	Downstream Main Line	2	2	3	3	3	4	3	4	4
Flow Region	A	*			*			*		
	B				*			*		
	C				*			*		
	D			*	*	*		*		
	E			*	*		*		*	
	F						*		*	
	G				*					*
	H				*		*			*
	I				*		*			*

- 4.6.8.11 The merging lane types are shown in Diagram Nos. 4.6.8.1, 2, 3, and 4 and the following notes on each type should also be considered in deciding upon the appropriate layout.
- 4.6.8.12 Types 1 + 4 (Diagram No. 4.6.8.1)
The direct entry is the most economical merging layout for single lane links. It will cater for entry flows up to approximately 1000 v.p.h. after correction, but should only be used under favourable site conditions. Where the main line is situated on a left hand curve, where the main line is on a gradient or where for other reasons it is necessary to provide greater definition of the merging lane, the more generous parallel type merging lane layout should be adopted.
- 4.6.8.13 Types 2 + 5 (Diagram No. 4.6.8.2)
The direct entry layout is suitable for the higher entry flows near the limit of a single lane entry but where diverse geometric conditions render a single lane entry unsuitable. The shadow island merging layout is the more normal and preferred layout where entry flows dictate a two lane entry and where there is not the need for the addition of an extra lane downstream. The layout permits the right hand traffic on the link to enter the main line early and to dissipate to form gaps for the second merging lane. Both layouts can accommodate a single lane link, widened to a two lane entry, where appropriate.
- 4.6.8.14 Types 3 + 6 (Diagram No. 4.6.8.3)
Where an extra lane is required for downstream traffic these layouts are appropriate. The parallel entry layout gives the left hand lane of the link free entry while the right hand lane of the link merges with the slower traffic on the main line. The shadow island entry, on the other hand, provides free entry for the faster traffic on the link and subsequent merging of the slower traffic and is to be preferred for the higher ranges of traffic in this category. The shadow island entry is also preferred on left hand curves and uphill links. In both layouts the slower moving traffic on the main line must eventually merge into the nearside lane, but there is no immediate necessary to do so.
- 4.6.8.15 Types 7, 8 + 9 (Diagram No. 4.6.8.4)
Types 7 + 9 are appropriate on routes where lane drop/pick up interchanges are used. Type 8 is more appropriate in the situation where two routes of equal status and carrying equal volumes of traffic meet. Experience has shown that it is advisable to present immediate weaving by the use of double white lines and the length of such lines though varying with site conditions should be at least 50m.

DIAGRAM 4.6.8.1 : MERGING LANES (DESIGN SPEED 80 km/h)
DIRECT ENTRY MERGING LANE (TYPES 1 + 4)

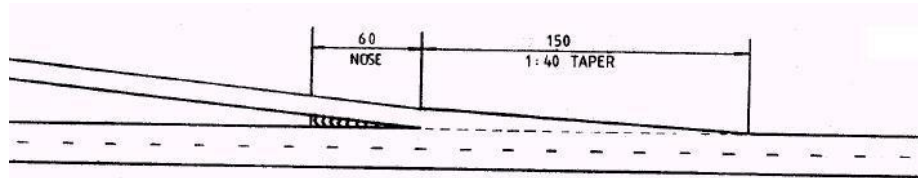

PARALLEL MERGING LANE (TYPES 1 + 4)

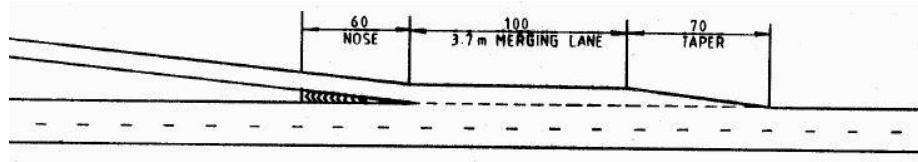
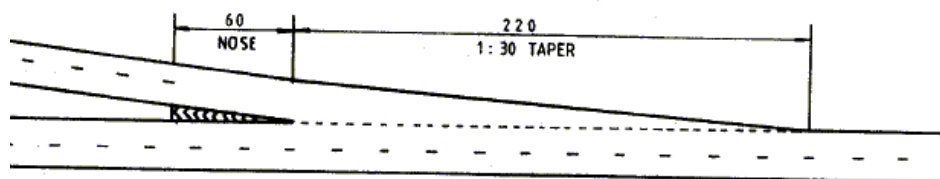

DIAGRAM 4.6.8.2 : MERGING LANES (DESIGN SPEED 80 km/h)
DIRECT ENTRY MERGING LANE (TYPES 2 + 5)



TYPE 1 SINGLE LANE LINK TO TWO LANE MAIN LINE

TYPE 4 SINGLE LANE LINK TO THREE LANE MAIN LINE

NOTE: ALL DIMENSIONS IN METRES

SHADOW ISLAND MERGING LANE (TYPES 2 + 5)

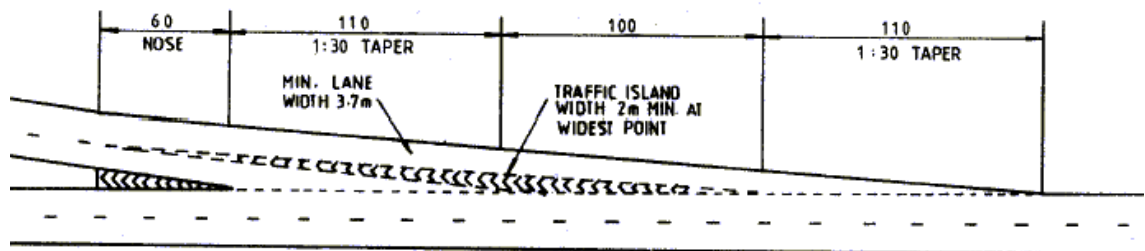

TYPE 2 TWO LANE LINK TO TWO LANE MAIN LINE

TYPE 5 TWO LANE LINK TO THREE LANE MAIN LINE

NOTE: ALL DIMENSIONS IN METRES

DIAGRAM 4.6.8.3 : MERGING LANES (DESIGN SPEED 80 km/h)
DIRECT ENTRY MERGING LANE (TYPES 3 + 6)

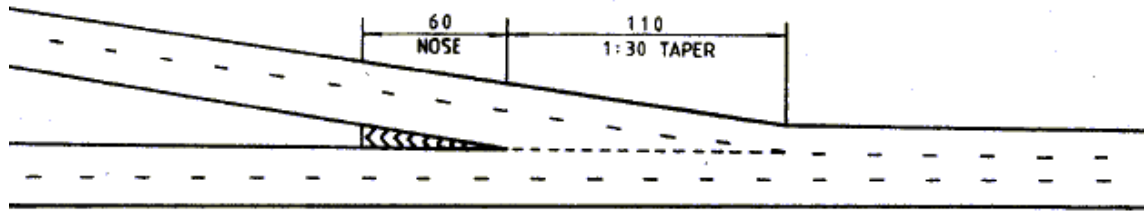

SHADOW ISLAND MERGING LANE (TYPES 3 + 6)

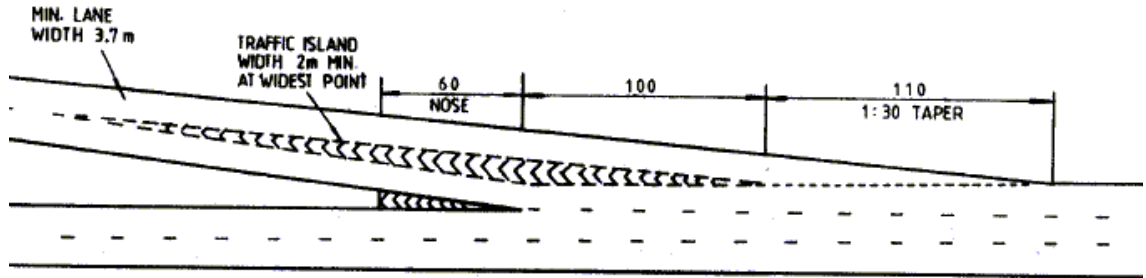

TYPE 3 TWO LANE LINK - MAIN LINE TWO INCREASING TO THREE

TYPE 6 TWO LANE LINK - MAIN LINE THREE INCREASING TO FOUR

NOTE: ALL DIMENSIONS IN METRES

DIAGRAM 4.6.8.4 : MERGING LANES (DESIGN SPEED 80 km/h)
ADDITIONAL LANE - NO IMMEDIATE MERGING (TYPES 7 + 9)

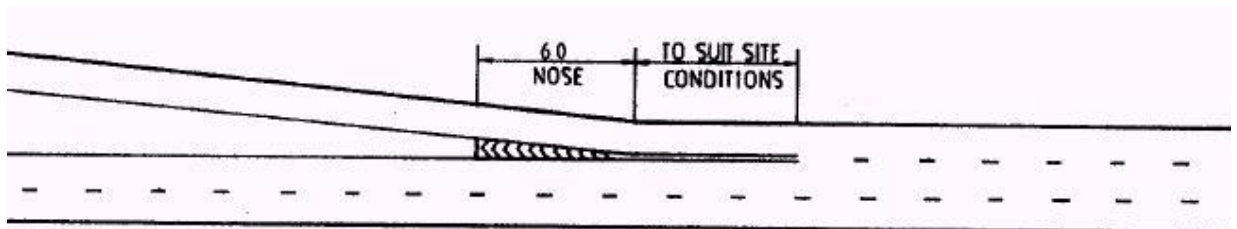

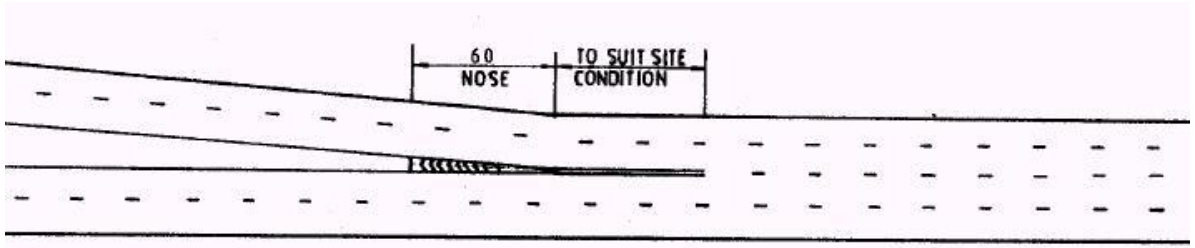
ADDITIONAL LANES - NO IMMEDIATE MERGING (TYPE 8)

- TYPE 7 SINGLE LANE LINK - MAIN LINE TWO INCREASING TO THREE
- TYPE 8 SINGLE LANE LINK - MAIN LINE THREE INCREASING TO FOUR
- TYPE 9 TWO LANE LINK - MAIN LINE TWO INCREASING TO FOUR

NOTE: ALL DIMENSIONS IN METRES

**DIAGRAM 4.6.8.5 : MERGING DIAGRAM
(INDICATING APPROPRIATE FLOW REGION)**

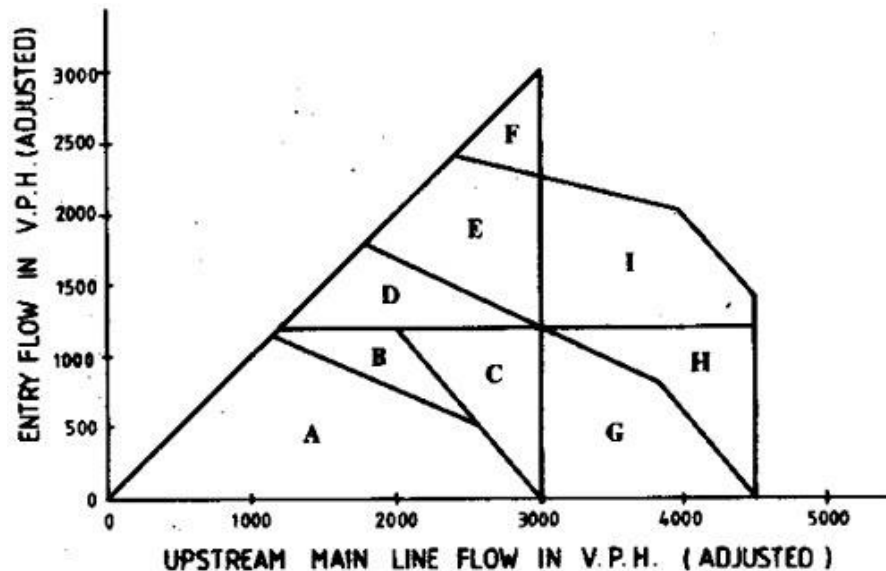

4.6.9 Diverging Lanes

- 4.6.9.1 As with merging lanes (see para. 4.6.8.1) a main line operating speed of 80 km/h has been used in arriving at the recommended standards.
- 4.6.9.2 The direct diverging lane, i.e. where the diverging lane exits via a straight taper, is to be preferred under normal site conditions. The diverge taper shall be 1:20 except that 1:35 should be adopted, to give additional space for diverging traffic, at single lane links or at two lane links where one lane is dropped from a three lane main line.
- 4.6.9.3 The length of diverge nose should be a minimum of 40m.

4.6.9.4 More generous diverging layouts may be required under the following adverse site conditions : -

- (i) If the main line is on a significant right hand curve, a direct taper would result in a tangential alignment and would be confusing to drivers.
- (ii) If the main line is on a steep upgrade a longer distance is needed for the diverging manoeuvre, to enable faster vehicles approaching in the outer lanes to penetrate through those heavy vehicles which are moving slowly in the left hand lane.
- (iii) When the main line is on a steep downgrade a problem may arise associated with the high speed of vehicles on the main line left hand lane.

In these situations an extra diverging lane 3.7m wide and at least 100m long with a 70m taper should be provided.

4.6.9.5 To decide upon the most appropriate diverging lane layout to accommodate design year flows, a method is employed which is the same as that used for merging lanes. Again it should be emphasized however that the method described in subsequent paragraphs indicates the most suitable layout for a diverge considered in isolation. The other junctions along the main line route should also be considered, so that drivers may be presented with a consistent set of layout features.

4.6.9.6 The main line and link flows should be assessed in terms of v.p.h. in the design year and the worst combination of these flows, taking account of different peak periods, used as a base. The base flows should then be adjusted for non standard traffic composition and gradient as shown in Table 4.6.8.1. The gradient should be measured over a distance of one kilometre, centred upon the nose of the diverge lane.

4.6.9.7 The design flows in v.p.h. adjusted as above, should then be plotted on Diagram No. 4.6.9.1 to identify the appropriate flow region, indicated alphabetically.

4.6.9.8 Using Table 4.6.9.1 the appropriate types of layout, suitable for handling the flow region assessed as above, are identified. The diverging lane types indicated by an asterisk are likely to prove the most acceptable in terms of level of service. Where flow combinations are close to boundaries between different flow regions, the layout types indicated for the adjacent flow region should also be considered.

Table 4.6.9.1
Type of Diverging Layout Appropriate to Flow Region

		<u>Diverging Lane Type</u>								
		<u>1</u>	<u>2</u>	<u>3</u>	<u>4</u>	<u>5</u>	<u>6</u>	<u>7</u>	<u>8</u>	<u>9</u>
Number of Lanes	Upstream Main Line	2	2	3	3	3	4	3	4	4
	Link	1	2	1	2	2	2	1	1	2
	Downstream Main Line	2	2	3	2	3	3	2	3	2
Flow Region	P	*	*	*				*		
	Q			*				*		
	R			*					*	
	S			*	*	*	*			*
	T			*			*			*
	U			*			*		*	
	V			*			*		*	

4.6.9.9 The diverging lane types are shown in Diagram Nos. 4.6.9.2, 3, 4, and 5. In conjunction with Table 4.6.9.1 the following notes on each layout type should be considered in deciding upon the most appropriate layout.

4.6.9.10 Types 1 + 3 (Diagram No. 4.6.9.2)

The direct diverging lane is the most economical layout for single lane links and is appropriate up to flows of approximately 1000 v.p.h. after correction and where site conditions are favourable. Where the diverge is situated on a right hand curve, or where the intersection is on a gradient, the parallel diverging lane layout is more appropriate.

4.6.9.11 Types 2 + 5 (Diagram No. 4.6.9.3)

The direct diverging lane layout is appropriate for exiting flows around the limit of the single lane exit but where site conditions do not favour a single lane. The standard layout where two exit lanes are required, and where there is no lane drop, is shown in the parallel diverging lane layout. The parallel diverging lane layout is particularly preferred when the diverge is situated on a right hand curve.

4.6.9.12 Types 4 + 6 (Diagram No. 4.6.9.4)

Where a lane is dropped at the intersection types 4 + 6 layout are appropriate. The direct diverging lane may be used in favourable site conditions, whereas the parallel type layout is more appropriate on right hand curves.

4.6.9.13 Types 7, 8 + 9 (Diagram No. 4.6.9.5)

Types 7 and 8 are appropriate along routes with lane drop/pick up at interchanges. Type 9 may be used at the divergence of two routes of equal importance and carrying equal volumes of traffic.

DIAGRAM 4.6.9.1 : DIVERGING DIAGRAM
(INDICATING APPROPRIATE FLOW REGION)

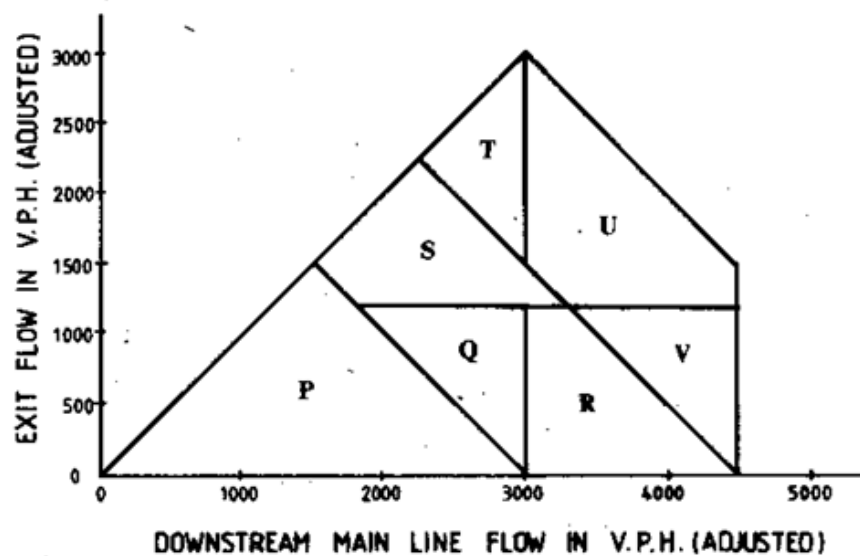
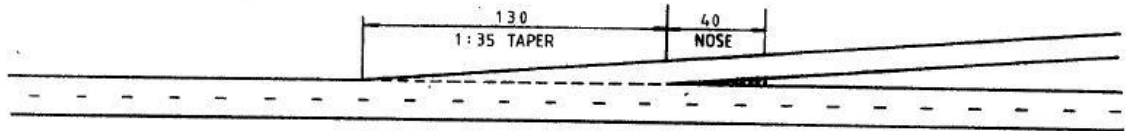
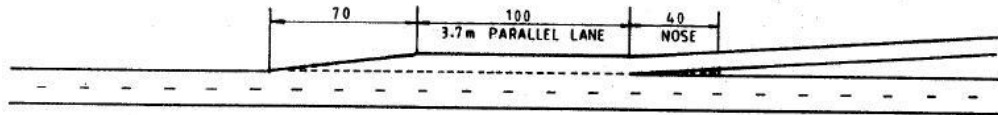

DIAGRAM 4.6.9.2 : DIVERGING LANES (DESIGN SPEED 80 km/h)
DIRECT DIVERGING LANE (TYPES 1 + 3)



PARALLEL DIVERGING LANE (TYPES 1 + 3)



TYPE 1 ONE LANE LINK FROM TWO LANE MAIN LINE

TYPE 3 ONE LANE LINK FROM THREE LANE MAIN LINE

NOTE: ALL DIMENSIONS IN METRES

DIAGRAM 4.6.9.3 : DIVERGING LANES (DESIGN SPEED 80 km/h)
DIRECT DIVERGING LANES (TYPES 2 + 5)

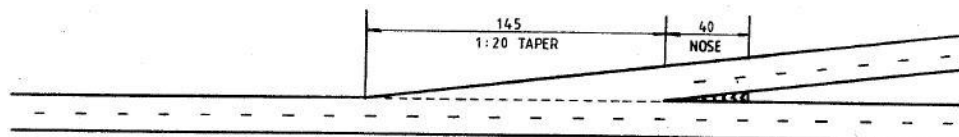

PARALLEL DIVERGING LANES (TYPES 2 + 5)

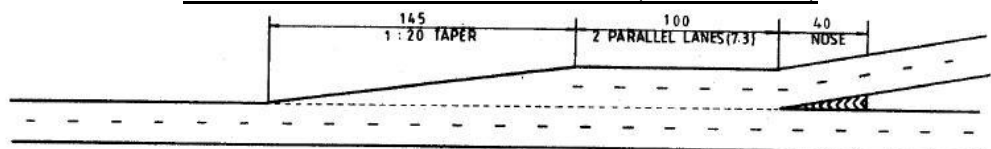

TYPE 2 TWO LANE LINK FROM TWO LANE MAIN LINE

TYPE 5 TWO LANE LINK FROM THREE LANE MAIN LINE

NOTE: ALL DIMENSIONS IN METRES

DIAGRAM 4.6.9.4 : DIVERGING LANES (DESIGN SPEED 80 km/h)
DIRECT DIVERGING LANES (TYPES 4 + 6)

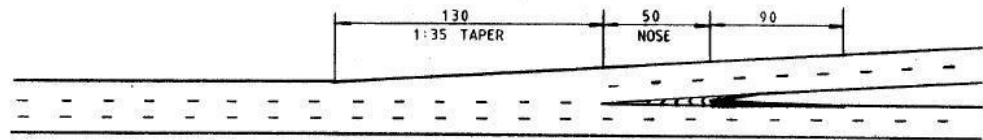

PARALLEL DIVERGING LANES (TYPES 4 + 6)

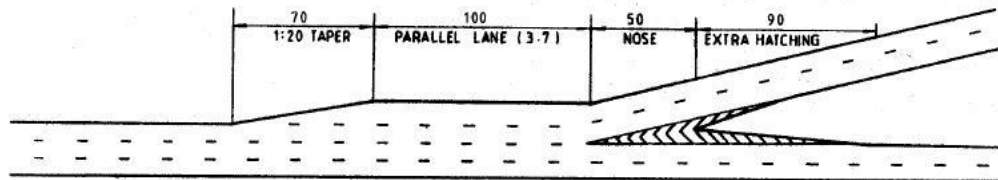

TYPE 4 TWO LANE LINK - MAIN LINE THREE LANES DECREASING TO TWO LANES

TYPE 6 TWO LANE LINK - MAIN LINE FOUR LANES DECREASING TO THREE LANES

NOTE: ALL DIMENSIONS IN METRES

DIAGRAM 4.6.9.5 : DIVERGING LANES (DESIGN SPEED 80 km/h)
DIVERGING LANE (TYPES 7 + 8)

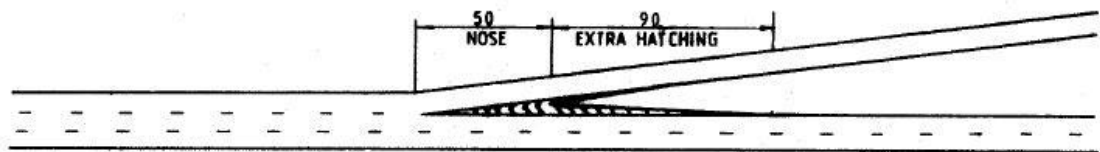

DIVERGING LANES (TYPE 9)

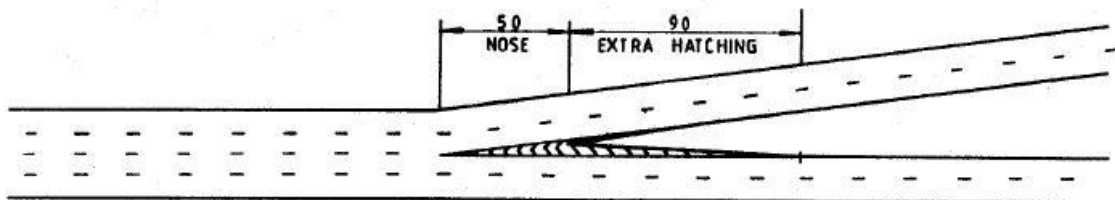

TYPE 7 SINGLE LANE LINK - MAIN LINE THREE DECREASING TO TWO

TYPE 8 SINGLE LANE LINK - MAIN LINE FOUR DECREASING TO THREE

TYPE 9 TWO LANE LINK - MAIN LINE FOUR DECREASING TO TWO

NOTE: ALL DIMENSIONS IN METRES

4.6.10 Weaving Sections

4.6.10.1 The following paragraphs cover the design of all true weaving sections, that is to say those areas where traffic streams, each moving in the same general direction, cross each other by successive merging and diverging manoeuvre. Such areas may occur on carriageways between adjacent junctions, between successive entry and exit slips and on links within free-flow interchanges. The advice does not cover what are at times wrongly referred to as weaving sections within roundabouts.

4.6.10.2 In essence the design procedure involves the assessment of the length and width of weaving section required to cater for the predicted design year flows. The minimum weaving section length is determined from consideration of the weaving flows and the design characteristics of the road. Based on the minimum and actual weaving section lengths the weaving section width is derived. Each step of the procedure is described in the following paragraphs and illustrated with examples in Appendix 3.

4.6.10.3 Predictions are made of the peak hour design year traffic volumes. These traffic volumes are required in the form of non weaving (Q_{nw}), major weaving (Q_{w1}) and minor weaving (Q_{w2}) components as illustrated below :

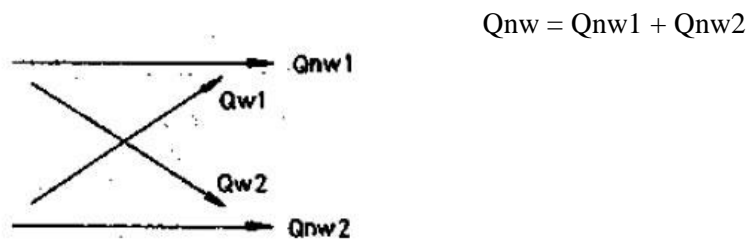

These traffic volumes are adjusted for non standard traffic composition and gradient using Table 4.6.8.1. The gradient should be measured over the approximate length of the weaving section plus a distance upstream of the weaving section up to 0.5 km in length.

4.6.10.4 The minimum weaving length based on the total weaving flow ($Q_{w1} + Q_{w2}$ adjusted) is given by reference to Diagram 4.6.10.1. Line A should be used for very high standard rural roads with high design speeds around 100 km/h and consequently low design flows around 1200 v.p.h. per lane. Line B should be adopted for the more normal standard of high capacity road in Hong Kong with a design speed around 80 km/h and a design flow of 1400 v.p.h. per lane. Line C represents the urban condition with low design speed around 50 km/h and consequently higher design flow of 1600 v.p.h. per lane

The minimum weaving section length derived as above should be compared with the minimum weaving section length indicated by the small graph, related to design speed alone, and the larger of the two values is the minimum acceptable length of weaving section (L_{min}).

- 4.6.10.5 The actual weaving length, particularly in connection with a weaving section between rather than within interchanges, will often be greater than the minimum weaving length. The width of weaving section is hence defined as a function of both the minimum and actual weaving lengths together with the predicted and design flows. The number of lanes required in the weaving section (N) is given by the equation

$$N = \frac{Q_{nw} + Q_{w1}}{D} + \left(2 \times \frac{L_{min}}{L_{act}} + 1\right) \frac{Q_{w2}}{D}$$

Where	Q_{nw}	= total non weaving flow (adjusted) v.p.h.
	Q_{w1}	= major weaving flow (adjusted) v.p.h.
	Q_{w2}	= minor weaving flow (adjusted) v.p.h.
	D	= design flow per lane in v.p.h. as described in para. 4.6.10.4
	L_{min}	= minimum weaving length (m)
	L_{act}	= actual weaving length (m)

- 4.6.10.6 The number of lanes within the weaving section as calculated above will invariably involve a fraction and a decision must be taken on whether to round up or down. In some cases it may be possible to vary the actual weaving length in order to bring N nearer to a whole number and hence simplify the decision. Where the available weaving length is fixed by outside constraints, as is normally the case, the decision to round up or down becomes more difficult. Obviously if the fractional part is small with relatively low weaving volumes and a low design flow, it is not unreasonable to round down. If the opposite is true, N would be rounded up. Between these two extremes it is necessary to exercise judgement taking account of such factors as cost and availability of lane for an extra lane.
- 4.6.10.7 It is also important to bear in mind that it is not sufficient merely to provide the proper number of lanes; the physical arrangement of the lanes within the weaving section must also be considered. Care must be taken that use of the lanes by weaving and non weaving traffic will be in proportion to their relative volumes so that parts of the roadway do not become underused while other parts become congested. The possibility of such an imbalance of flows occurring may well influence the decision on whether to round up or down. For example an outer lane added to a weaving section will generally aid only an outer non-weaving flow (particularly where 3 or more lanes are already proposed). This is likely to be of little use if most of the traffic is weaving and the relevant outer non-weaving flow is small.
- 4.6.10.8 Finally it is necessary to ensure that the number of lanes in the weaving section satisfies the requirements of the merging and diverging sections of the interchange(s) as discussed earlier.

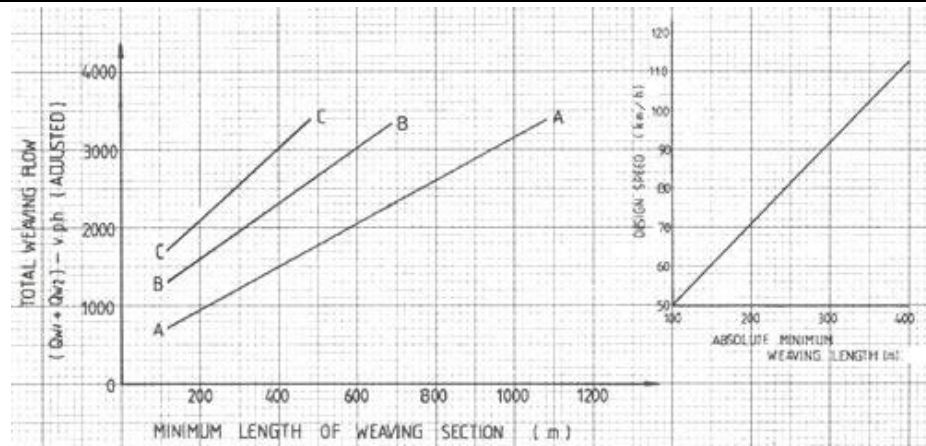
DIAGRAM 4.6.10.1 : L_{min} MINIMUM LENGTH OF WEAVING SECTION**4.6.11 Signing**

- 4.6.11.1 Of all junction types, the layout of grade separated interchanges is usually the least obvious to approaching motorists. It is imperative therefore, particularly where high speeds are involved, to ensure adequate signing. On trunk roads and primary distributor roads with no at grade access the signing should commence with the first A.D. sign, half a kilometre in advance of the commencement of the deceleration lane. Full details of signing are given in Volume 3 of this Manual.

Appendix 1

Calculation of Capacity at Priority Junctions

The predictive equations discussed in paras. 4.3.6 are :

$$Q_{B-A} = D[627 + 14W_{CR} - Y(0.364q_{A-C} + 0.144q_{A-B} + 0.229q_{C-A} + 0.52q_{C-B})] \dots\dots\dots (1)$$

$$Q_{B-C} = E[745 - Y(0.364q_{A-C} + 0.144q_{A-B})] \dots\dots\dots (2)$$

$$Q_{C-B} = F[745 - 0.364Y(q_{A-C} + q_{A-B})] \dots\dots\dots (3)$$

(where $Y = (1 - 0.0345W)$)

In each of these equations the geometric parameters represented by D, E and F are stream-specific :

$$D = [1 + 0.094(w_{B-A} - 3.65)][1 + 0.0009(V_{rB-A} - 120)][1 + 0.0006(V_{lB-A} - 150)]$$

$$E = [1 + 0.094(w_{B-C} - 3.65)][1 + 0.0009(V_{rB-C} - 120)]$$

$$F = [1 + 0.094(w_{C-B} - 3.65)][1 + 0.0009(V_{rC-B} - 120)]$$

The symbols represent the following :-

Q_{B-A}	= the capacity of movement B – A)See Drg. No. 4.3.A.1
Q_{A-B}	= the capacity of movement A – B and so on)Capacities and flow are in pcu/hour (1 HGV = 2 pcu)
W	= major road width)See Drg. No. 4.3.A.2
W_{CR}	= central reserve width (kerbed median only)	
W_{B-A}	= lane width available to vehicle waiting in stream B – A, and so on)See Drg. No. 4.3.A.3
V_{rB-A}	= visibility to the right for vehicles waiting in stream B – A)Visibilities distances for minor road flow is measured
V_{lB-A}	= visibility to the left for vehicles waiting in stream B – A, and so on)from a point 10m back from the give way line

All distances and widths are measured in metres and the ranges of parameters in the data base were as follows :-

$$w = 2.05 - 4.70$$

$$V_r = 17.0 - 250.0$$

$$V_l = 22.0 - 250.0$$

$$W_{CR} = 1.2 - 9.0 \text{ (kerbed central reserve only)}$$

$$W = 6.4 - 20.0$$

The maximum values of visibility and WCR used in calculation and computation should be 250m and 10m respectively, even if greater values are physically provided.

N.B.

- (i) The equations for Q_{B-A} and Q_{B-C} assume separate lanes for right and left turning minor road traffic and no simultaneous queuing for the two movements. If simultaneous queues are sometimes present Q_{B-A} is unaffected but the operational left turning capacity $Q_{B-C}(0)$ is :-

$$Q_{B-C}(0) = Q_{B-C} \left(1 - \frac{0.25}{Q_{B-A}} q_{B-A} \right) \quad \text{for } \frac{q_{B-A}}{Q_{B-A}} < 1$$

and $Q_{B-C}(0) = 0.75Q_{B-C} \quad \text{for } \frac{q_{B-A}}{Q_{B-A}} < 1$

If right and left turning traffic share the same lane the capacity of the combined stream is given as follows :-

$$Q_{B-AC} = \frac{Q_{B-C} \cdot Q_{B-A}}{(1-F)Q_{B-C} + FQ_{B-A}}$$

where Q_{B-A} and Q_{B-C} are determined using equations 1 and 2 with the same minor stream width w for both streams and F is the proportion of minor road traffic turning left.

- (ii) At some layouts the straight through major road stream C-A becomes blocked when there is a queue of right turning vehicles C-B. Substantial capacity limitations will arise only in those cases where the residual width for through traffic is less than 2.5m. In these cases Q_{C-A} is given by the equation :-

$$Q_{C-A} = 1800 \left(1 - \frac{q_{C-B}}{Q_{C-B}} \right) \text{pcu/h}$$

There follows an example in the use of the priority junction capacity equations.

Example of Use of Priority Junction Capacity Equation

- (1) It is required to examine the feasibility of a priority junction at the T-junction between two S2 roads.
- (2) The traffic information available from the traffic model indicates that the design year flows at the junction would be :

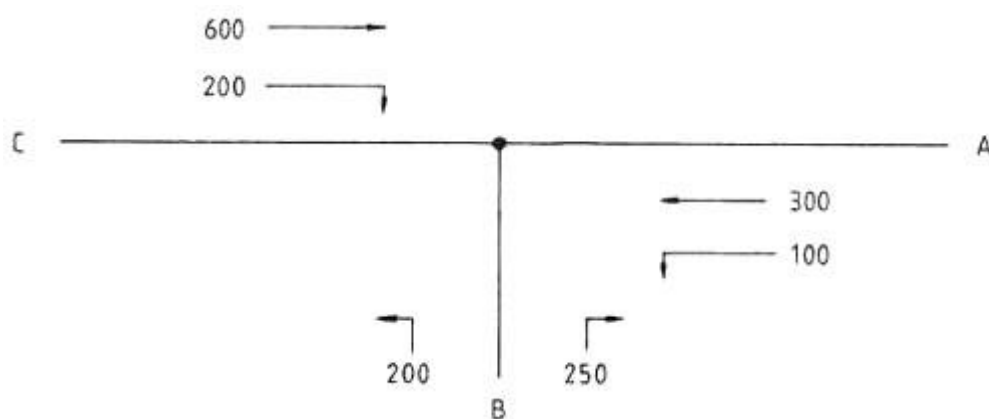

- (3) A layout is prepared based on a shadow island design and the initial layout has the following geometric parameters :

$$W = 7.3$$

$$W_{CR} = 0 \text{ (because no kerbed central median)}$$

$$w_{C-B} = 3.5$$

$$w_{b-c} = 4.0$$

$$w_{b-a} = 4.0$$

$$w_{b-a} = 250.0 \text{ major road}$$

$$V_r = 200.0 \text{ minor road}$$

$$V_l = 200.0 \text{ minor road}$$

- (4) Applying the stream specific formulae to calculate the factors D, E and F :

$$D = [1 + 0.094(4 - 3.65)][1 + 0.0009(200 - 120)][1 + 0.0006(V_{IB-A} - 150)] = 1.1405$$

$$E = [1 + 0.094(4 - 3.65)][1 + 0.0009(200 - 120)] = 1.1073$$

$$F = [1 + 0.094(3.5 - 3.65)][1 + 0.0009(250 - 120)] = 1.1013$$

Substituting these in the capacity formulae :

$$Q_{b-a} = 1.1405[627 + 14 \times 0 - 0.74815(0.364 \times 300 + 0.144 \times 100 + 0.229 \times 600 + 0.520 \times 200)] = 293$$

$$Q_{b-c} = 1.1073[745 - 0.74815(0.364 \times 300 + 0.144 \times 100)] = 615$$

and

$$Q_{c-b} = 1.1013[745 - 0.364 \times 0.74815(300 + 100)] = 700$$

comparing the capacities to the design flows yields DFC values of 85% for B-A, 33% for B-C and 29% for C-B.

The results indicated that the junction should operate satisfactorily with queuing on the B-A stream, i.e. the right turn out of the minor road. It would therefore be appropriate to examine the effects of queuing on the minor road and to critically examine the traffic predictions for that particular flow to ensure that the true future flow is unlikely to be higher than that initially predicted.

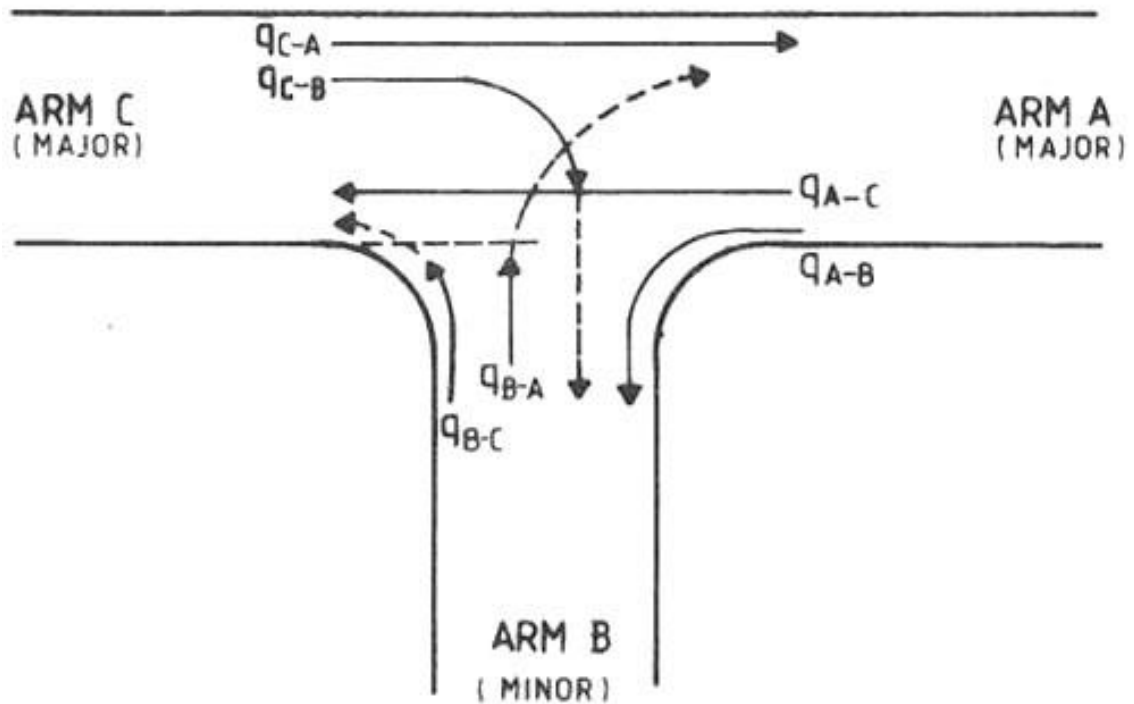
DIAGRAM 4.3.A.1: FLOWS AND NOTATION

The four parts of drawings show the main components of major road width. They are combined to give :

- (1) the 'nearside' width: W_n

$$W_n = \frac{1}{2}(W_2 + W_4)$$

- (2) the 'farside' width: W_f

$$W_f = \frac{1}{2}(W_1 + W_3)$$

- (3) the total carriageway width: W

$$W = (W_n + W_f)$$

- (4) (at dual carriageway sites with kerbed central reserve)

the width of central reserve: W_{CR}

$$W_{CR} = \frac{1}{2}(W_5 + W_6)$$

DIAGRAM 4.3.A.2: MAJOR ROAD WIDTH W AND ITS COMPONENTS

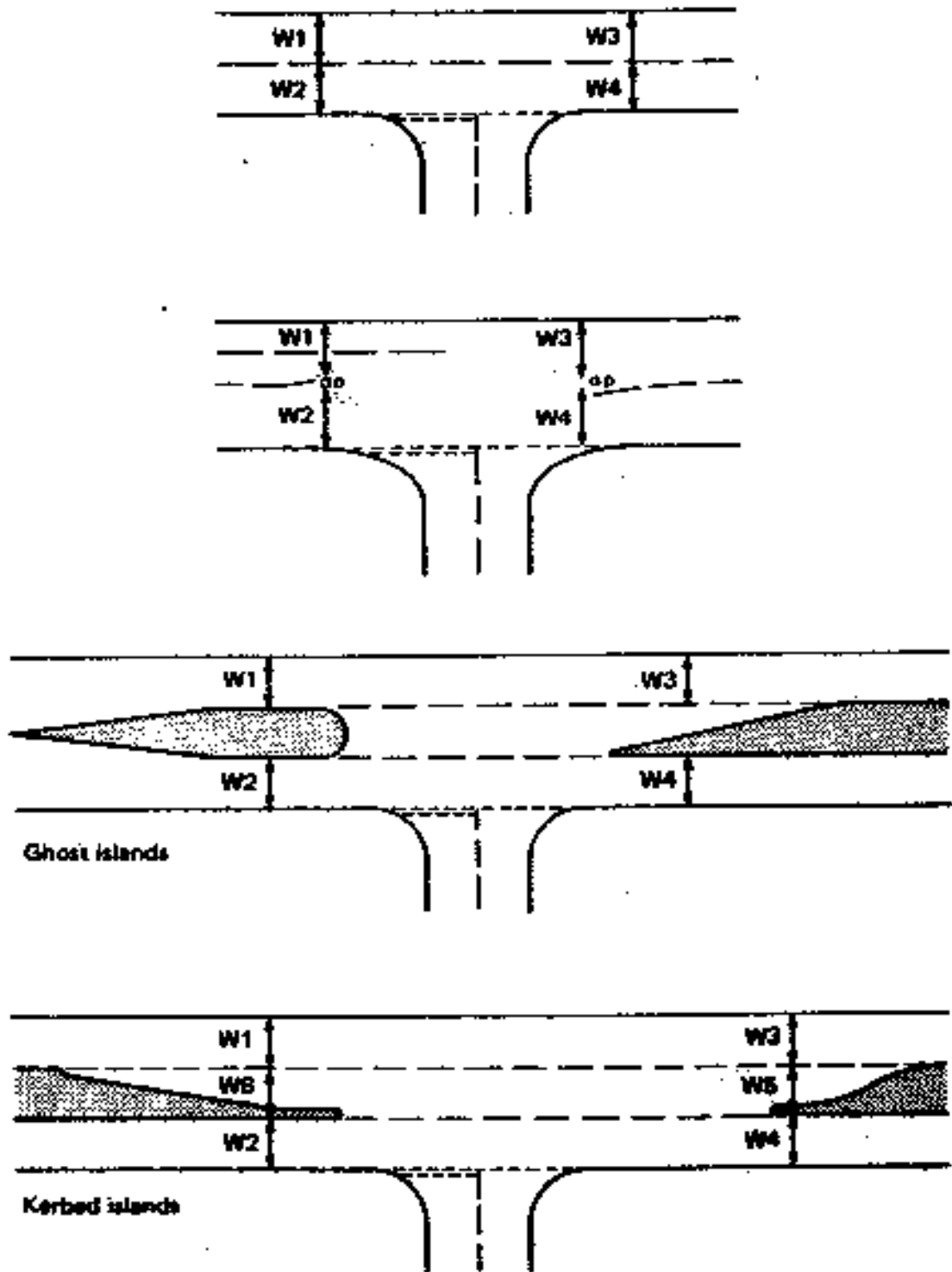

Lane width for non-priority streams, w (m)

Where there are clear lane markings the width is measured directly. The average of measurements taken at 5m intervals over a distance of 20m upstream from the give-way point is used. Any measurement exceeding 5m is reduced to 5m before the average is taken. Where lane markings are unclear (or absent), Diagram (a), (b), and (c) are used, and the lane width calculated according to :

DIAGRAM 4.3.A.3 : LANE WIDTHS FOR NON PRIORITY STREAMS

$$W = (a + b + c + d + e) / 5 \text{ metres}$$

Diagram (a) Lane width measurements for the right-turning minor road stream

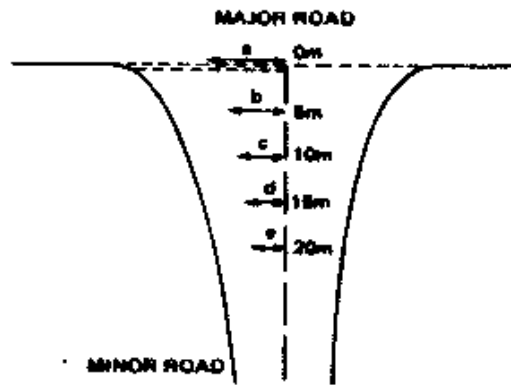

a, b, c, d, e are equal to $\frac{1}{2}$ (approach width to nearside of median line)
Each $\leq 5\text{m}$

Diagram (b) Lane width measurements for the left-turning minor road stream

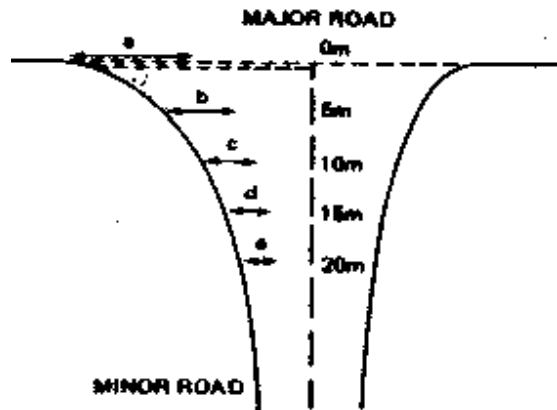

a, b, c, d, e are equal to $\frac{1}{2}$ (approach width to nearside of median line)
Each $\leq 5\text{m}$

Diagram (c) Lane width measurements for the right-turning major road stream

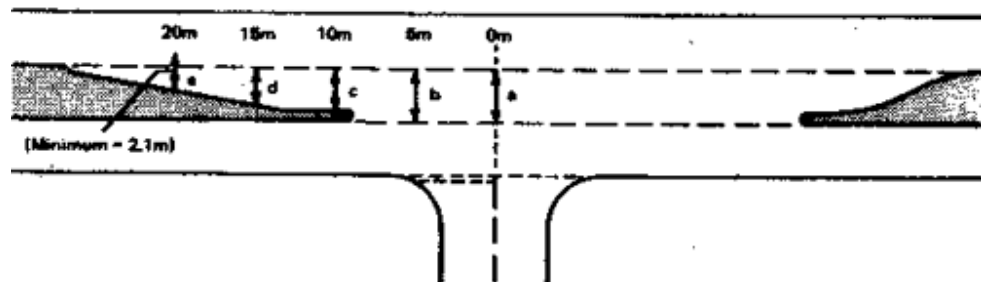

a, b, c, d, e are equal to the lane width where there is explicit provision for right-turners (each $\leq 5\text{m}$), and equal 2.1m otherwise

Appendix 2

Calculation of Capacity at Priority Roundabouts

The predictive equations for entry capacity on individual arms of roundabouts is :-

$$Q_E = K(F - f_c q_c)$$

where

$$Q_E = \text{entry capacity in pcu/hour (1 HGV} = 2\text{cpu)}$$

$$q_c = \text{Circulating flow across the entry in pcu/hour}$$

$$K = 1 - 0.00347(\varphi - 30) - 0.978[(1/r) - 0.05]$$

$$F = 303x_2$$

$$f_c = 0.210t_D(1 + 0.2x_2)$$

$$t_D = 1 + 0.5/(1 + M)$$

$$M = \exp[(D - 60)/10]$$

$$x_2 = v + (e - v)/(1 + 2S)$$

$$S = 1.6(e - v)/L$$

The geometric parameters are defined below together with their recommended limits :-

e	= entry width	4.0 - 15.0m
v	= approach half width	2.0 - 7.3m
L	= effective length of flare	1.0 - 100.0m
S	= $1.6(e - v)/L$ = sharpness of flare	0.0 - 3.0
r	= entry radius	6.0 - 100.0m
φ	= entry angle	10 - 60 degrees
D	= inscribed circle diameter	15 - 100m

The circulatory width does not appear in the equation but should be constant at 1.0 to 1.2 times the greatest entry width subject to a maximum of 15m.

The predictive equation applies to all roundabouts except those at grade separated interchanges where the term "F" should be replaced by "1.11 F" and the " f_c " term becomes "1.4 f_c ".

Further explanation of the geometric parameters is given below with reference to the associated figures.

e = the entry width, measured from the point A along the normal to the nearside curve

v = the approach half width, measured at a point in the approach upstream from the entry flare

r = the entry radius, measured as the minimum radius of curvature of the nearside kerblines at entry. It is not important that this minimum arc may extend into the following exit provided that half or more of the arc length is within the entry region

- $L =$ the effective flare length, measured as shown in Fig. 2 The line GF'D is the projection of the nearside kerb from the approach towards the give wayline, parallel to the median HA and at a distance of v from it. BA is the line along which e is measured and thus D is at a distance of $(e - v)$ from B. The line CF' is parallel to BG (the nearside kerb) and at a distance of $\frac{e-v}{2}$ from it. Usually the line CF' is therefore curved and its length is measured along the curve to obtain L
- $D =$ the inscribed circle diameter, is the largest circle that can be inscribed within the junction outline as shown in Fig. 1. In cases where the outline is a symmetric, the local value in the region of the entry is taken. The extreme case arises for a double roundabout at a scissors crossroads and Fig. 3 illustrates the determination of D in such cases
- $\varphi =$ the entry angle and serves as a proxy for the conflict angle between entering and circulating streams. Three constructions are used for φ . The first two shown in Figs. 4 and 5 apply to roundabouts having a distance of more than about 30m between the offside of an entry and the next exit. In these cases is not affected by the angle of the adjacent exit. Fig. 6 shows the construction where entry and next exit are closed together and is more related to exit angle than circulating angle

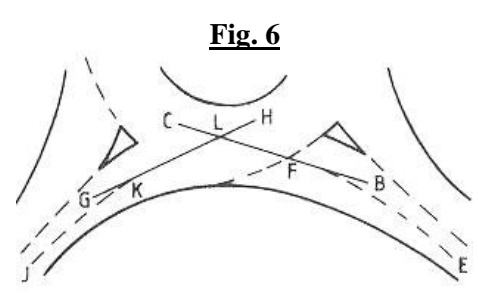
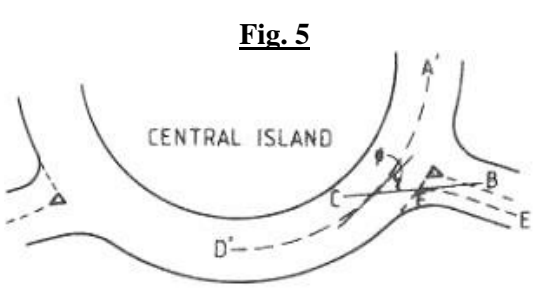
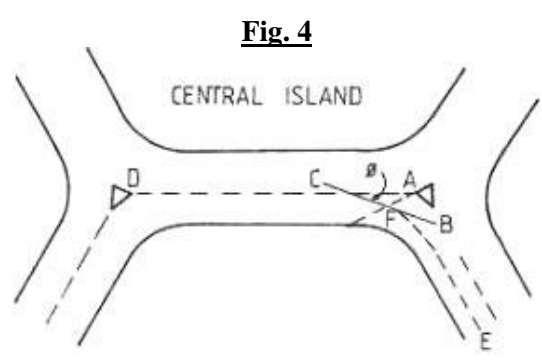
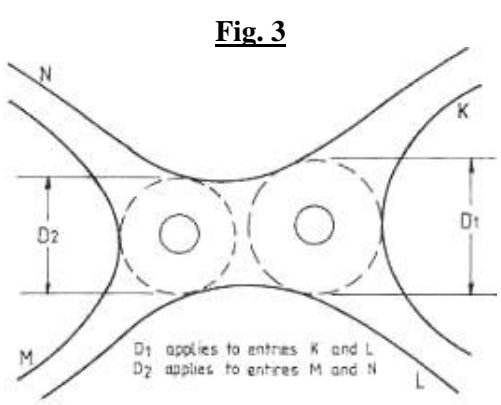
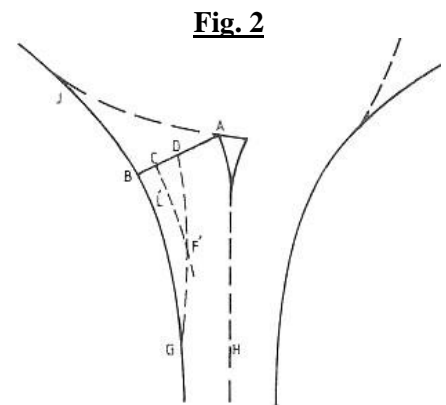
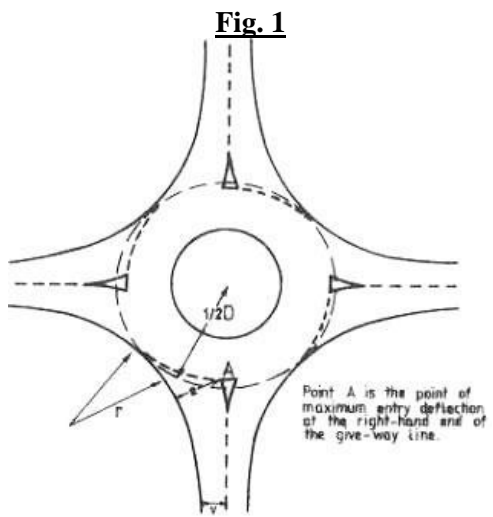

Fig. 4 shows a straight circulatory carriageway. AD is parallel to the straight circulatory carriageway where A is as in Fig. 1 and D is the point nearest to A on the median island or marking of the following entry. Line EF is mid way between the nearside kerbline and the median line and nearside edge of any median island. Line BC is a tangent to EF at the point where it intersects the give way line. ϕ is measured as the acute angle between lines BC and AD.

Fig. 5 shows the equivalent construction for roundabouts with curved weaving sections. A'D' is a line in the centre and parallel to the weaving section. BC is constructed as with Fig. 4 and ϕ is measured as the acute angle between BC and the tangent to A'D' at the point of intersection.

Fig. 6 shows the construction for short weaving sections. BC is constructed as in Figs. 4 and 5. JK is the line in the following exit mid way between the nearside kerb and the median and offside edge of any median island. GH is the tangent to JK at the point where this line intersects the outer edge of the circulatory carriageway. BC and GH intersect at L. ϕ is then defined as $\phi = 90 - (\text{angle GLB})/2$. GLB is measured on the side facing away from the central island. If GLB is greater than or equal to 180° $\phi = 0$

Entry path radius: is not one of the geometric parameters included in the capacity equation, but has a major influence on safety. The following procedure may be adopted to measure the entry path radius :-

It is assumed that :-

- (i) The entering vehicle is 2m wide and will be taking the straight ahead movement at a 4 arm roundabout or across the head of the Tee at a 3 arm roundabout;
- (ii) There is no other traffic on the approach and on the circulatory carriageway;
- (iii) The driver will negotiate the site constraints with minimum deflections and road markings will be ignored;
- (iv) The vehicle is first considered at a point not less than 50m from the "Give Way" line;
- (v) The vehicle proceeds towards the "Give Way" line on a path whose centre line initially 1m away from the nearside channel or kerb of the approach arm;
- (vi) Then either :-
 - (a) It proceeds towards the central island of the roundabout passing through a point not less than 1m from the nearside channel or kerb; or
 - (b) Where a subsidiary traffic island exits, it is assumed to pass whichever side of the island involves the least deflection;
- (vii) The vehicle is then assumed to continue on a smooth path with its centre line never passing closer than 1m from the centre island.

Based on the foregoing, which is diagrammatically represented in Drg. No. 4.5.A.1, the centre line of the most realistic path that a vehicle would take in its complete passage through the junction is drawn on a 1/500 scale using a flexicurve or similar. More than one line should be drawn and the most critical path considered. The entry path curvature is taken to be the tightest radius over a 20 - 25 m length in the vicinity of the "Give Way" line (i.e. between X and Y on Drg. No. 4.5.A.1). The radius should be measured using a suitable template.

Example of Use of Roundabout Capacity Equation

- (1) It is required to assess the viability of a roundabout layout at the junction between a Dual 2 and a Single 2 road.
- (2) The traffic information available indicates the following design year flows :-

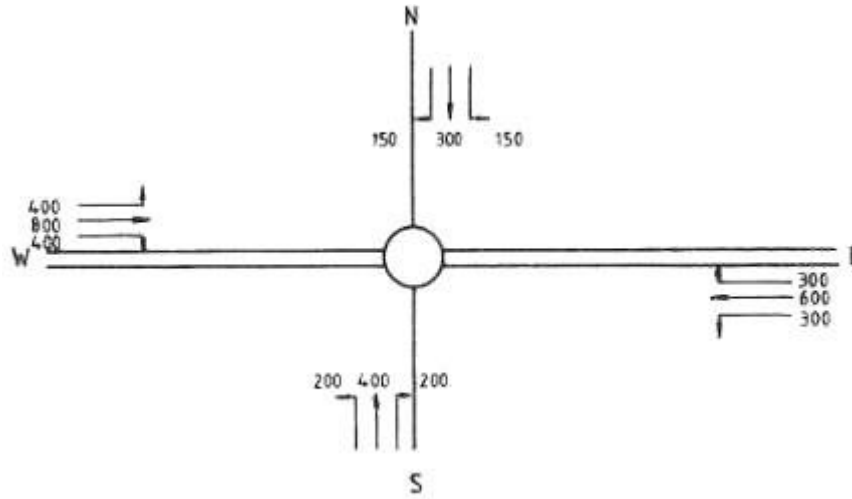

The flows on the roundabout and its entries therefore would be :-

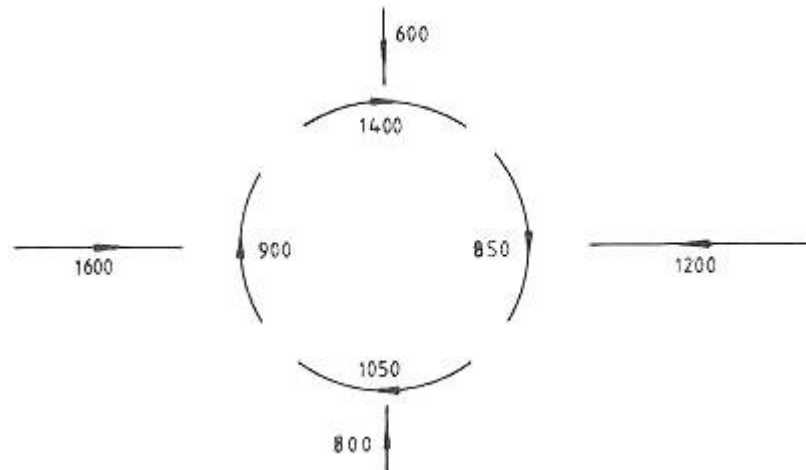

- (3) A roundabout layout is prepared with the following design characteristics :-

ARM	v (m)	e (m)	L (m)	r (m)	D (m)	φ (degrees)	S
SOUTH	3.65	7.30	25.0	20.0	63.0	30.0	0.23
WEST	7.30	10.50	25.0	20.0	63.0	30.0	0.20
NORTH	3.65	7.30	25.0	20.0	63.0	63.0	0.23
EAST	7.30	10.50	25.0	20.0	63.0	30.0	0.20

- (4) Using these design figures the parameters in the equation :

$Q_E = K(F - f_c q_c)$ can be calculated

	South	West	North	East
$q_c =$ Circulating flow across the entry	1050	900	1400	850
$K = 1 - 0.00347(\phi - 30) - 0.978(1/r - 0.05)$	1.000	1.000	1.000	1.000
$x_2 = v + [(e - v)/(1 + 2S)]$	6.14	9.57	6.14	9.57
$M = \exp[(D - 60)/10]$	1.35	1.35	1.35	1.35
$F = 303x_2$	1859.73	2899.75	1859.73	2899.75
$t_D = 1 + (0.5/1 + M)$	1.213	1.213	1.213	1.213
$f_c = 0.210t_D(1 + 0.2x_2)$	0.567	0.742	0.567	0.742
$Q_E = K(F - f_c q_c)$	1264	2232	1065	2269

- (5) Comparing the entry capacities with the entry flows gives DFC ratios for the south, west, north and east arms of 63%, 72%, 56% and 53% respectively. The proposed roundabout would hence cater for the design flows adequately with no queuing. If benefits were to be obtained in land take etc. a smaller roundabout could be tested.

DIAGRAM 4.5.A.1 : DETERMINATION OF ENTRY PATH CURVATURE

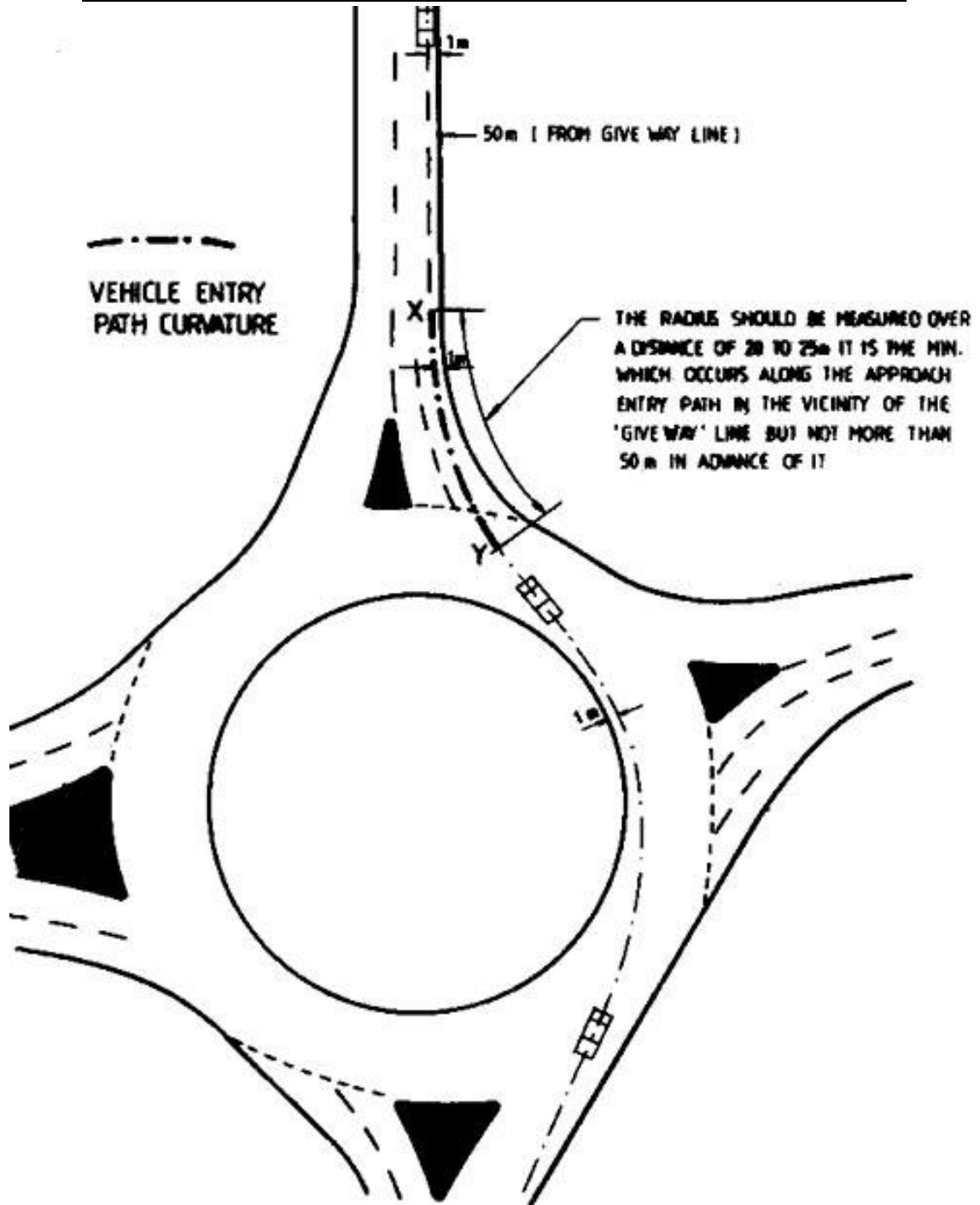

Appendix 3

Examples of Weaving Section Calculations

Example 1

A new road is to be constructed within an existing urban area with a design speed of 50 km/h and a design flow of 1600 v.p.h. per lane. Over one particular section the weaving section length between an entry and the adjacent exit is limited by connections to the existing road network to 200m.

The predicted design year flows in vehicles per hour are :-

$$\begin{aligned} Q_{nw1} &= \text{major non weaving flow} = 1500 \text{ v.p.h} \\ Q_{nw2} &= \text{minor non weaving flow} = 600 \text{ v.p.h} \\ Q_{w1} &= \text{major non weaving flow} = 1000 \text{ v.p.h} \\ Q_{w2} &= \text{minor non weaving flow} = 800 \text{ v.p.h} \end{aligned}$$

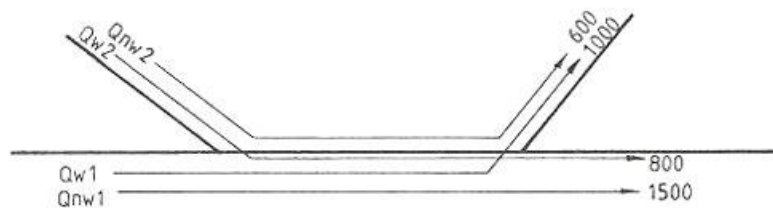

The average gradient through the section and 0.5 km upstream of the merge is 1% uphill and the predicted heavy vehicle content is 25%. From Table 4.6.8.1 therefore the predicted flow should be adjusted by +8% resulting in the following adjusted flows :-

$$Q_{nw1} = 1620, \quad Q_{nw2} = 648, \quad Q_{w1} = 1080, \quad Q_{w2} = 864$$

The total weaving flow is thus 1944.

From paragraph 4.6.10.4 using line C - C (for urban conditions)

$L_{min} = 170\text{m}$ (N.B. this is greater than the absolute minimum figure indicated in the small graph inset of Dia. 4.6.10.1)

Number of lanes required within weaving section :-

$$N = \frac{Q_{nw1} + Q_{nw2} + Q_{w1}}{D} + \left(2 \times \frac{L_{min}}{L_{act}} + 1\right) \frac{Q_{w2}}{D}$$

Where D = design flow per lane

And L_{act} = actual weaving length

$$N = \frac{1620 + 648 + 1080}{1600} + \left(2 \times \frac{170}{200} + 1\right) \frac{864}{1600}$$

$$L = 3.55 \text{ Lanes}$$

The decision whether to round up or down the number of lanes will depend upon site specific factors. For example with the flows involved the main line may be a dual 2 or a dual 3 carriageway. In the case of a single lane slip joining a dual 3 it would be sensible to maintain 4 lanes throughout the whole weaving section. Alternatively if a single lane slip were joining a dual 2 as shown below the decision whether to add a fourth lane would depend on cost and availability of land etc.

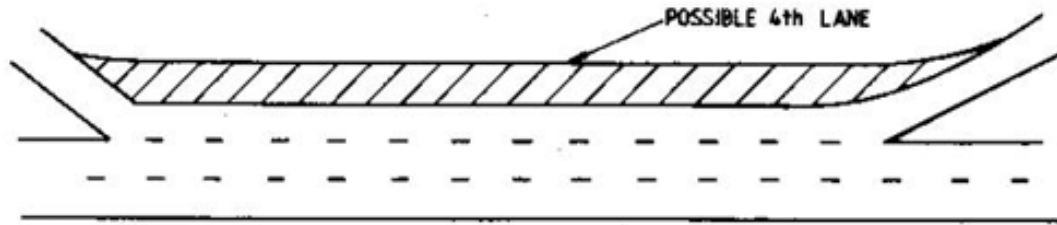

In other circumstances where the actual weaving length was not fixed, opportunity could be taken to increase the spacing between the entry and exit points. For example in the case in question, if the *Lact* were increased to 400m and all other factors were identical *N* would be almost exactly 3 lanes and the decision regarding weaving section width would be straight forward.

It should be noted that the minimum weaving section lengths in the above example based on urban conditions and a low design speed are not comparable with the standards recommended for the sum of the merging and diverging section lengths in sections 4.6.8 and 4.6.9 which are based on a design speed of 80 km/h. Example 2 is more typical of the higher standard provision.

Example 2

A dual 3 lane by-pass with a 80 km/h design speed and 1400 v.p.h. per lane design flow is to be constructed as part of a New Town highway network. On one particular section of the by-pass the weaving length available is approximately 1.5 km though this is somewhat flexible as all the adjoining road network is also new.

The predicted design year flows in vehicles per hour are :-

Q_{nw1}	= major non weaving flow	= 2200 v.p.h
Q_{nw2}	= minor non weaving flow	= 600 v.p.h
Q_{w1}	= major weaving flow	= 900 v.p.h
Q_{w2}	= minor weaving flow	= 700 v.p.h

The average gradient through the section and 0.5 km upstream of the merge is 2% downhill and the predicted heavy vehicle content is 15%. From Table 4.6.8.1 therefore no adjustment is required to the predicted flows.

The total weaving flow is thus 1600 v.p.h.

From Diagram 4.6.10.1 using line B-B (for 80 km design speed and 1400 v.p.h. per lane design flow) the minimum weaving section length $L_{min} = 240m$ (N.B. this is taken from the small graph inset which produces a larger figure than the main graph).

Number of lanes required within weaving section :-

$$N = \frac{Q_{nw1} + Q_{nw2} + Q_{w1}}{D} + \left(2 \times \frac{L_{min}}{L_{act}} + 1 \right) \frac{Q_{w2}}{D}$$

$$N = \frac{2200 + 600 + 900}{1500} + \left(2 \times \frac{240}{1500} + 1 \right) \frac{700}{1400}$$

$$L = 3.3 \text{ Lanes}$$

As the fractional part is small and the weaving flows are not relatively high it would be advisable in this situation to maintain the dual three character of the road and provide a three lanes wide weaving section. The full merging and diverging lane requirements as stated in sections 4.6.8 and 4.6.9 would in any case be provided.

Consider also the situation which is the same in all respect except that the actual weaving section length is only 600m.

In these circumstances the number of lanes required in the weaving section would be 3.54. When one considers the lengths of merging and diverging lanes required there would be less than 200m between the end of one and the beginning of the other. In this situation it would generally be more sensible to run the additional fourth lane throughout the whole section.

TPDM Volume 2 Chapter 5 – Other Facilities

5.1 References

1. Chapter 8, *Hong Kong Planning Standards and Guidelines*
2. U.K. Department of Transport, Departmental Advice Note TA/36/83, *Signing and Siting of Road Humps: Two-way, 2-lane roads*
3. *U.K. Highways (Road Humps) Regulations* 1983
4. U.K. Department of Transport, *Circular Roads 5/83, Road Humps*
5. U.K. Department of Transport, *Circular Roads 17/78, Transverse Yellow Bar Markings at Roundabouts*
6. U.K. Department of Transport, Departmental Standard TD 6/79, *Transverse Yellow Bar Markings at Roundabouts*
7. T.R.R.L. Laboratory Report 800, *The use of rumble areas to alert drivers*
8. *Code of Practice for the Lighting, Signing and Guarding of Road Works*
9. Volume 3, *Transport Planning and Design Manual - Traffic Signs and Road Markings*
10. Civil Engineering Services Department, *Civil Engineering Manual, Volume II, Project Administration*

5.2 Introduction

5.2.1 General

5.2.1.1 This Chapter is intended to provide information on facilities which may influence the design of any road, or may be used to effect how any road is used.

5.2.1.2 It is important that consideration of the facilities mentioned in this Chapter is given at an early stage in the design procedure. This is to ensure that the provision of the facility will not detrimentally affect the design, e.g. that the location of a bus stop or filling station are considered during the design stage so that if they are required they can be sited at their optimum locations where visibility is maximised and interference with other road users is minimised rather than having to fit them in when the design has been completed. Additionally, it should be ensured that the facility will not be required, at a later date e.g. curve radii and visibility at hazards are sufficient that rumble strips or similar will not need to be provided at some future time.

5.3 Petrol Filling Stations in relation to Highway Design

5.3.1 Location of Petrol Filling Stations

- 5.3.1.1 Consideration must be given to what existing facilities are already available in the area when applications for new petrol filling stations or service areas, consisting of more than one petrol filling station and other auxiliary services, are made. Except as otherwise specified, petrol filling station in this chapter refers to conventional petrol filling station, petrol cum liquefied petroleum gas filling station and liquefied petroleum gas filling station and electric vehicle (EV) charging station .
- 5.3.1.2 Petrol filling stations must be located such that interference with traffic flow on the frontage road and any adjoining roads is minimised, and no additional traffic hazards are created.
- 5.3.1.3 Petrol filling stations should be located such that the journey distance for vehicles seeking petrol / charging is minimised, but at the same time avoiding any undesirable increase in traffic flow in adjacent or surrounding roads.
- 5.3.1.4 Turning movements into or out of the petrol filling station from/to the opposite traffic direction to the traffic immediately adjacent to it should be prevented. On Local Distributor Roads or below for example such movements can generally be tolerated.
- 5.3.1.5 Generally petrol filling stations should not be located adjacent to Trunk Roads and Primary Distributor Roads. However on Expressway, petrol filling stations should preferably form part of service areas.
- 5.3.1.6 It is desirable where two or more petrol filling stations are adjacent to each other that access to and from the main road is obtained via a common service road.
- 5.3.1.7 Sight distances in accordance with the minimum desirable standards on section 3.3.5 of Chapter 3 should be provided on the approach to the service area or petrol fitting station, and for vehicles leaving the service area or petrol filling station in accordance with section 4.3.8 of Chapter 4.
- 5.3.1.8 Service areas or petrol filling stations should preferably be sited opposite each other on dual carriageway roads. If they are single carriageway roads then they should be staggered within visible distance of each other, but not less than 100m apart, with the nearside filling station being the nearest to the approaching traffic on that side.
- 5.3.1.9 Where it is agreed that a filling station should be provided on a Trunk Road, including Expressways, or a Primary Distributor Road, or a Rural Road, the following must be taken account of :
- (i) Filling stations should not be located on any slip road of a grade separated junction.
 - (ii) On Expressways the petrol filling station, or service area, should be at least 2km from any intersection.
 - (iii) Merging and diverging lanes commensurate to the design standard of that road must be provided at access and egress points to and from the service area or petrol filling station.
 - (iv) The spacing between petrol filling stations or service areas should be at least :
 - (a) 10 km on Expressways, and
 - (b) 5 km on Trunk Roads and Primary Distributor Roads.
 - (v) The service area or petrol filling station must not be located within 100m of a bend, vertical curve or road junction.

- 5.3.1.10 On roads other than Trunk Roads, Expressways, Primary Distributor Roads or Rural Roads, the location of petrol filling stations or service areas should be in accordance with the following:
- (i) Where petrol filling stations on the same side of the road cannot be provided with a common service road they should preferably be situated at least 300m apart
 - (ii) Petrol filling stations should not be located within 50m of a bend, vertical curve or junction.
 - (iii) The carriageway width of the road on which the filling station fronts should not be less than 7.3m.

5.3.2 Layout of Petrol Filling Stations

- 5.3.2.1 For petrol filling stations or service areas located adjacent to Trunk Roads, particularly Expressways, Primary Distributor Roads and Rural Roads, as mentioned in section 5.3.1, the petrol filling station or the service areas will be served by a specially provided service road with appropriate merging and diverging lanes. Any access by pedestrians on to the main road must be prevented by suitable fences if necessary. Waiting spaces must be provided in accordance with section 5.3.2.2 so that queuing traffic must not be extended on to the major road and preferably not even on to the service road. A pedestrian footbridge may need to be provided to link the service areas on either side of the main road if a particular facility can only be provided on one side. Also on Expressways the service area may be sited in conjunction with a vehicle recovery centre or other facility associated with these types of road.
- 5.3.2.2 For all petrol filling stations a minimum of four waiting spaces should be provided within the site in addition to one space for and adjacent to each metered filling point. However for a combined petrol filling and service station an additional four spaces should be provided for each service bay. A service station being where activities such as general lubrication or tyre changing or car washing, can be carried out. An additional space should be provided between each air-pumping point. Waiting spaces must be easily accessible and located between the entrance and the pumps. For EV charging station, subject to the traffic review, adequate vehicle waiting spaces should be provided within EV charging stations.
- 5.3.2.3 Only one entry point and one exit point is to be provided under normal circumstances and petrol filling station shall be designed for one way operation to avoid reversion of vehicles and to prevent vehicles from taking short-cuts by entering via the egress point and leaving via the ingress point.
- 5.3.2.4 However where the petrol filling station is bordered by two or more roads additional entrances or exits may be provided if internal circulation would neither disrupt traffic circulation on the roads bordering the site nor adversely affect vehicle evacuation in emergency.
- 5.3.2.5 Any servicing must be carried out entirely within the petrol filling station area.
- 5.3.2.6 Where an existing footway fronting the site is less than 2.75m in width the site should be set back such that a footway of 2.75m minimum width can be provided. The length of the footway between an entry and exit located on the same road and measured at the back of the footway must not be less than 3m but should preferably be 10m. The site must comply with any building or widening lines and levels in the normal way.

- 5.3.2.7 A physical barrier must be constructed along the back of the footway to prevent vehicles from crossing the footway other than at the points of entrance or exit.
- 5.3.2.8 The minimum width at the back of the footway for the run-in and run-out should be 6.75m and 5m respectively. Widening of the run-in and run-out towards the kerblines of the adjacent carriageway to facilitate entry and exit is permitted but the widths at the kerblines should not normally exceed 10m and 8m respectively. Where wider entrances or exits are required the safety of pedestrians should not be adversely affected. Details regarding the layout of run-ins for filling stations are illustrated in Diagram 3.6.3.3 of Chapter 3.
- 5.3.2.9 Buildings or other structures associated with the petrol filling station should not be erected such that they interfere with any sight lines required.
- 5.3.2.10 Where road lighting does not exist adjacent to the petrol filling station lighting must be provided to adequately illuminate the entrance and exit, but should not be of such type which will dazzle motorists on adjacent roads.
- 5.3.2.11 Appropriate "IN", "OUT", "NO ENTRY" and "NO EXIT" signs must be erected to indicate the points of entry and exit to and from the petrol filling station. For details, refer to paragraph 2.3.2.105 of Chapter 2, Volume 3.
- 5.3.2.12 For details of siting, layout design, environmental, fire safety and visual consideration, refer to Chapter 12 Section 3 of *Hong Kong Planning Standards and Guidelines*.

5.4 Additional Speed Control Facilities

5.4.1 Definition

- 5.4.1.1 Additional speed control facilities may be regarded as devices used in addition to speed limit and warning signs where it is regarded that approach speeds to a particular hazard are excessive, though not necessarily above the speed limit in force, and warning signs alone are not considered sufficient to bring to the attention of drivers the need to reduce their speed.
- 5.4.1.2 Additional speed control facilities may be in the form of a road marking or an actual physical change to the road surface, or both.

5.4.2 Use

- 5.4.2.1 Additional speed control facilities will not generally be appropriate on Trunk Roads, including Expressways, or Primary Distributor Roads, as normally the geometric design of the road should be of a standard that the vehicle speeds do not need to be controlled by physical or other means over and above the general traffic aids and design features normally provided. However in exceptional circumstances their use may be justified but each case will need to be considered on its own merit and care will be needed as to the type of facility installed.
- 5.4.2.2 On other roads the use of additional speed control facilities over and above the use of speed limits maybe appropriate if it is considered that approach speeds to a particular hazard are excessive, and as such a potential accident risk exists and warning signs or similar are not sufficient on their own to reduce the speed of approaching vehicles, or provide adequate warning.
- 5.4.2.3 Additional speed control facilities should only be used in unusual situations where conventional warning devices would not achieve the desired results.
- 5.4.2.4 It is very important that any additional speed control device proposed to be used is appropriate for the type of road under consideration.
- 5.4.2.5 Certain additional speed control facilities mentioned will generate additional noise or cause vibrations in vehicles, and it will be necessary to ensure that these will not cause annoyance or any danger to arise.

5.4.3 Road Humps

- 5.4.3.1 A road hump is a raised device having a part circular shape of height not more than 75mm, installed across the full width of the carriageway at right angles to the direction of flow and when driven across at speeds generally in excess of 15-20 km/h causes discomfort to occupants of the vehicle. The objective being to limit speeds to less than 20 km/h.
- 5.4.3.2 If road humps are installed on public roads careful attention must be given to their location, and that they are properly signed in order to ensure that Government cannot be held responsible should an accident or damage to a vehicle occur.
- 5.4.3.3 In respect of any private roads, if road humps are required their design should follow the advice in this section. However, this advice should not in any way be taken as approval by the Transport Department for the provision of road humps on roads, and any road humps so installed remain in all aspects the responsibility of the Department or organisation installing them.
- 5.4.3.4 The cross section and dimensions of a road hump should conform to the dimensions given in Diagram 5.4.3.1. The hump should be installed across the full width of the road with 450mm wide flat channel allowed on each kerbside for drainage.

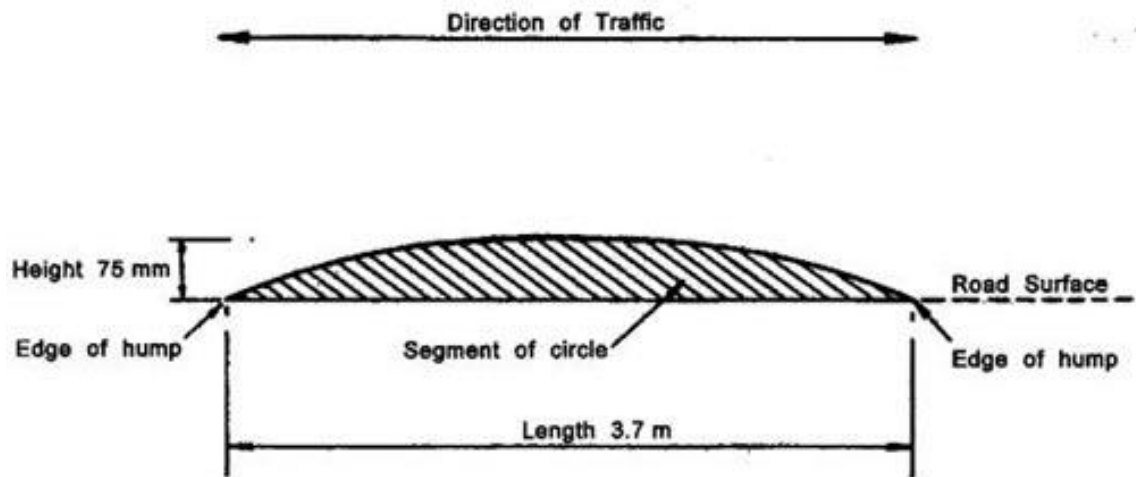
DIAGRAM 5.4.3.1 : CROSS SECTION AND HUMP DIMENSIONS

5.4.3.5 Road humps may be appropriate for two way 2-lane roads of width not greater than 10m and subject to a speed limit of 50 km/h. However on two way 3 or 4 lane roads and one way streets the use of road humps is not advisable because of the possible dangers of vehicles overtaking one another on or near the humps. On any road subject to a speed limit greater than 50 km/h road humps should never be used.

5.4.3.6 A road hump installation may comprise either a single hump or a series of humps up to 20 in number. For locations where a series of road humps are used the following is applicable.

- (i) Spacing between consecutive humps should be not less than 50m nor more than 150m.
- (ii) On roads which have gradients of more than 10% the maximum spacing should be reduced to 70m.
- (iii) A series of road humps should not extend for more than 1 km.

5.4.3.7

With regard to the siting of road hump installations, they should generally not be located, other than in special circumstances :

- (i) Within 8m of a road junction.
- (ii) Within 18m of the tangent point of a bend with an inner kerb radius of less than 50 metres and which requires a vehicle to change direction by more than 45 degrees.
- (iii) On the crossing itself, or within 30m of the crossing or within the limits of the zebra controlled area whichever is the greater.
- (iv) Within 70m either side of a signal controlled crossing.
- (v) Within 50m of a cautionary crossing place.
- (vi) On or within 20m of a light rail road crossing or similar, the 20m being measured from the running rail of the track nearest the hump.
- (vii) Within 25m of the nearest part of a structure over a road of which any part is 6.5m or less above the surface of the carriageway.
- (viii) Within 20m of any fire hydrant positioned along the footway of the road.
- (ix) Where street lighting which operates throughout the hours of darkness is not available, and preferably a lighting column should be within 5m of any hump.
- (x) Opposite any run-in, or any position where they might interfere with access to the run-in.
- (xi) Over any manhole cover, or where they might interfere with access to public utility apparatus.
- (xii) On or within 25m of any road carrying structure, such as a bridge, subway or culvert, in order to avoid the risk of structural damage occurring because of the increase in impact loading and vibration.
- (xiii) In or within 25m of any tunnel.
- (xiv) Within 20m of any parking place.
- (xv) Within 20m of a bus stop sign or within 10m of the bus stop road markings 1047 and 1048, or the public light bus or taxi stand marking 1049.
- (xvi) Within 20m of the summit of a gradient of more than 10%.

5.4.3.8

Road humps should not normally be installed on roads forming part of a public transport route, because of the possible delay and discomfort caused to passengers. However if it is agreed after consultation with the appropriate public transport company or companies to install road humps, the height of any road hump should not be greater than 75mm.

- 5.4.3.9 It is generally advisable, in order to ensure vehicle speeds are not excessive when approaching a road hump, that the road where humps are installed incorporate wherever possible one or more of the following features :
- (i) Vehicles enter the road through a junction where they have to change direction by not less than 70 degrees with an inner turning radius of not more than 25m.
 - (ii) There is a bend along the road which changes the direction of vehicles by not less than 70 degrees with an inner kerb radius of not more than 25m.
 - (iii) The road is a cul-de-sac.
 - (iv) Access is restricted to certain types of vehicles only.
 - (v) The road does not provide a through route between major roads.
 - (vi) Side road junctions along the humped road are generally at right angles to the humped road.
- 5.4.3.10 If the road under consideration does incorporate one or more of the features referred to in paragraph 5.4.3.9 then to further ensure that approach speeds are not excessive it is suggested that road humps should be located at a distance from the feature in accordance with the following :
- (i) At or about 30m of the entry junction.
 - (ii) Approximately 30m beyond a horizontal bend, though this may need to be increased depending on whether the road hump warning traffic sign 539 can be located satisfactorily with sufficient visibility distance.
 - (iii) Approximately 30m from the closed end or turning area of a cul-de-sac, so that vehicles coming from that direction are not encouraged to increase their speed substantially.
 - (iv) Approximately 30m from the point where the restriction on vehicle access applies.
- 5.4.3.11 The use of road humps on roads with steep gradients is not recommended as in the uphill direction slower vehicles can find them difficult to negotiate and under adverse weather conditions in both directions of travel they are potentially dangerous.
- 5.4.3.12 It is relevant that noise will be generated when vehicles pass over the humps and vehicles such as empty or lightly laden goods vehicles can be a considerable nuisance in this respect, and this should be taken into account before road humps are installed.
- 5.4.3.13 Road markings in accordance with Diagram 5.4.3.2 must be laid at the approaches to a road hump, using suitable reflective material.
- 5.4.3.14 The warning line pattern is that generally associated with higher speed roads but is used to ensure that warning line mark can be laid across the road hump.
- 5.4.3.15 The warning lines should commence from at least the point where the warning sign, traffic sign 539 "Road Hump or Series of Road Humps Ahead", is erected, and in the case where a road hump is situated within 30m of a road junction, the warning line pattern should commence from the junction.
- 5.4.3.16 If there are stopping restrictions where humps are installed the edge line markings can be omitted, as the appropriate yellow line markings can substitute for these.

- 5.4.3.17 Traffic sign 539 "Road Hump or Series of Road Humps Ahead" should, subject to paragraph 5.4.3.18 be generally placed approximately 45m in advance of a road hump, or where a series of road humps are used in advance of the first or leading road hump, and the sign should have a minimum clear visibility distance of approximately 60m.
- 5.4.3.18 Where a road hump or series of humps commences at or within 50m of a junction, the traffic sign should be erected not closer than 5m and not greater than 15m from that junction.
- 5.4.3.19 Where a series of road humps are used, the supplementary plate 784, "For 1 km", or a suitable equivalent, should be used in conjunction with the traffic sign, to indicate the extent of the series of humps.
- 5.4.3.20 It is not necessary to use intermediary warning signs with a series of humps, other than when a side road junction occurs within the series. In these locations the traffic sign should be erected without supplementary plate, traffic sign 784, at the normal siting distance in accordance with paragraph 5.4.3.17, if this is possible, or if not in accordance with paragraph 5.4.3.18.

5.4.3.21

Diagram 5.4.3.3 shows an example of a road hump installation.

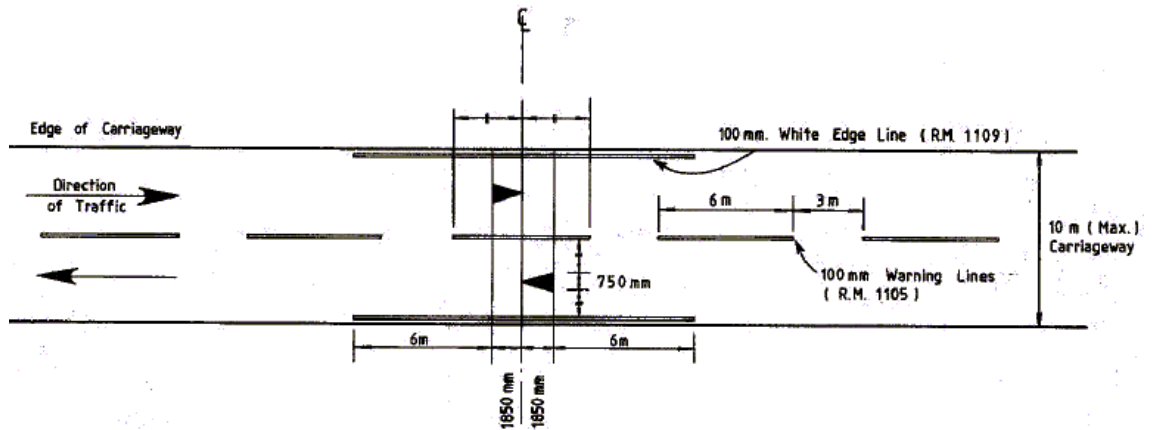
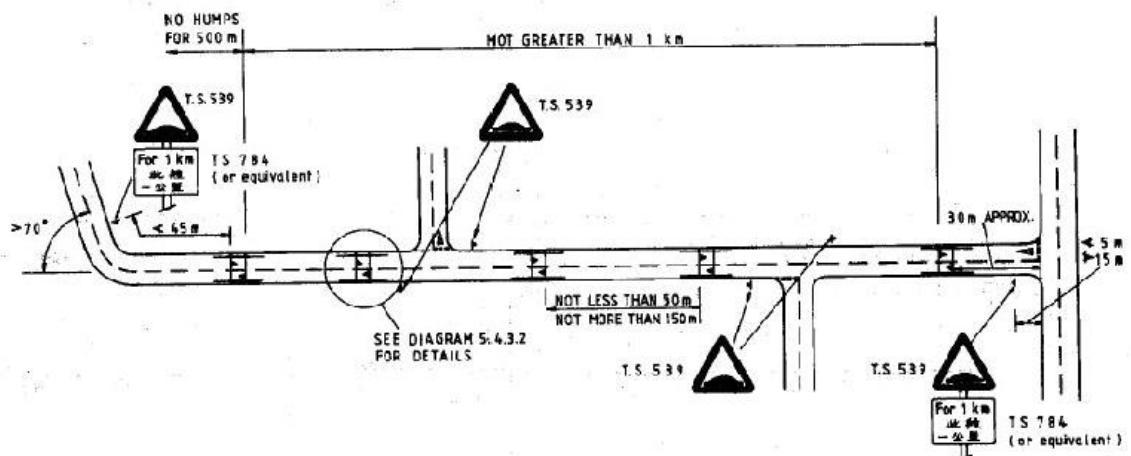
DIAGRAM 5.4.3.2 : ROAD MARKINGS FOR ROAD HUMP INSTALLATIONS**DIAGRAM 5.4.3.3 : ROAD HUMP INSTALLATION****5.4.4 Transverse Yellow Bar Markings**

- 5.4.4.1 This type of "additional speed control device", consists of 90 No. markings, 600mm in width laid at right angles to the carriageway over a 400m length, with the spacing between successive markings becoming progressively smaller as the hazard is approached. A modified pattern of transverse yellow bar markings is introduced along deceleration lanes leading to slip roads of roads with speed limits of 70 km/h or above to alert motorists of the change in speed limit.
- 5.4.4.2 The effect of the markings is to distort the driver's perception as to the actual speed being travelled thus creating the impression that the vehicle is seemingly "speeding up" and so encouraging the driver to slow down.
- 5.4.4.3 This type of "additional speed control device" can be used on high speed approaches to roundabouts, toll booth, slip roads etc.

- 5.4.4.4 Transverse yellow bar markings should only be considered for road sections which meet all the following requirements:
- (i) single carriageway with one way traffic or dual carriageway roads;
 - (ii) being subject to a speed limit of not less than 70 km/h; and
 - (iii) being preceded by at least 1 km of single carriageway with one way traffic or 1 km of dual carriageway, with no major intersections or severe bends before the start of the markings for either situation.
- 5.4.4.5 The markings should be used at sites where they can contribute positively to safety. In general, such markings should not be used on main carriageway as a device for warning of lowering speed limit or for speed control, unless where accident statistics indicate that speeding or speed misjudgement was a predominant factor of the traffic accidents and endorsement by the respective Chief Traffic Engineer should be obtained prior to its use. For markings already being used along main carriageways, the Chief Traffic Engineers should critically review whether they can meet the above criteria and are really necessary.
- 5.4.4.6 Details of the actual marking and the setting out procedures are given in Volume 3, Chapter 5 and should be followed. Modifications to the arrangement to obtain a shorter length of markings will not achieve the desired effect and therefore is generally not recommended. However where there is insufficient length for the full set of markings to be laid on a slip road, some reduction is acceptable, but there should be at least 50 No. of the transverse marks, i.e. D1 to D50, in accordance with Table 5.6.5.1 of Volume 3, Chapter 5.
- 5.4.4.7 The markings must be laid in a suitable durable reflective material, and it is relevant to note that assuming a two lane approach some 360 square metres to 400 square metres of material will be required. Because of the large amount of material used the initial cost of providing the markings will be relatively high. To remain effective, replacement will be required every two to three years, and on some roads even more frequently. Therefore, it is essential to justify this expense by properly demonstrating the usefulness of the markings at any particular location.
- 5.4.4.8 To assist surface water drainage, each end of the bar should be terminated about 100mm from the edge of the carriageway or the edge line marking if provided. Bars should not be extended across hard strip or hard shoulders as this would give the impression that these are traffic lanes.
- 5.4.5 Rumble Areas**
- 5.4.5.1 Rumble areas are patches of rough coarse road surface which produce aural and tactile stimuli inside a vehicle with the intention of alerting drivers to a particular hazard ahead.
- 5.4.5.2 Research in the UK TRRL Report 800 has however indicated that although these devices may reduce the number of accidents occurring at a particular hazard they do not necessarily reduce the approach speed of vehicles, and therefore if the latter is required these type of devices may not be appropriate.
- 5.4.5.3 Appropriate material for the patches has found to be 13-19mm roadstone set onto the road surface using epoxy resin, and further details of this can be found in TRRL Report 800.
- 5.4.5.4 Six patches should normally be used to form the complete rumble area, which should normally end at least 100m before the hazard.
- 5.4.5.5 Rumble areas are generally only appropriate for two way 2-lane carriageways because of possible dangers that might occur with vehicles overtaking and simultaneously passing over the patches, however they have been used in other countries on a dual carriageway approach to a round about.

5.4.5.6 It is only necessary to lay patches on the approach lane to the hazard and not the full width of the carriageway or carriageways as vehicles in the opposite direction are proceeding away from the hazard. However this can in the case of single carriageway roads sometimes lead to vehicles crossing over onto the adjacent lane for opposing traffic in order to avoid the rumble areas, and therefore care has to be taken as to the siting of rumble areas that there is adequate visibility. Alternatively it maybe appropriate to consider the use of double white lines to confine vehicles to their lanes.

5.4.5.7 The precise method of determining the length of the patches and the spaces between can be found in TRRL Report 800, which assumes a linear deceleration between points 250m and 100m before the hazard and calculating the positions and lengths of the patches accordingly. However conditions in the Territory are such that uniform speeds can generally be assumed. Based on this assumption Table 5.4.4.1 gives the length of the patches and spaces between them for various 85th percentile approach speeds.

Table 5.4.4.1
Patch Lengths and Spacing

<u>85th percentile speed</u> (km/h)	<u>Patch Length</u> (m)	<u>Space between patched</u> (m)	<u>Rumble strip Length</u> (m)
60	5.69	10.96	100
70	7.08	12.36	116.64
80	8.47	13.75	133.3
90	9.9	15.1	150

5.4.5.8 Using Table 5.4.4.1 appropriate patch lengths can be obtained by rounding the actual 85th percentile speed to the nearest 85th percentile speed given in the Table. The first patch is positioned at 100m from the hazard with the five other patches spaced in accordance with the distances given in Table 5.4.4.1. Some adjustment of the first patch can be made where it is considered appropriate, i.e. because of the presence of a bend or similar but this adjustment should not generally result in the patch nearest to the hazard being located closer than 80m or farther away than 150m. Further patches can also be added if considered appropriate but this should not generally result in more than eight patches being used.

5.4.5.9 On the approach to the rumble area, traffic sign 434, “Uneven road” should be erected in accordance with Table 2.2.2.1, of Chapter 2, Volume 3. It may also be appropriate to use the supplementary plate, traffic sign, 784, or equivalent, indicating the distance over which the area extends.

5.4.5.10 Noise can be generated by the rumble areas and the possible effect of this will need to be evaluated if there are any residential developments, Hospitals or Schools, adjacent to the road.

5.4.5.11 It should also be noted that the cost of installation and subsequent maintenance of rumble areas can be relatively high, and therefore it is necessary to ensure that this expense is justified before any rumble areas are agreed to.

5.4.6 Rumble Strips

5.4.6.1 Rumble strips are a further aural and tactile warning device very similar to rumble areas, but rather than broad patches consist of narrow strips placed at regular intervals, normally used on single carriageway roads, but may in certain circumstances be appropriate on dual carriageway roads.

- 5.4.6.2 Various types of material have been used including raised concrete strips, but these are not recommended. However, strips formed from 13mm-19mm road stone chippings set onto the road surface by using epoxy resin have had some degree of success and are generally recommended where it is considered that rumble strips should be provided.
- 5.4.6.3 The rumble strips formed from roadstone chippings should be 1m wide spaced at intervals of 7m apart, with at least 20 No. being used, and laid only on the approach to the hazard.
- 5.4.6.4 The location of the rumble strips should be in advance of any warning sign warning of the hazard and generally not closer than 30m to such a sign.
- 5.4.6.5 Rumble strips like rumble areas do not necessarily reduce the approach speed of vehicles, and in fact evidence is that only slight reductions in speed are obtained. However they do act a "wake up" device, which does alert drivers to the hazard ahead and in this respect have been found to reduce accidents.
- 5.4.6.6 Rumble strips can cause problems in respect of the noise generated and the vibration effect caused. In the case of the former careful consideration must be given regarding the use of rumble strips if there are residential developments or hospitals or schools nearby, particularly if unladen goods vehicles are likely to use the route as these can be the worst offenders. In respect of the vibration effect these can cause goods to be dislodged, and given that many goods vehicle operators do not pay proper attention to the loading of their vehicles it may not be advisable to use rumble strips on route heavily used by these vehicles.
- 5.4.6.7 Rumble strips of whatever type should not be used in marginal strips or hard shoulders to warn of adjacent barrier fences. Apart from the fact they interfere with the drainage and collect rubbish, it is far safer to leave the marginal strip vacant of any kind of obstruction. Additionally in the event of a vehicle breaking down there is less likelihood of the vehicle being moved onto the marginal strip because of the obstruction caused by the rumble strips. Also it is likely to cause occupants of the vehicle to walk along the carriageway rather than the marginal strip to avoid the rumble strips.
- 5.4.6.8 The provision of narrow transverse rumble strips to separate a carriageway from an adjacent tram lane or similar, or to separate merging/diverging carriageways is not recommended, as these are of doubtful value and may in fact increase the potential for an accident to occur rather than decrease it. It is also relevant that they do not actually prevent a vehicle straying onto the supposedly "protected" area and depending on the type of rumble strip and the type of vehicle they could cause the vehicle to be trapped in that area even if only momentarily. These types of rumble strips can also be potentially dangerous to cyclists and motor cyclists.
- 5.4.6.9 At the start of the rumble strips, described in paragraphs 5.4.6.2 and 5.4.6.3 traffic sign 434 "Uneven road" should be erected in accordance with Table 2.2.2.1 of Chapter 2, Volume 3, together with the supplementary plate, traffic sign 784, indicating the distance over which the rumble strips extend.
- 5.4.6.10 As with rumble areas, drivers on the approaches to rumble strips may in order to avoid them, travel on the offside of the road where strips have not been laid. If this is likely to cause a problem the use of double white lines to prevent this may need to be considered.
- 5.4.6.11 As with rumble areas, rumble strips can be relatively expensive to install and maintain and therefore it is necessary to ensure that this expense is fully justified before agreeing to the installation of rumble strips.

5.5 Public Transport On-street Stopping Places

5.5.1 Detailed Design Requirements

5.5.1.1 The detailed design requirements and dimensions for all types of public transport on-street stopping places are given in the various chapters of Volume 9.

5.5.1.2 The purpose of this section is merely to bring to the attention of the designer the various facilities that may need to be considered.

5.5.2 General Considerations

5.5.2.1 The necessity to provide on-street public transport stopping places will depend very much on the type of highway scheme that is being designed, but early consultation with the appropriate Transport Operations Divisions of the Transport Department should be made to ascertain whether any or all of the following are required :

- (i) Franchised Bus Stopping Places;
- (ii) PLB Stands or Stopping Places;
- (iii) Taxi Stands;
- (iv) Non-franchised Bus Stopping Places.

5.5.2.2 On-street public transport stopping places should not normally be provided on Trunk Road, Primary Distributor Roads and Rural Roads having no frontage access. Consideration will need to be given as to where appropriate and convenient stopping places can be located adjacent to these routes.

5.5.2.3 Bus stopping places should normally not be provided on slip roads as this can interfere with the movement of other traffic, and the presence of pedestrians along these roads where traffic speeds are still relatively high may be detrimental to road safety. However, in certain situation there may be no alternative other than to locate the bus stop along a slip road. In these cases although each situation will need to be considered separately it will be important to ensure that the following points are taken into account :

- (i) That buses do not stop on the running carriageway;
- (ii) That buses emerging from the bus stop can do so safely, and in this respect that the driver of the bus can adequately see through his rear mirror vehicles approaching in the stream the bus is to be driven into;
- (iii) That pedestrians can safely reach and leave the bus stop area, preferably without crossing the slip road at grade;
- (iv) That pedestrians can safely wait at the bus stop and are discouraged from wandering onto the slip road.

- 5.5.2.4 In terms of providing convenient stopping places for franchised buses adjacent to high speed roads, consideration should be given early in the design stage as to whether bus only slip roads, perhaps as a link between the main slip roads can be provided. However such facilities should not be provided for red minibuses and any stopping places for these should be situated away from any slip roads or major junctions.
- 5.5.2.5 Taxi and Public Light Bus stands will normally only be appropriate for categories of road of local distributor road status or less.

5.6 Landscaping

5.6.1 General

- 5.6.1.1 Considerable benefit can be obtained in terms of the general appearance, and lessening the impact of a highway project scheme on the surrounding environment by the use of landscaping techniques. Planting, if properly designed, can reduce visual impacts such as visual intrusion, monotony and glare. It can also help to break down noxious gas emitted from vehicles. In addition, landscape earth bunds can serve as noise mitigation measure. Furthermore, landscape planting can be used to create a green environment for pedestrians by creating visual interest, reducing temperature of roads by providing shade and absorbing radiation from the sun, enhancing humidity of the air etc. The planning and design of pedestrianisation scheme are covered in TPDM Volume 6 Chapter 10.
- 5.6.1.2 Early inclusion of landscaping requirement both in the feasibility study of a road project and at the planning/design stage is necessary if the full benefits of suitable landscaping are to be obtained. Landscape works which may include tree planting should be designed as an integral part of the transport corridor. Any additional land provision for landscaping may be identified and allowed for. The planting area shall be free of disturbance from underground utilities. Furthermore, tree preservation should be thoroughly considered at the planning/design stage of the works.
- 5.6.1.3 Consultation with the relevant body should also be carried out in respect of any landscaping adjacent to overhead cables of tram, or vehicles of the MTR Corporation Limited.

5.6.2 Aspects Affecting Highway Design and Operations

- 5.6.2.1 It is beyond the scope of this manual to give landscaping design details. However, landscaping should be provided with full consideration of highway design and just as importantly road safety. Wherever possible, access to the landscaped areas from the carriageway of the expressway should be avoided.
- 5.6.2.2 Planting should be provided in areas where they do not interfere with the sight line and visibility requirements in respect of the following aspects :
- (i) Volume 2, Chapter 3, Section 3.3.5 for sightlines along a road;
 - (ii) Volume 2, Chapter 4, Section 4.3.8 for visibility splays at junctions;
 - (iii) Volume 2, Chapter 4, Section 4.5.12 for visibility on and at the approaches to roundabouts;
 - (iv) Volume 2 Chapter 6, Section 6.4.2 for visibility envelope for road side signs; and
 - (v) Volume 3, Chapter 3, Section 3.2.5 for visibility of directional signs.

On the central reserve of a dual carriageway approach to a roundabout and the central island of roundabout with diameter less than 10m where tree planting is restricted for preservation of visibility, groundcovers, turf or low shrubs can be planted. In some cases, it may be acceptable to plant a small upright tree/palm with narrow trunks. If future growth of any plants will interfere with sight lines, the planting should be initially set far enough back to ensure that they will not cause any interference problem.

- 5.6.2.3 It is important that any planting does not obscure traffic signs and light signals. Whilst obviously arrangements can be made for cutting back overhanging branches it is preferable that account of this is taken in the design stage and planting should be provided sufficiently away from the traffic signs and light signals with the clear visibility distances given in Chapters 2 and 3 of Volume 3.

- 5.6.2.4 For expressway and other high speed roads, only such low plant can be planted within the triangular visibility envelope in front of all road side signs to ensure that the signs can be clearly read by approaching traffic. The visibility distances for directional signs and the visibility envelope are given in Chapter 6 Section 6.4.2. It is also important that the planting does not hinder the operation of speed enforcement cameras and traffic surveillance equipment/facilities, such as CCTV cameras, automatic incident detectors, police observation spots etc.
- 5.6.2.5 The safe operation of the road as well as the method of maintaining any planting or other elements associated with landscaping should be considered at the design stage. In this respect, the maintenance and/or tree felling authorities for landscape hardworks and softworks should be consulted on the proposals before they are implemented and preferably during the design process.
- 5.6.2.6 Lane closure for general road maintenance and cleansing is regularly carried out by Highways Department for primary distributors and high speed roads. The horticultural maintenance authority may also take this opportunity to carry out the planting maintenance works.
- 5.6.2.7 In the planting design for central reserve, visibility shall not be interfered and the width of central reserve shall be suitably widened if necessary to provide sufficient space for the plants to grow to their full size without encroaching on the carriageway. If future growth of plants will interfere with sight lines, the planting should be initially set far enough back to ensure that they will not cause any interference problem. Watering of plants from the fast lane will not be permitted as it will cause traffic disruption. Therefore, an automatic irrigation system for watering should be installed unless the type of planting does not require watering to avoid maintenance vehicles having to stop on the carriageway. Alternative access must be provided to the central reserve or arrangements made for the utilisation of cyclic lane closure. In this respect it may be possible to provide a pedestrian access for personnel from an elevated road or footbridge spanning over the carriageway in question. Care must also be taken to ensure that on curved sections of road, any planting in the central reserve does not obscure forward visibility for traffic in the fast lane, and if to achieve the required safe stopping distance it is necessary that only low shrubs or small upright tree/palm with narrow trunks can be planted on the central reserve within the sight line envelope.
- 5.6.2.8 If tree planting is planned for verges, embankment, cuttings or similar, along Trunk Roads, expressways or Primary Distributor Roads or Rural Roads, it will be necessary to provide a piped water supply so that any watering required for the establishment of the trees can be taken from this supply rather than water tankers parked at the side of the road. However, the piped water supply is considered not necessary for small isolated planting areas, such as toe planters to slopes and remote rural areas, or hydroseeded areas or native woodland planting for which water supply from natural rainfall should be sufficient.
- 5.6.2.9 Where planting is agreed in respect of verges on expressways, Trunk Roads and Primary Distributor Roads, the 3m verge incorporating a marginal strip and provided in accordance with Section 3.4.9 of Volume 2 Chapter 3, must be kept clear of all trees, shrubs, hedges or similar, as this area is required for vehicles to pull off in the event of a breakdown.

- 5.6.2.10 On slip roads or flyovers, because of the tight geometry usually employed, it is not desirable from a road safety point of view for vehicles to be parked or personnel to be working from the carriageway, and if planting adjacent to these is required consideration must be given as to how these actions can be avoided in respect of any future maintenance operations before such planting is agreed.
- 5.6.2.11 Landscaping designs should ensure, as far as possible, that any proposed planting or other landscape features and any subsequent growth of the plants would not induce severe interference and disruption to existing road lighting, CCTVs and Red Light Cameras etc, and their subsequent operation and maintenance. If the existing road lighting is being shaded by the subsequent growth of plants, the maintenance agents for trees or light poles should carry out appropriate measure to rectify the situations. It can be in the form of proper tree works to lift the tree canopy or to remove branches causing disruption, or modification and relocation of the existing light pole.
- 5.6.2.12 Where it is accepted that the maintenance of any planting or other landscape features, has to be achieved from the carriageway, it is imperative that the advice on the signing and other procedures in the Code of Practice for the Lighting, Signing and Guarding of Road Works is followed, and account of this is taken in the planning of maintenance programmes. In the case of expressways, this will entail the closure of a lane or lanes if vehicles are to be stopped on the carriageway. Failure to follow the procedures may prejudice the safety of personnel engaged in maintenance work and may also make them liable to prosecution. Consultation with the Police and the Highways and Transport Departments is also required where works are to be carried out on or from the carriageway.
- 5.6.2.13 In landscaping design, the effects of planting and its subsequent growth on vehicular traffic should be considered in conjunction with pedestrian traffic. Raised planters adjacent to footway can provide a very attractive feature and improved pedestrian environment, however additional footway width should be provided to allow for any shrubs or bushes in the planters over the footway as they will reduce the effective footway width. For more details, refer to Volume 6 Chapters 8 and 10. To ensure that the planters in the vicinity of crossings will not obscure pedestrians, in particular children, from the view of approaching vehicle drivers, nor interfere sight lines of pedestrians to such vehicles, the overall height of the planters including shrubs should not exceed 0.5m within 30m on the approach to a crossing.
- 5.6.2.14 Landscaping designs on highway structures should ensure that any planting or subsequent growth of plants would not affect the integrity of the structures nor affect their inspection and maintenance. Except landscape plantings which have been properly considered in the design stage, only creepers grown on dedicated frames and small shrubs in portable planters are allowed on highway structures. Direct placement of soil onto structural elements which are not designed for this use must be avoided as they will obstruct the inspection and maintenance of highway structures. Particular attention must be paid to root growth and irrigation seepage that are detrimental to the well-being of structural elements which are not installed with suitable protections.
- 5.6.2.15 For expressways, consideration must be given when landscape proposals include the planting of trees, that future growth will not result in them becoming a substantial obstruction which would necessitate the provision of protective barrier fences. In this respect, groundcovers, turf, low shrubs or other suitable species may be considered to be planted within 5m from the rear of the shoulder.
- 5.6.2.16 Landscape designs which require frequent and regular maintenance whether by persons on foot or in slow moving vehicles, increases the risk to operatives and other road users, whatever warning signing procedures are adopted, and must therefore be avoided, if possible.

5.6.3 Guidelines for Considering Tree Planting Proposal

5.6.3.1 Tree planting proposals should be considered flexibly to promote greening opportunity whilst ensuring road safety. The following serve as a checklist only and the traffic engineering requirements should be checked for each tree planting location :

- (i) Trees should be planted clear of traffic light signals and/or traffic signs to ensure their visibility. Furthermore, they should not be planted in such locations as to hinder the operation and maintenance of speed enforcement cameras and traffic surveillance equipment/facilities, such as CCTV cameras, automatic incident detectors, police observation spots, etc.
- (ii) Trees should be planted at least 5m (measured along the carriageway) away from the approach side of a pedestrian crossing, run-in or a bus stop.
- (iii) Trees should be planted at least 10m (measured along the carriageway) away from a road junction.
- (iv) A minimum lateral clearance of 500mm should be maintained between the outside part of the tree trunk including tree guard and kerbside. This dimension should be increased to 1.0m for high speed roads with a design speed or speed limit of 70 km/h or above.
- (v) Adequate footpath width should be maintained to cater for pedestrian traffic. Please refer to Volume 2 Chapter 3 Section 3.4.11 for the minimum width of clear footpath to be maintained.
- (vi) For avenue/street tree planting the trees should normally be spaced at a minimum distance of 5m from centre to centre. However, such requirement is not applicable if the trees are planted at the back of footpath or in the central reservation.
- (vii) Partial overhang of tree planting should have a minimum height clearance of 5.5m. Overhang on footpath and cycle track should have a minimum height of 2.5m.
- (viii) Trees planted within visibility splays should be selected with a high canopy and slender trunk to ensure that only minimal obstruction of driver vision is effected by the stem.
- (ix) Trees should be planted at least 5m from existing street lighting to avoid shading effect.
- (x) Agreement should be obtained from the relevant maintenance authority for the future maintenance of tree, including trimming of branches, felling and transplanting if necessary due to traffic management schemes. In this respect, Development Bureau Technical Circular (Works) No. 6/2015 (or updated versions) can be referred.

5.6.3.2 Tree planting, including small canopy trees, upright tree/palm with narrow trunks, turf, groundcovers or low shrubs, is allowed along kerbside as long as they will not cause sightline and visibility problems. Alternatively, trees can be planted away from the kerb, such as at the back of footpath.

5.6.3.3 Trees should not normally be planted in areas which will be affected by planned road improvements in the foreseeable future unless they are transplantable or in containers. However, temporary landscape that may consist of hydroseeding and/or tree/shrub planting may be required to mitigate the potential landscape and visual impacts. The scope of temporary landscape works would be advised by the relevant authority on a case by case basis. The authority responsible for the new works/development shall be responsible for the application for the removal of the trees when the need arises in future.

5.7 Lighting and Drainage

5.7.1 Lighting

5.7.1.1 Adequate lighting must be provided to all public roads. The advice of the Lighting Division of Highways Department on the design of lighting should be obtained.

5.7.1.2 Lighting columns are best located at the back of the footpath or verge to reduce obstruction and give maximum and give maximum clearance.

5.7.2 Drainage

5.7.2.1 Adequate drainage of pavement and storm water must be provided and the advice of Highways Department (or the maintaining authority if not HyD) should be obtained on exclusive highway drainage, and that of Drainage Services Department for carrier drains or main drainage.

TPDM Volume 2 Chapter 6 – Expressways

6.1 References

1. *Transport Planning Design Manual* Volume 3, Chapter 3 - Directional Signs
2. *Transport Planning Design Manual* Volume 2 Chapters 2, 3 and 4
3. Highways Department, *Road Surface Requirements for High Speed Roads*, Road Note 5, 1983
4. THE DEPARTMENT OF TRANSPORT, *Road Geometry: Highway Link Design*, Departmental Standard TD 9/93
5. FREEMAN FOX, WILBER SMITH AND ASSOCIATES, *Hong Kong Long Term Road Study*
6. MAUNSELL CONSULTANTS ASIA, *Comprehensive Transport and Surveillance Study 1976*
7. THE DEPARTMENT OF TRANSPORT, *Withdrawal of Motorway Design Memorandum*, Departmental Advice Note TA 26/81
8. THE DEPARTMENT OF TRANSPORT, *Police Observation Platforms on Motorways*, Departmental Advice Note TA 66/95
9. *Report of the Working Sub-group of WITSS*, Expressway Legislation 1986
10. THE DEPARTMENT OF TRANSPORT, *Cross Sections and Headroom*, Departmental Standard TD 27/86
11. THE DEPARTMENT OF TRANSPORT, *Mobile or Short Duration Static Lane Closures Using Vehicle Mounted Signs*, Departmental Advice Note TA 55/87
12. THE DEPARTMENT OF TRANSPORT, *Mobile or Short Duration Static Lane Closures Using Vehicle Mounted Signs*, Departmental Standard TD 29/87
13. THE DEPARTMENT OF TRANSPORT, *Treatment of Gaps in Central Reserve Safety Fences*, Departmental Advice Note TA 45/85
14. THE DEPARTMENT OF TRANSPORT, *Highway Features: Roadside Features*, Departmental Advice Note TA 57/87
15. THE DEPARTMENT OF TRANSPORT, *Junctions: Layout of Grade Separated Junctions*, Departmental Standard TD 22/92
16. Highways Department Technical Circular No. 29/97
17. Highways Department Technical Circular No. 5/91
18. Highways Department, *Code of Practice for the Lighting, Signing and Guarding of Road Works*

6.2 Introduction

6.2.1 General

- 6.2.1.1 Expressways, which will be designated as such under Expressways Legislation, are roads connecting the main centres of population within the Territory. They must be to dual carriageway standard with appropriate alignment, and widely spaced grade separated junctions. No frontage access will be allowed and the provision of intermediate grade separated junctions to allow for specific developments should not be permitted. Pedestrians, cyclists, learner drivers, hand carts and animals will be prohibited and all pedestrian cross movements must be fully segregated. The stopping of vehicles, other than in an emergency or similar, will generally be prohibited and therefore lay bys, or other off road stopping facilities, should not be provided, except for appropriately spaced police observation platforms and purpose designed service areas. A hard shoulder should be provided adjacent to the slow lane of each carriageway throughout the length of the Expressway. The hard shoulder must be of the same construction as the adjacent carriageway so that it can be utilised as a traffic lane in emergencies or for maintenance purposes.
- 6.2.1.2 In the hierarchy of road types referred to Chapter 3 of this Volume, an Expressway may be formed from a trunk road.
- 6.2.1.3 At each grade separated junction the roads connecting the Expressway with the minor road system are referred to as "slip roads".
- 6.2.1.4 Roads connecting one Expressway with another Expressway are "link roads" and must be designed to full Expressway standards.
- 6.2.1.5 An overbridge is a bridge that spans across an Expressway.
- 6.2.1.6 The near side lane of each carriageway adjacent to the hard shoulder is the "slow lane" whilst the off side lane of each carriageway next to the central reserve, is the "fast lane". On carriageways having three or more lanes, the intermediate lanes will be referred to as the "middle lane or lanes".
- 6.2.1.7 Roads are designated as Expressways only if they meet the required Expressway standards. Roads should not be incorporated into the Expressway system as isolated sections. Therefore until at least a major part of it can be designated as an Expressway, such sections should not be included as part of the network. In this respect a major part should be regarded as, at least, that section of a route connecting two major areas of population.
- 6.2.1.8 Route numbering for Expressways must follow the Territory route numbering system as detailed in Chapter 3 of Volume 3 of this Manual.
- 6.2.1.9 The provision of bus lanes, exclusively for the use of franchised buses, is not generally appropriate for Expressways, as these will interfere with weaving movements at junctions and complicate enforcement in respect of excluding medium and heavy goods vehicles from the fast or outer lane of a three lane dual carriageway. However, in the event that the movement of public transport is impeded on an Expressway, an exclusive bus lane is still considered desirable if no alternative solution can be worked out.

6.2.1.10

The provision of emergency crossings along Expressways should generally be in accordance with Section 3.4.8 of Chapter 3 of this Volume. However because of the higher operational speeds prevailing along these roads, careful consideration should be given to the provision of such facilities, as the gaps create particular hazards in the respect that they increase the risk of vehicles encroaching onto the opposite carriageway and that in the event that a vehicle strikes the end piece of any barrier in the central reservation, serious injury or fatality can result to the occupants of that vehicle. If on Expressways it is decided that emergency crossings are required they should preferably not be spaced closer than 3km apart and not be located near or at the bend of the Expressway. It should also be noted that the standard 10m width is totally inadequate in the event that contra flow working is anticipated, but it is not appropriate to increase this width to meet this contingency, see Section 3.9.3.

6.3 Expressway Design Standards

6.3.1 Design Speed

6.3.1.1 The concept and assessment of design speed is set out in Section 3.3.2 of Chapter 3 of this Volume. On Expressways the elimination of access other than at interchanges, the prohibition of use by pedestrians, together with the more generous alignment, gives confidence to the driver and higher operating speeds will result. It is essential therefore that the design speed adopted should be in the highest band possible for dual carriageways.

6.3.1.2 Table 6.3.1.1 provides details of appropriate design speeds for Expressways in Rural and Urban situations, for the main route, link roads, and slip roads.

Table 6.3.1.1
Expressway Design Speeds (km/h)

	<u>Main Routes</u>	<u>Link Roads</u>	<u>Slip Roads</u>
Rural Conditions	100	100	80 or above
Urban Conditions	80 or above	80	50 or above

6.3.1.3 With regard to Table 6.3.1.1 the aim should be to adopt the highest design speed possible, commensurate with economic design. It is not appropriate to vary design speeds along a route because of localised difficulties, but in these situations consideration should be given to varying particular design elements such as horizontal curvature or sight distance so that instead of desirable minimum values, lesser values and if necessary, absolute minimum values are provided. However it is stressed that at junctions along Expressways, design elements should not be less than desirable minimum values except where an Expressway passes from rural to urban conditions, and to avoid excessive costs it may be appropriate to adopt standards less than the desirable minimum to maintain the same design speed throughout the route. If for any reason it is proposed to depart from the standards given in Table 6.3.1.1 full justification must be provided and approval from the Transport Department must be obtained.

6.3.1.4 In order to provide a surface commensurate with the higher design speeds adopted, Expressways should normally, but see paragraph 6.3.1.7, have a friction course surfacing, which is an open graded porous bituminous material described and set out in the Highways Department Road Note 5.

6.3.1.5 The use of friction course surfacing is generally recommended for Expressways as this material has amongst others the following properties compared with continuously graded bituminous materials :

- (i) minimisation of road spray from vehicles during and after raining;
- (ii) greatly increased texture depth;
- (iii) reduction of the potential for vehicles to aquaplane;
- (iv) improved skid resistance at high speeds.

6.3.1.6 The purpose of friction course surfacing is to produce a very permeable material with continuous voids so that water can percolate into the pavement and disperse towards the drainage systems at the pavement edge.

6.3.1.7 It should be noted that friction course is generally suited and applied to free flow conditions with relatively gentle gradients. It is therefore advisable to omit it on slip roads with gradients or where there may be queuing and/or stop/start conditions, and free flow conditions cannot be achieved.

6.3.2 Horizontal and Vertical Alignment

6.3.2.1 The standards for horizontal and vertical alignment are set out in Chapter 3 of this Volume. Other than in the particular circumstances mentioned in paragraph 6.2.1.3, and only if it is absolutely necessary, radii of horizontal curvature should not be less than R4 for new roads. Similarly for vertical curvature 'K' values should not be less than the Desirable Minimum.

6.3.2.2 The enhanced free drainage properties of friction course are best achieved where the carriageway has both crossfall and longitudinal fall. Sections of road with zero or small gradients should be kept to a minimum and curves should be phased so that changes in superelevation occur at places where there is a reasonable longitudinal gradient.

6.3.3 Cross Section

6.3.3.1 Diagrams 6.3.3.1 to 6.3.3.8 illustrate cross sections for Expressways in rural and urban situations, for the main line and link roads, whilst Diagrams 6.3.3.9 and 6.3.3.10 illustrate cross sections for Expressway slip roads.

6.3.3.2 The cross sections in Diagrams 6.3.3.1, 6.3.3.2, and 6.3.3.4 to 6.3.3.9, represent, ignoring additional land that might be required for road signs etc., the desirable minimum cross sections which should be attained as far as possible.

6.3.3.3 Diagrams 6.3.3.3 and 6.3.3.10 indicate absolute minimum cross sections for both the main line and slip roads respectively, which may be used in certain circumstances subject to the conditions expressed below.

6.3.3.4 The dimensions for carriageways, and marginal strips, should be regarded as minimal and should not be reduced. Two lane carriageways, 7.3m in width, should only be provided on Expressways, other than along slip roads or link roads, in exceptional circumstances.

6.3.3.5 The 3300mm nearside hard shoulder provides an essential reserve in respect of :

- (i) broken down vehicles;
- (ii) temporary storage for vehicles following a traffic accident;
- (iii) working space for maintenance operations;
- (iv) space for traffic police to "pull in" a vehicle;
- (v) access for emergency vehicles to accident scenes; and
- (vi) temporary lane for traffic when maintenance works is taking place on other lane.

6.3.3.6 Hard shoulders should be provided on all sections of the Expressway including parts :

- (i) beneath structures;
- (ii) on bridges or viaducts;
- (iii) on embankment;
- (iv) in cuttings.

6.3.3.7 The hard shoulder must be kept unobstructed, and in particular kept clear of :

- (i) road furniture;
- (ii) road lighting columns;
- (iii) road signs;
- (iv) landscape planting including ground cover;
- (v) earth mounding;
- (vi) kerbs or raised kerbs;
- (vii) open drainage channels; and
- (viii) police observation platform.

DIAGRAM 6.3.3.1 : RURAL EXPRESSWAY TYPICAL CROSS SECTION ON EMBANKMENTS

A. WITH LONGITUDINAL ROAD DRAINAGE

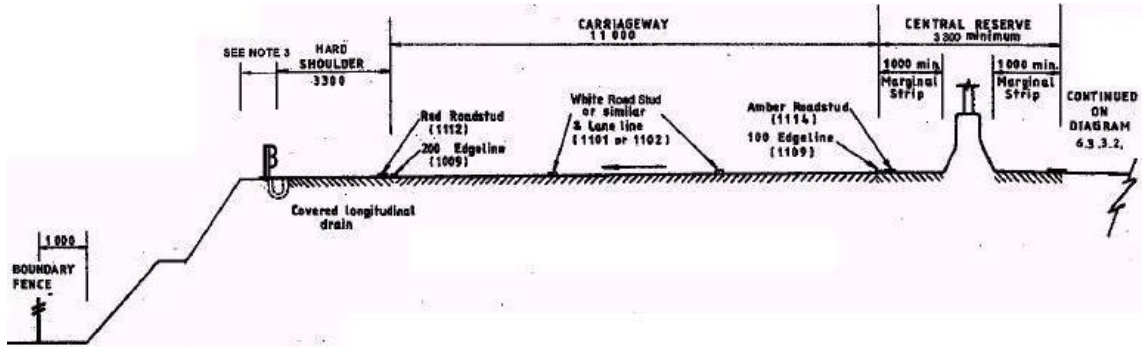

B. WITH KERBS AND GULLIES

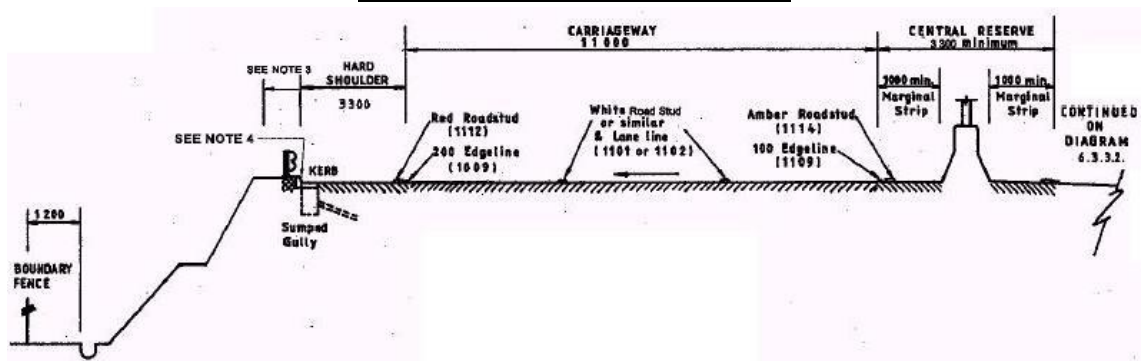

NOT TO SCALE

- NOTES:
1. FOR DETAILS OF ROAD STUDS AND MARKINGS SEE VOLUME 3 OF THIS MANUAL.
 2. ADDITIONAL VERGE WIDTH WILL BE NECESSARY TO ACCOMODATE ROAD SIGNS, AND ROAD FURNITURE, AND MAY BE NECESSARY TO ACHIEVE VISIBILITY REQUIREMENTS AND IF FLAT GROUND IS REQUIRED FOR LANDSCAPING WORKS.
 3. VOLUME 2 SECTION 3.9.3 SHOULD BE REFERRED TO FOR REQUIRED DISTANCE BETWEEN BARRIER FENCE AND SLOPE EDGE WITH RESPECT DIFFERENT BARRIER FENCE TYPE.
 4. ANY KERBS, IF PROVIDED, SHOULD BE POSITIONED ON THE SAME LINE AS THE BARRIER FENCE.
 5. ALL DIMENSIONS ARE IN MILLIMETRES.

**DIAGRAM 6.3.3.2 : RURAL EXPRESSWAY
TYPICAL CROSS SECTION IN CUTTINGS
A. WITH LONGITUDINAL ROAD DRAINAGE**

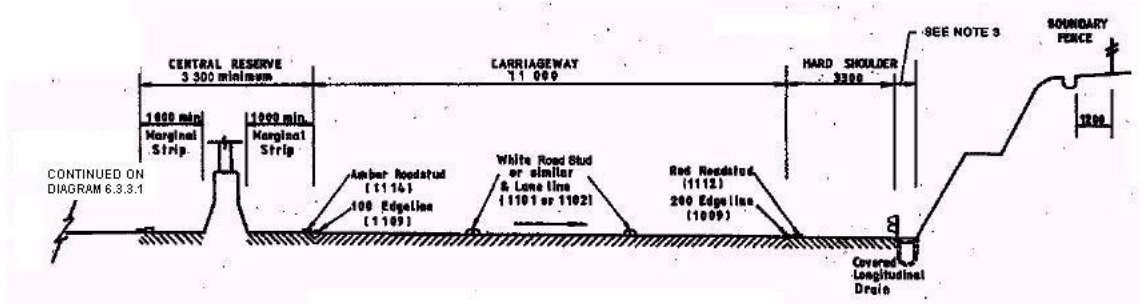

B. WITH KERBS AND GULLIES

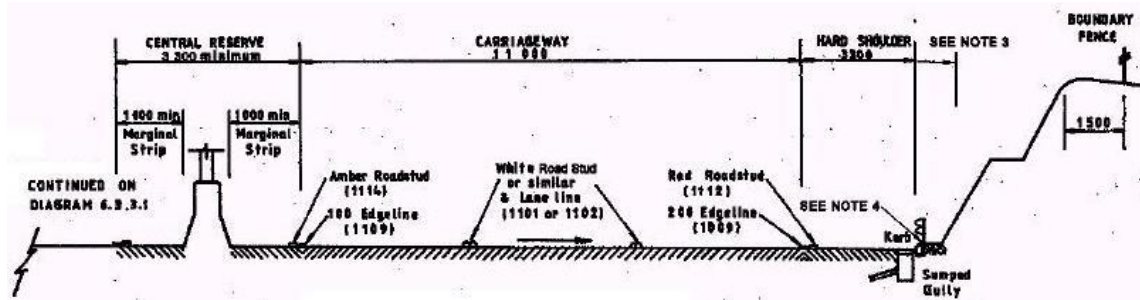

NOT TO SCALE

- NOTES:
1. FOR DETAILS OF ROAD STUDS AND MARKINGS SEE VOLUME 3 OF THIS MANUAL.
 2. ADDITIONAL VERGE WIDTH WILL BE NECESSARY TO ACCOMODATE ROAD SIGNS, AND ROAD FURNITURE, AND MAY BE NECESSARY TO ACHIEVE VISIBILITY REQUIREMENTS AND IF FLAT GROUND IS REQUIRED FOR LANDSCAPING WORKS.
 3. VOLUME 2 SECTION 3.9.3 SHOULD BE REFERRED TO FOR REQUIRED DISTANCE BETWEEN BARRIER FENCE AND SLOPE EDGE WITH RESPECT DIFFERENT BARRIER FENCE TYPE.
 4. ANY KERBS, IF PROVIDED, SHOULD BE POSITIONED ON THE SAME LINE AS THE BARRIER FENCE.
 5. ALL DIMENSIONS ARE IN MILLIMETRES.

**DIAGRAM 6.3.3.3 : RURAL EXPRESSWAY CROSS SECTION
WHERE FULL HARD SHOULDERS CANNOT BE PROVIDED
A. WHERE LOCAL DIFFICULTIES PREVENT A FULL HARD
SHOULDER FROM BEING PROVIDED**

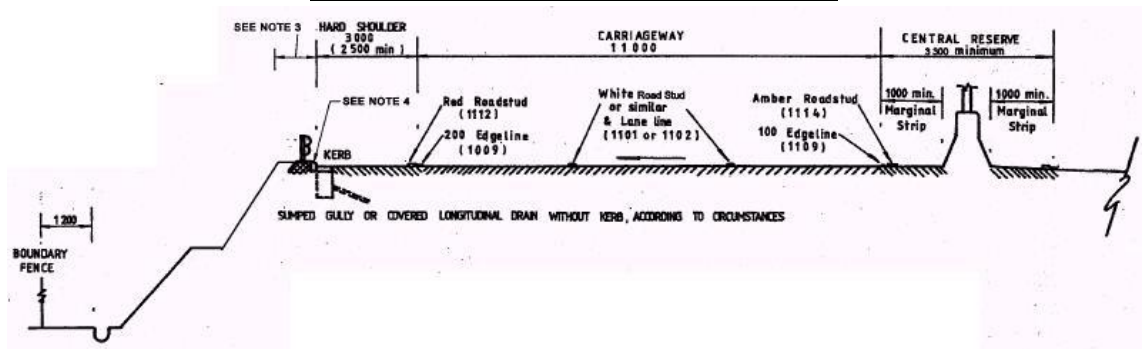

**B. TO BE USED IN EXCEPTIONAL CIRCUMSTANCES ONLY
(NORMALLY ONLY APPLICABLE IN RESPECT OF EXISTING CARRIAGEWAYS)**

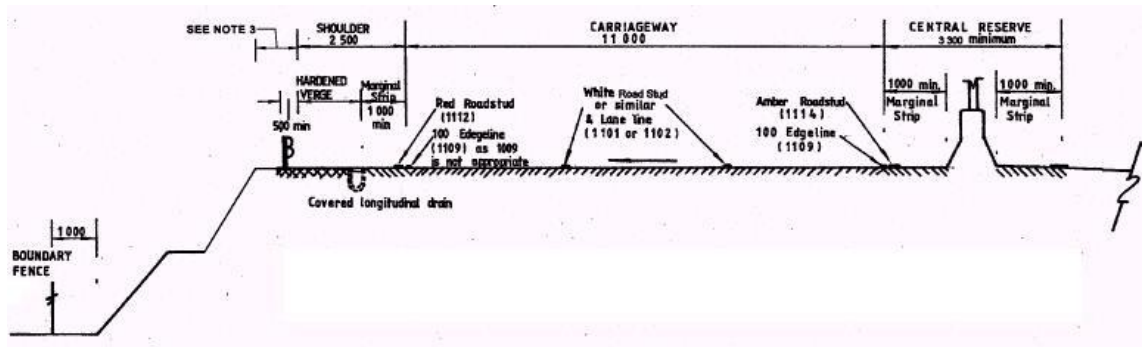

NOT TO SCALE

- NOTES:
1. FOR DETAILS OF ROAD STUDS AND MARKINGS SEE VOLUME 3 OF THIS MANUAL.
 2. ADDITIONAL VERGE WIDTH WILL BE NECESSARY TO ACCOMODATE ROAD SIGNS, AND ROAD FURNITURE, AND MAY BE NECESSARY TO ACHIEVE VISIBILITY REQUIREMENTS AND IF FLAT GROUND IS REQUIRED FOR LANDSCAPING WORKS.
 3. VOLUME 2 SECTION 3.9.3 SHOULD BE REFERRED TO FOR REQUIRED DISTANCE BETWEEN BARRIER FENCE AND SLOPE EDGE WITH RESPECT DIFFERENT BARRIER FENCE TYPE.
 4. ANY KERBS, IF PROVIDED, SHOULD BE POSITIONED ON THE SAME LINE AS THE BARRIER FENCE.
 5. ALL DIMENSIONS ARE IN MILLIMETRES.

**DIAGRAM 6.3.3.4 : URBAN EXPRESSWAY
TYPICAL CROSS SECTION ON EMBANKMENTS
A. WITH LONGITUDINAL ROAD DRAINAGE**

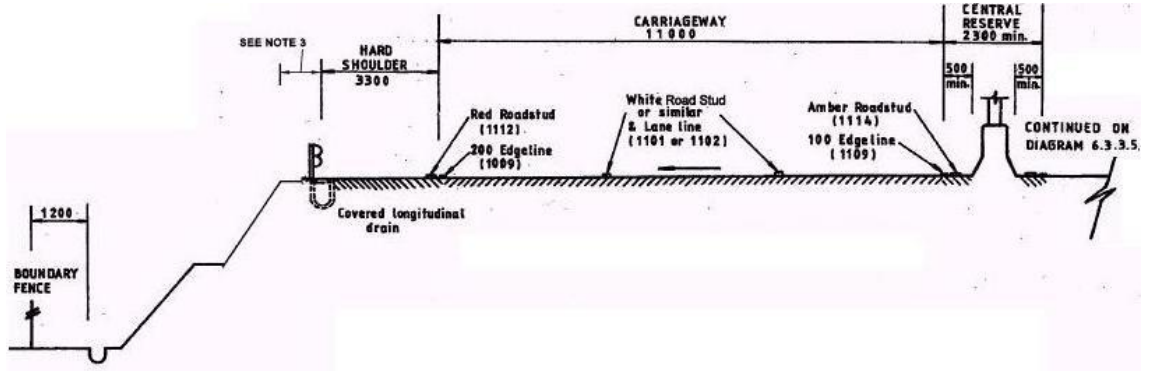

B. WITH KERBS AND GULLIES

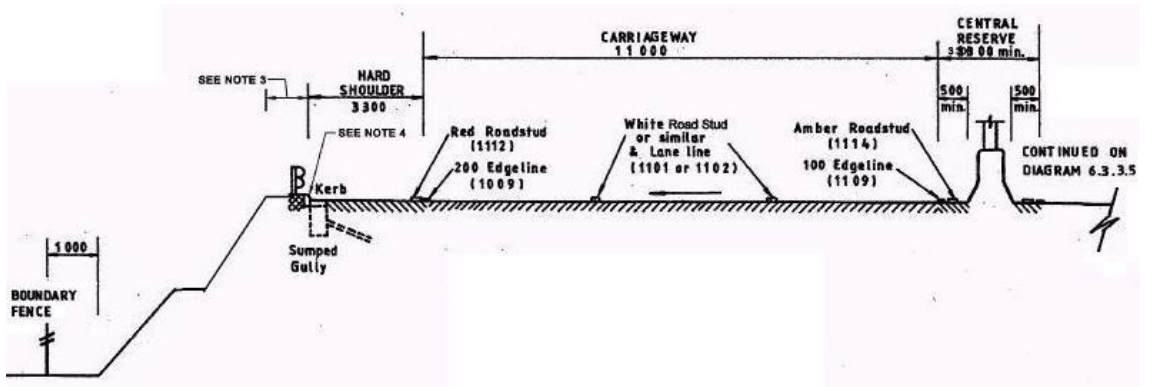

NOT TO SCALE

- NOTES:
1. FOR DETAILS OF ROAD STUDS AND MARKINGS SEE VOLUME 3 OF THIS MANUAL.
 2. ADDITIONAL VERGE WIDTH WILL BE NECESSARY TO ACCOMODATE ROAD SIGNS, AND ROAD FURNITURE, AND MAY BE NECESSARY TO ACHIEVE VISIBILITY REQUIREMENTS AND IF FLAT GROUND IS REQUIRED FOR LANDSCAPING WORKS.
 3. VOLUME 2 SECTION 3.9.3 SHOULD BE REFERRED TO FOR REQUIRED DISTANCE BETWEEN BARRIER FENCE AND SLOPE EDGE WITH RESPECT DIFFERENT BARRIER FENCE TYPE.
 4. ANY KERBS, IF PROVIDED, SHOULD BE POSITIONED ON THE SAME LINE AS THE BARRIER FENCE.
 5. ALL DIMENSIONS ARE IN MILLIMETRES.

**DIAGRAM 6.3.3.5 : URBAN EXPRESSWAY
TYPICAL CROSS SECTION IN CUTTINGS
A. WITH LONGITUDINAL ROAD DRAINAGE**

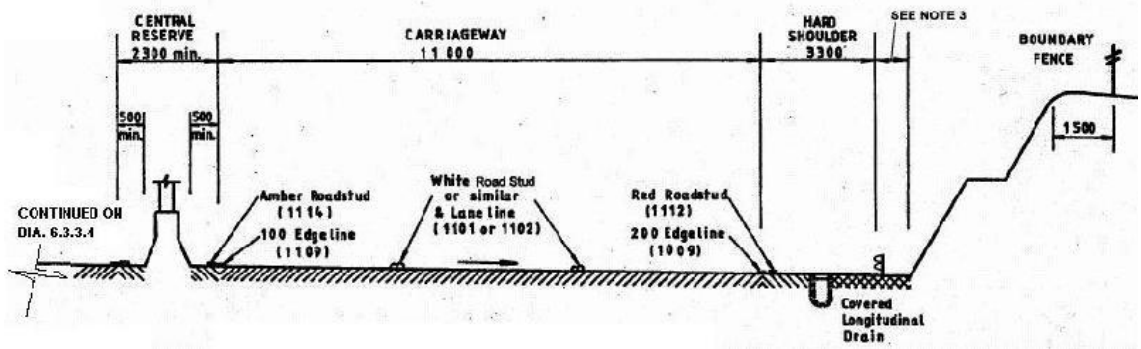

B. WITH KERBS AND GULLIES

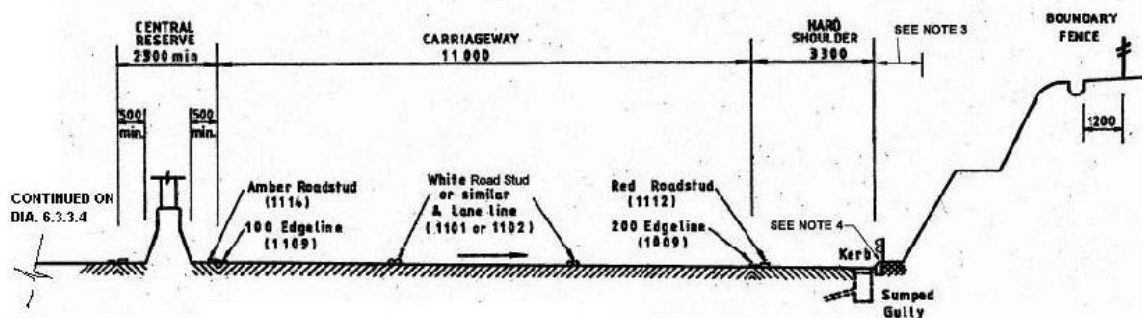

NOT TO SCALE

- NOTES:
1. FOR DETAILS OF ROAD STUDS AND MARKINGS SEE VOLUME 3 OF THIS MANUAL.
 2. ADDITIONAL VERGE WIDTH WILL BE NECESSARY TO ACCOMODATE ROAD SIGNS, AND ROAD FURNITURE, AND MAY BE NECESSARY TO ACHIEVE VISIBILITY REQUIREMENTS AND IF FLAT GROUND IS REQUIRED FOR LANDSCAPING WORKS.
 3. VOLUME 2 SECTION 3.9.3 SHOULD BE REFERRED TO FOR REQUIRED DISTANCE BETWEEN BARRIER FENCE AND SLOPE EDGE WITH RESPECT DIFFERENT BARRIER FENCE TYPE.
 4. ANY KERBS, IF PROVIDED, SHOULD BE POSITIONED ON THE SAME LINE AS THE BARRIER FENCE.
 5. ALL DIMENSIONS ARE IN MILLIMETRES.

DIAGRAM 6.3.3.6 : ELEVATED EXPRESSWAY URBAN OR RURAL SITUATION

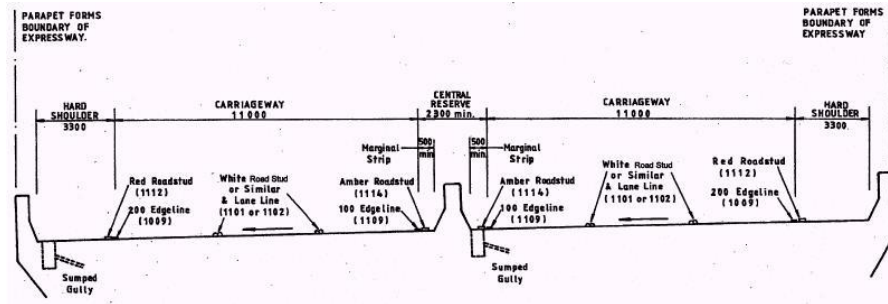

TYPICAL CROSS SECTION
NOT TO SCALE

- NOTES:
1. FOR DETAILS OF ROAD STUDS AND MARKINGS SEE VOLUME 3 OF THIS MANUAL.
 2. ADDITIONAL VERGE WIDTH WILL BE NECESSARY TO ACCOMODATE ROAD SIGNS, AND ROAD FURNITURE, AND MAY BE NECESSARY TO ACHIEVE VISIBILITY REQUIREMENTS AND IF FLAT GROUND IS REQUIRED FOR LANDSCAPING WORKS.
 3. VOLUME 2 SECTION 3.9.3 SHOULD BE REFERRED TO FOR REQUIRED DISTANCE BETWEEN BARRIER FENCE AND SLOPE EDGE WITH RESPECT DIFFERENT BARRIER FENCE TYPE.
 4. ANY KERBS, IF PROVIDED, SHOULD BE POSITIONED ON THE SAME LINE AS THE BARRIER FENCE.
 5. ALL DIMENSIONS ARE IN MILLIMETRES.

DIAGRAM 6.3.3.7 : EXPRESSWAY IN DEPRESSED ROADWAY WHERE THERE ARE RETAINING WALLS OR ABUTMENTS OR SIMILAR URBAN OR RURAL SITUATION

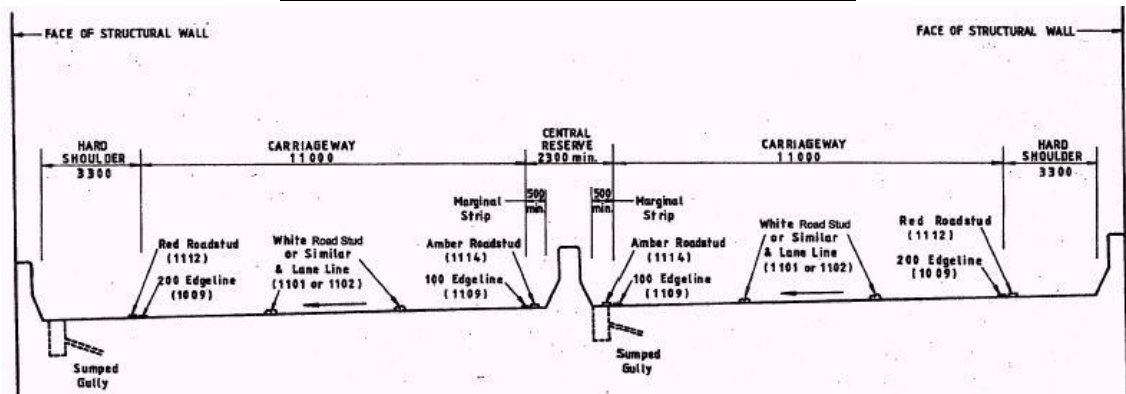

TYPICAL CROSS SECTION
NOT TO SCALE

- NOTES:
1. FOR DETAILS OF ROAD STUDS AND MARKINGS SEE VOLUME 3.
 2. ROADWAY DRAINAGE IN DEPRESSED ROADWAY SECTIONS WILL NORMALLY BE BY SUMPED GULLIES LOCATED AT THE BACK OF THE HARD SHOULDER.
 3. WIDENING MAY BE NECESSARY TO ACHIEVE VISIBILITY REQUIREMENTS AND TO ACCOMODATE ROAD SIGNS AND STREET FURNITURE.
 4. ALL DIMENSIONS ARE IN MILLIMETRES.

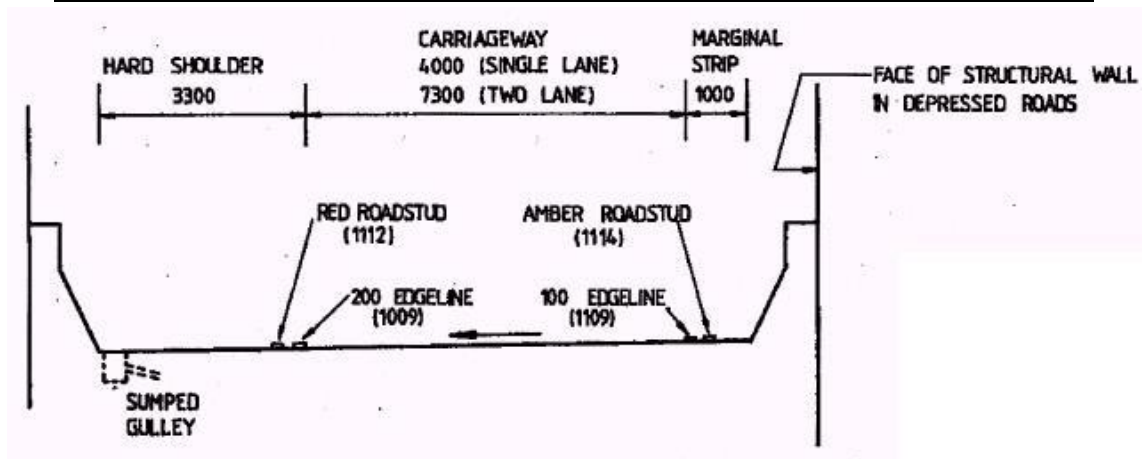
DIAGRAM 6.3.3.8 : EXPRESSWAY LINK ROAD DEPRESSED OR ELEVATED**TYPICAL CROSS SECTION**

NOT TO SCALE

- NOTES:
1. FOR DETAILS OF ROAD STUDS AND MARKINGS SEE VOLUME 3.
 2. DRAINAGE ON DEPRESSED SECTIONS WILL NORMALLY BE BY SUMPED GULLIES LOCATED AT THE BACK OF THE HARD SHOULDER.
 3. THE MARGINAL STRIP MAY BE REDUCED TO NOT LESS THAN 500mm FOR 2-LANE URBAN EXPRESSWAY LINK ROADS WHERE LOCAL DIFFICULTIES EXIST.
 4. WIDENING MAY BE NECESSARY TO ACCOMODATE ROAD SIGNS AND STREET FURNITURE AND TO ACHIEVE VISIBILITY REQUIREMENTS.
 5. ALL DIMENSIONS ARE IN MILLIMETRES.

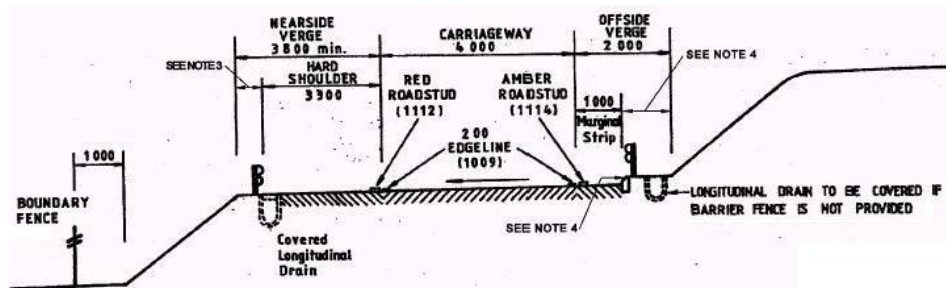
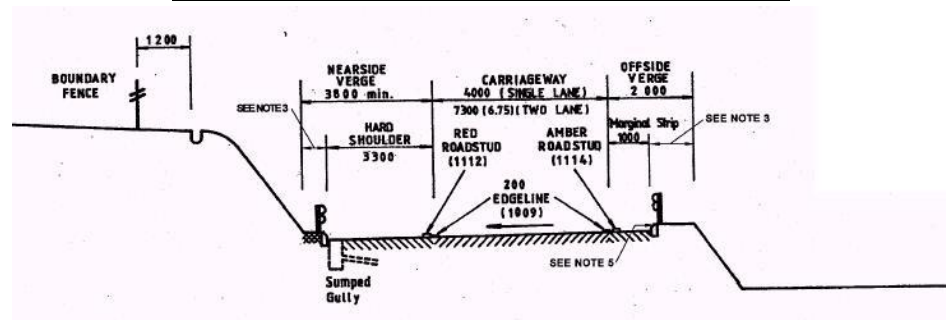
DIAGRAM 6.3.3.9 : EXPRESSWAY SLIP ROADS**TYPICAL CROSS SECTIONS****A. ON EMBANKMENT WITH LONGITUDINAL ROAD DRAINAGE****B. IN CUTTING WITH KERBS AND GULLIES**

NOT TO SCALE

- NOTES:
- FOR DETAILS OF ROAD STUDS AND MARKINGS SEE VOLUME 3 OF THIS MANUAL.
 - ADDITIONAL VERGE WIDTH WILL BE NECESSARY TO ACCOMODATE ROAD SIGNS, AND ROAD FURNITURE, AND MAY BE NECESSARY TO ACHIEVE VISIBILITY REQUIREMENTS AND IF FLAT GROUND IS REQUIRED FOR LANDSCAPING WORKS.
 - VOLUME 2 SECTION 3.9.3 SHOULD BE REFERRED TO FOR THE NECESSITY OF BARRIER FENCE AT SLOPE TOE.
 - ANY KERBS, IF PROVIDED, SHOULD BE POSITIONED ON THE SAME LINE AS THE BARRIER FENCE.
 - ALL DIMENSIONS ARE IN MILLIMETRES.

DIAGRAM 6.3.3.10 : EXPRESSWAY SLIP ROADS
WHERE FULL WIDTH HARD SHOULDERS CANNOT BE PROVIDED
(A) WHERE LOCAL DIFFICULTIES PREVENT A FULL HARD SHOULDER FROM BEING PROVIDED

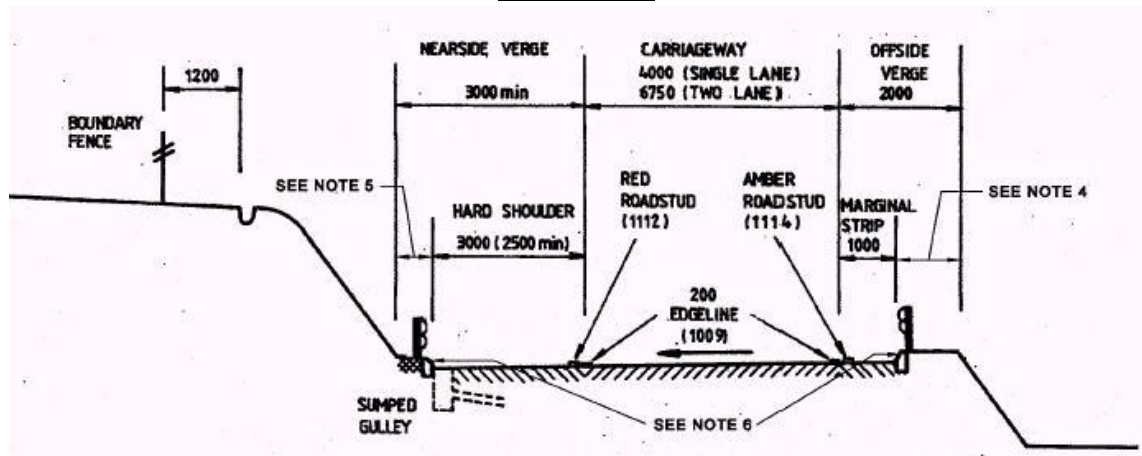

(B) TO BE USED IN EXCEPTIONAL CIRCUMSTANCES ONLY

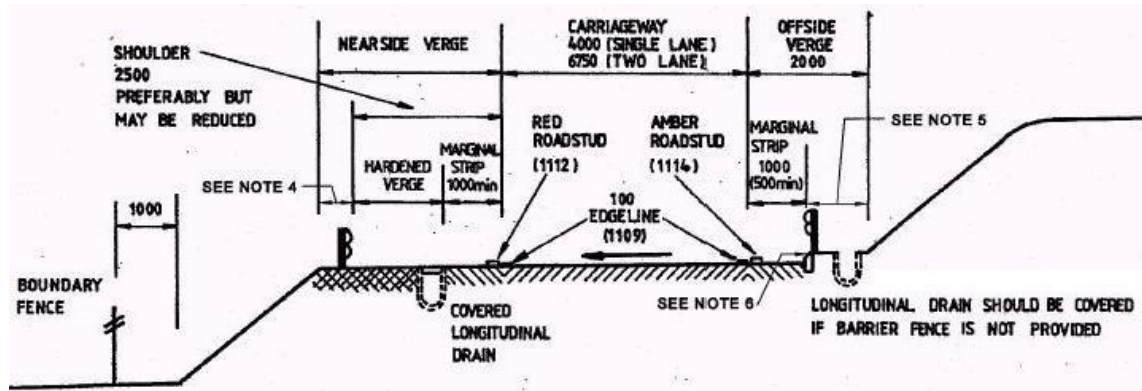

NOT TO SCALE

- NOTES:
1. FOR DETAILS OF ROAD STUDS AND MARKINGS SEE VOLUME 3 OF THIS MANUAL.
 2. ADDITIONAL VERGE WIDTH WILL BE NECESSARY TO ACCOMMODATE ROAD SIGNS, AND STREET FURNITURE, AND MAY BE NECESSARY TO ACHIEVE VISIBILITY REQUIREMENTS.
 3. ADDITIONAL VERGE WIDENING FOR LANDSCAPING IS NOT ACCEPTABLE IF FULL WIDTH HARD SHOULDERS CANNOT BE PROVIDED.
 4. VOLUME 2 SECTION 3.9.3 SHOULD BE REFERRED TO FOR REQUIRED DISTANCE BETWEEN BARRIER FENCE AND SLOPE EDGE WITH RESPECT DIFFERENT BARRIER FENCE TYPE.
 5. VOLUME 2 SECTION 3.9.3 SHOULD BE REFERRED TO FOR THE NECESSITY OF BARRIER FENCE AT SLOPE TOE.
 6. ANY KERBS, IF PROVIDED, SHOULD BE POSITIONED ON THE SAME LINE AS THE BARRIER FENCE.
 7. ALL DIMENSIONS ARE IN MILLIMETRES.

- 6.3.3.8 It is most desirable that the standard 3300mm hard shoulder width is maintained throughout the Expressway Network. However whenever this is not possible, this may be reduced to 3000mm, as shown in Diagrams 6.3.3.3 and 6.3.3.10 to meet local difficulties for both rural and urban conditions. Any reduction below 3000mm, and never to less than 2500mm, on the main line, including any link roads, will only be permitted in extenuating circumstances and a full justification will be required as to why such reduction is necessary. Cost alone should not be regarded as sufficient justification in this respect.
- 6.3.3.9 In 'B' in Diagram 6.3.3.10, along slip roads the provision of a marginal strip only may be acceptable, generally in urban conditions, where exceptional situations prevail which makes the provision of a shoulder or full hard shoulder highly impractical. In such circumstances a full justification of why only a nearside marginal strip can be provided must be given.
- 6.3.3.10 Where, as in Diagrams 6.3.3.3 and 6.3.3.10, the shoulder consists of a hardened verge, this verge should only be grassed, preferably with height not more than 200mm, but in any case not taller than 300mm. Ground cover plants with sprawling habit such as 'Wedelia Trilobata' must not be used at hardened verges.
- 6.3.3.11 The cross sections shown are for typical situations and extra width may be necessary where for instance, the carriageway crossfall reverses and additional drainage channels are thereby required. Also the central reserve widths are minimal and if for example traffic signs, other than repeater signs, are required to be erected on the central reserve, which will need to be of the 1200mm size, to obtain the normal clearances of 1000mm for this type of road a reserve width of 3200mm will be required. For isolated signs in extenuating circumstances this may be reduced, but the clearance between the sign and the edge of the carriageway should never be less than 600mm, which implies a central reserve width of at least 2400mm.
- 6.3.3.12 Additionally as mentioned in paragraph 6.3.3.2 the cross sections do not allow for the provision of road side signs; any visibility splays which might be required; and landscaping. For these latter elements additional land will be required. If lighting columns are located on the nearside of the road due to whatever reason, additional land will be required and a barrier fence should be provided as a protection for the columns. This is particularly relevant to slip roads and link roads, where often road lighting columns will need to be located on the nearside.
- 6.3.3.13 Where only a marginal strip is provided along a slip road the taper in respect of the widening to or from the hard shoulder provided along the main route should be in accordance with Diagram 6.3.3.11.

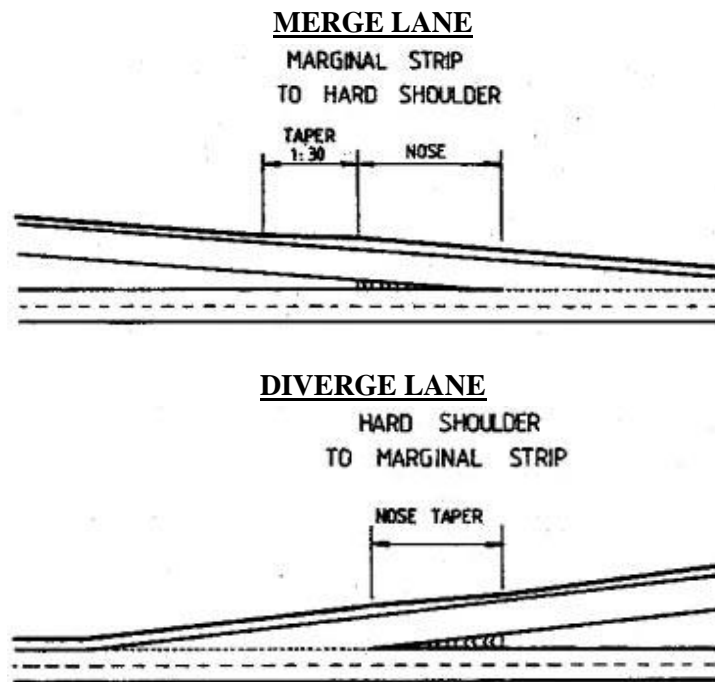
DIAGRAM 6.3.3.11 : MARGINAL STRIP TO HARD SHOULDER TAPERS**6.3.4 Drainage Considerations**

- 6.3.4.1 Where longitudinal road drainage of the slotted channel type is to be used, and this is particularly preferable in flat terrain, the covers of the slotted channels should be laid at the rear of the hard shoulder.
- 6.3.4.2 Where drainage is required the kerb should be laid at the rear of the hard shoulder, with gullies located adjacent to the kerb.
- 6.3.4.3 Wherever manhole covers are provided, they should be located in the hard shoulder or preferably in the verge beyond this. This implies that the road pavement drainage carrier drains should also be located beneath the hard shoulder or verge but where this is not possible the manhole access shaft and hence the manhole cover should be located within the hard shoulder or as near to it as possible. Heavy duty manhole covers should always be used, even where they are located within the verge or hard shoulder.
- 6.3.4.4 Any longitudinal drains placed at or within 3m of the rear of the shoulder should be covered, where for any reasons this is not possible or not desirable from a maintenance point of view, a barrier fence must be erected in front of the drain.

6.3.5 Boundary Fences

- 6.3.5.1 Boundary fences should be located to define the extent of the Expressway and to prevent pedestrians from inadvertently walking onto the Expressway. They will normally be sited at the top of cuttings or at the bottom of embankments or at the back of the verge where there are no earthworks.
- 6.3.5.2 The dimension to the fence from the top or bottom of earthworks should take account of whether or not a drainage channel is present.
- 6.3.5.3 The dimensions shown on diagrams 6.3.3.1 to 6.3.3.10 give a guide to the normal positions for boundary fences but these may need to be varied according to the site conditions.

- 6.3.5.4 It is stressed that boundary fences must not be used to deter illegal parking on verges forming part of the Expressway by locating the fence in the immediate vicinity of the hard shoulder. Apart from the fact that in this location they will not properly indicate the boundary of the Expressway, they could also by being so close to the carriageway, constitute a hazard. It also makes difficult access to the verge for maintenance purposes.
- 6.3.5.5 In some situations the boundary of the Expressway may be extremely close to the carriageway and a boundary fence may be required to separate for example an adjacent cycle track from the Expressway. In these cases the boundary fence should be erected as far away from the edge of the hard shoulder as possible, providing at least 1000mm clearance between the fence and the hard shoulder. It may also be necessary to erect a barrier fence immediately in front of the boundary fence to lessen the hazardous effect of the latter.
- 6.3.5.6 Details of boundary fences should accord with the Highways Department's current standard drawings for such fences.
- 6.3.6 Junctions**
- 6.3.6.1 Junctions on Expressways will always be grade separated. Detailed requirements for the layout of grade separated junctions are given in Section 4.6 of Chapter 4 of this Volume.
- 6.3.6.2 Junctions on Expressways should preferably be spaced at about 5km intervals but where circumstances require a closer spacing, this should not be reduced to below 2km.
- 6.3.6.3 New junctions giving access onto an existing Expressway should only be permitted to allow an extension of the Expressway system or to link a primary distributor road to an Expressway. Junctions or accesses, even when provided with full acceleration and deceleration lanes, just to serve adjacent developments, however large, should not be permitted. Such developments should be connected via the minor road network to the Expressway by means of an existing junction.
- 6.3.6.4 Where it is essential to adopt a close spacing for junctions, particular attention must be paid to the weaving length between the end of the merge taper and the start of the diverge taper, as detailed in Section 4.6.10 of Chapter 4 this Volume.
- 6.3.6.5 Junctions should be designed with the minor road crossing over the major road so that entry slip road gradients are down towards the major road of the Expressway and exit slip roads are up away from the major road of the Expressway. This aids the acceleration of vehicles entering the Expressway and likewise assists their deceleration as they leave.
- 6.3.6.6 Where large traffic flows with nearly full capacity are joining the mainline in an interchange or junction, turbulence can occur with short headways and sudden braking. A parallel merge lane should be provided to increase local capacity.
- 6.3.6.7 If the joining flows are greater than one lane capacity then an additional lane should normally be added to the mainline as a lane gain.
- 6.3.6.8 Any queuing back to rejoin the local network to impede the mainline traffic should be prevented by providing an auxiliary lane.

- 6.3.6.9 Whilst it may be possible to justify lane drops within grade separated junctions on capacity grounds, the number of lanes through the junction should not be reduced to less than three and lane drops should not differ by more than one. Furthermore, the Expressway Legislation requires drivers 'to keep to the left unless overtaking' and thus lane drops will necessitate additional signing and marking. Advice on this is included in Chapters 2 and 5 respectively of Volume 3.
- 6.3.6.10 Lane drops do complicate enforcement procedures particularly with regard to the general prohibition for medium and heavy goods vehicles and buses using the fast lane of a three lane carriageway, as at the point the lane drop starts the carriageway ceases to be regarded as three lanes. Additionally lane drops particularly can cause difficulty to drivers on the nearside lane who either have to make a sudden movement to remain on the main line, or to follow the slip road. Both situations can be the cause of accidents occurring. Therefore when considering the use of lane drops along Expressways account must be taken: of the necessity to use gantry signs, and not road side signs; whether the use of a "lane drop" will create unnecessary difficulties in respect of any future maintenance requirements; and that all regulations in respect of overtaking, lane prohibitions, and keeping to the left can be adequately enforced.
- 6.3.6.11 Junction designs requiring offside slip roads where by the fast lane in effect becomes the slow lane for vehicles leaving the Expressway should be avoided. Apart from the obvious dangers such designs can cause because of the necessary weaving involving vehicle travelling at high speed, it also complicates enforcement in respect of vehicles keeping to the left and heavier vehicles not being permitted to use the fast lane of a three or more lane carriageway.
- 6.3.6.12 At an intersection of two Expressways where a carriageway diverges to form two carriageways of equal status, it will be necessary for vehicles to weave across lanes and the notion of having a fast and slow lane in the vicinity of these junctions will generally not apply. However it is essential that a sufficient weaving length is provided for the manoeuvres to be carried out safely, and that adequate directional signs in the form of gantries are provided.
- 6.3.6.13 Access to Service Areas or Maintenance Operation Centres should be either off the Expressway by purpose designed grade separated facilities or from the minor road network adjacent to a grade separated junction, and further advice on this is contained in Section 6.7.
- 6.3.6.14 Although the general principles in respect of the design of merging and diverging lanes given in Sections 4.6.8 and 4.6.9 respectively of Chapter 4 of this Volume will apply to Expressways, the various dimensions regarding merging and diverging lane lengths will not, as in Sections 4.6.8 and 4.6.9 the dimensions are based on a main line design speed of 100 km/h or less.
- 6.3.6.15 Diagrams 6.3.6.1 to 6.3.6.7 show the appropriate dimensions and entry and nose taper angles for Expressway merging and diverging lanes for main line design speeds appropriate to 100 km/h or less.

DIAGRAM 6.3.6.1 : EXPRESSWAY MERGING LANES (DESIGN SPEED 100 km/h OR LESS)

DIRECT ENTRY MERGING LANE (TYPES 1 + 4)

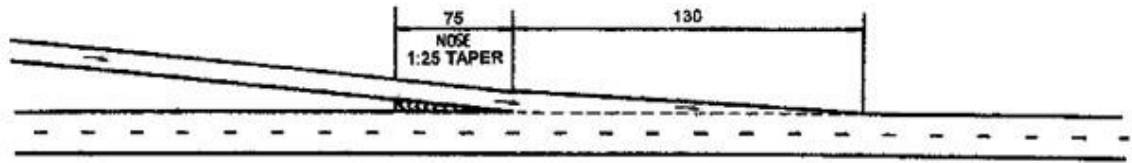

PARALLEL MERGING LANE (TYPES 1 + 4)

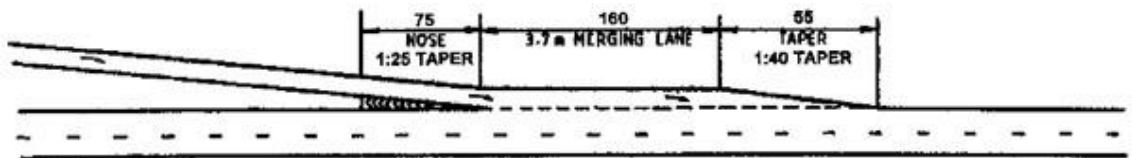

- NOTES:
- (i) TYPE 1 SINGLE LANE LINK TO TWO LANE MAIN LINE
 - (ii) TYPE 4 SINGLE LANE LINK TO THREE LANE MAIN LINE
 - (iii) SEE ALSO SECTION 4.6.8 OF CHAPTER 4

DIAGRAM 6.3.6.2 : EXPRESSWAY MERGING LANES (DESIGN SPEED 100 km/h OR LESS)

SHADOW ISLAND MERGING LANE (TYPE 2 + 5)

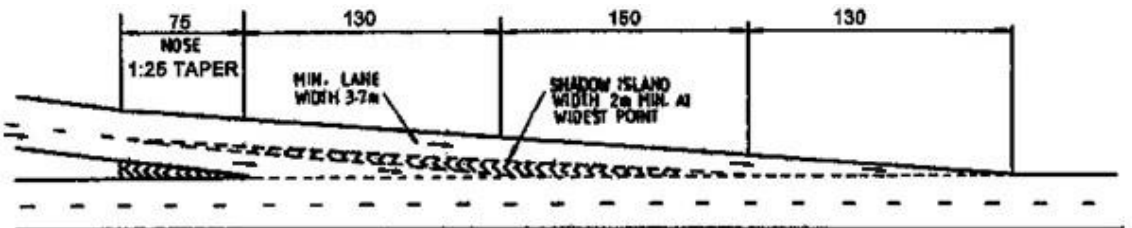

- NOTES:
- (i) TYPE 2 TWO LANE LINK TO TWO LANE MAIN LINE
 - (ii) TYPE 5 TWO LANE LINK TO THREE LANE MAIN LINE
 - (iii) SEE ALSO SECTION 4.6.8 OF CHAPTER 4
 - (iv) ONLY USED WHERE DESIGN FLOWS ON MAINLINE ARE LIGHT AND THERE ARE 3 LANES OR MORE ON MAINLINE

DIAGRAM 6.3.6.3 : EXPRESSWAY MERGING LANES (DESIGN SPEED 100 km/h OR LESS)

SHADOW ISLAND MERGING LANE (TYPE 3 + 6)

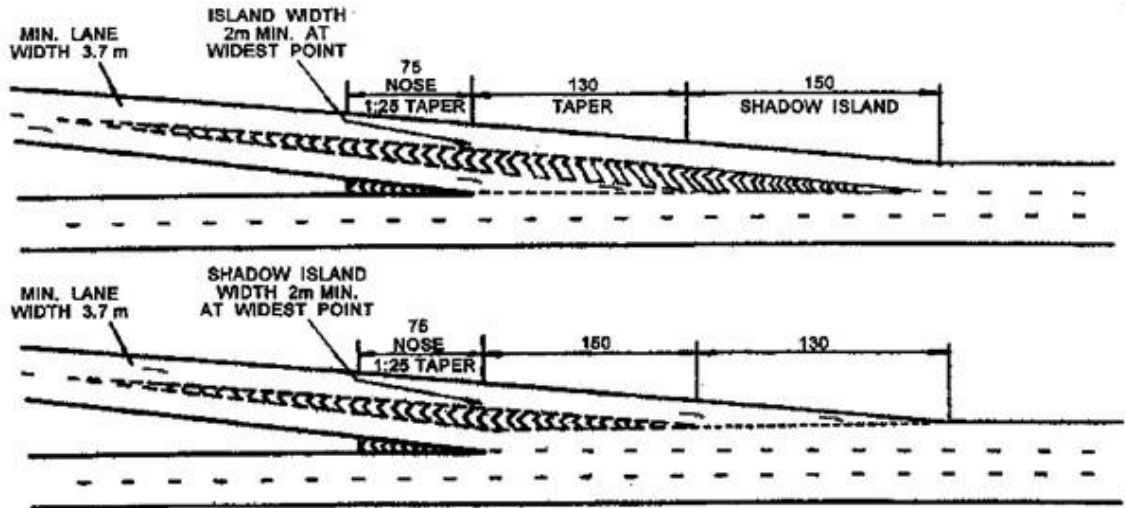

- NOTES:
- (i) TYPE 3 TWO LANE LINK - MAIN LINE TWO INCREASING TO THREE
 - (ii) TYPE 6 TWO LANE LINK - MAIN LINE THREE INCREASING TO FOUR
 - (iii) SEE ALSO SECTION 4.6.8 OF CHAPTER 4

DIAGRAM 6.3.6.4 : EXPRESSWAY MERGING LANES (DESIGN SPEED 100 km/h OR LESS)

ADDITIONAL LANE - NO IMMEDIATE MERGING (TYPES 7 + 9)

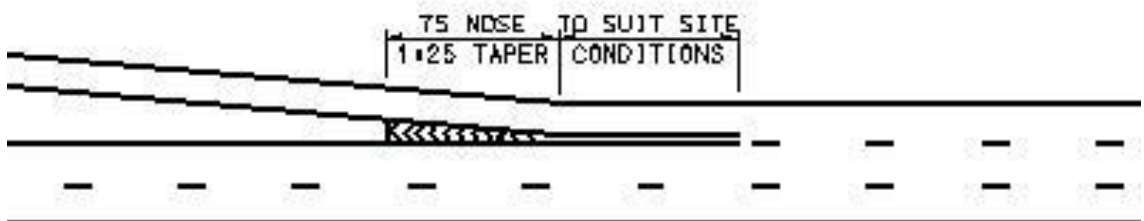

- NOTES:
- (i) TYPE 7 SINGLE LANE LINK - MAIN LINE TWO INCREASING TO THREE
 - (ii) TYPE 9 SINGLE LANE LINK - MAIN LINE THREE INCREASING TO FOUR
 - (iii) TYPE 8 TWO LANE LINK - MAIN LINE TWO INCREASING TO FOUR
 - (iv) SEE ALSO SECTION 4.6.8 OF CHAPTER 4

DIAGRAM 6.3.6.5 : EXPRESSWAY DIVERGING LANES (DESIGN SPEED 100 km/h OR LESS)

DIRECT DIVERGING LANE (TYPES 1 + 3)

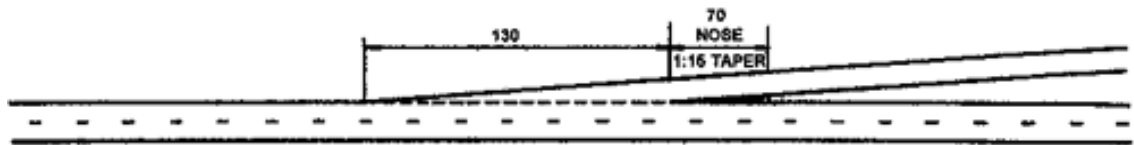

PARALLEL DIVERGING LANE (TYPES 1 + 3)

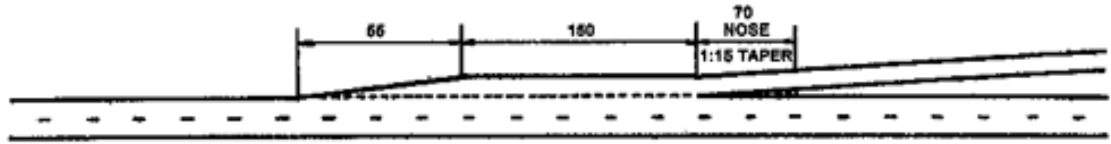

- NOTES:
- (i) TYPE 1 ONE LANE LINK FROM TWO LANE MAIN LINE
 - (ii) TYPE 3 ONE LANE LINK FROM THREE LANE MAIN LINE
 - (iii) SEE ALSO SECTION 4.6.9 OF CHAPTER 4

DIAGRAM 6.3.6.6 : EXPRESSWAY DIVERGING LANES (DESIGN SPEED 100 km/h OR LESS)

DIRECT DIVERGING LANES (TYPES 2 + 5)

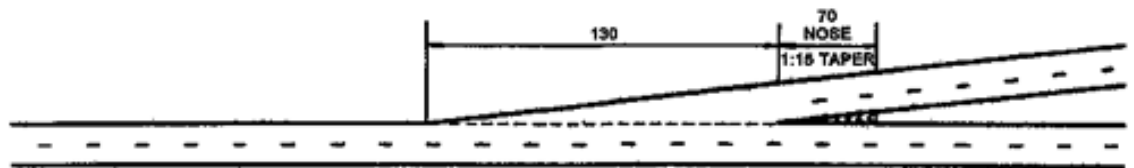

PARALLEL DIVERGING LANES (TYPES 2 + 5)

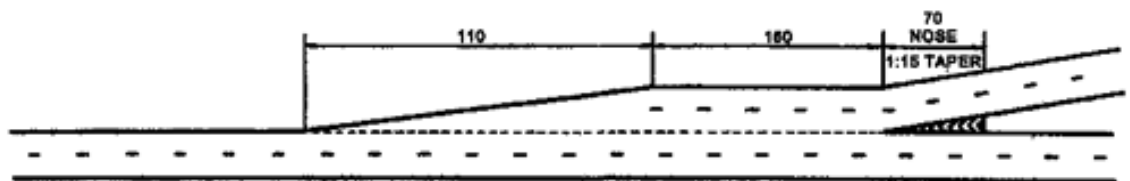

- NOTES:
- (i) TYPE 2 TWO LANE LINK FROM TWO LANE MAIN LINE
 - (ii) TYPE 5 TWO LANE LINK FROM THREE LANE MAIN LINE
 - (iii) SEE ALSO SECTION 4.6.9 OF CHAPTER 4

DIAGRAM 6.3.6.7 : EXPRESSWAY DIVERGING LANES (DESIGN SPEED 100 km/h OR LESS)

DIRECT DIVERGING LANES (TYPES 4 + 6)

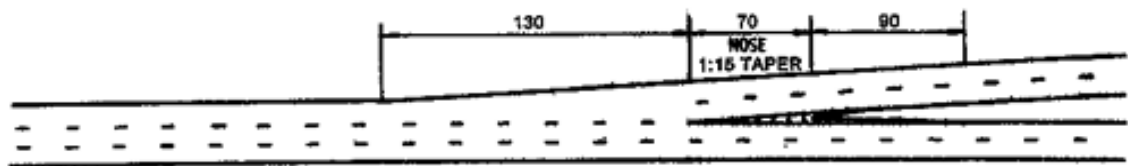

PARALLEL DIVERGING LANES (TYPES 4 + 6)

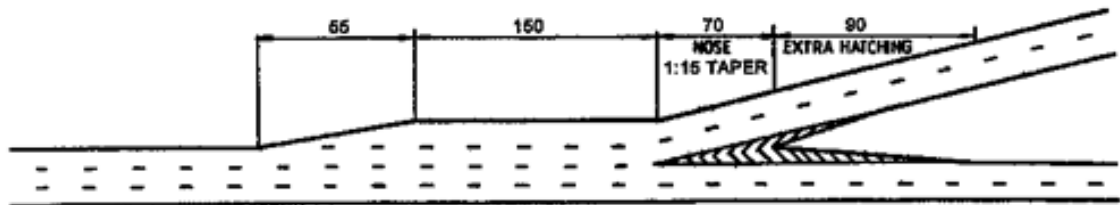

- NOTES:
- (i) TYPE 4 TWO LANE LINK - MAIN LINE THREE LANES DECREASING TO TWO LANES
 - (ii) TYPE 6 TWO LANE LINK - MAIN LINE FOUR LANES DECREASING TO THREE LANES
 - (iii) SEE ALSO SECTION 4.6.9 OF CHAPTER 4

6.3.7 Access

- 6.3.7.1 Access to and from any Expressway should be provided only at the regularly spaced grade separated junctions, as access at any other location should be prohibited. Direct access off slip roads, which must be regarded as an integral part of an Expressway, should not for any reason be permitted.
- 6.3.7.2 Intermediate access, for whatever purpose, must not be allowed, and the boundary fence must be regularly maintained to ensure that no illegal accesses are created.
- 6.3.7.3 Before a road can be designated as an Expressway any existing unauthorised accesses must be effectively curtailed and physically closed up. The same applies to any authorised accesses, such as, entrances/exits from service roads, bus stops, or similar, which must be removed and/or relocated away from the Expressway before the road may be considered as an Expressway.
- 6.3.7.4 Pedestrians and animals are prohibited from using any Expressway. However following a vehicle breakdown, a driver is permitted to walk along the verge or hard shoulder to reach the nearest emergency telephone and thus the verge should be designed with this in mind, to discourage the driver from walking on the carriageway.

6.4 Permanent Signs and Road Markings

6.4.1 General

- 6.4.1.1 Detailed information on the size, location and mounting of permanent traffic signs and directional signs is given in Chapters 2 and 3 of Volume 3 respectively of this manual.
- 6.4.1.2 The start and end of an Expressway which will generally mean all entry and exit points at the junction of the slip roads with the minor road network, must be signed by the appropriate Expressway sign as shown in Diagram 6.4.1.1 to indicate that the legislation pertaining to Expressways applies.
- 6.4.1.3 The Expressway signs should be located on the nearside verge in the case of single lane slip roads, and opposite each other on both sides of the carriageway on two-lane slip roads, as shown in Diagram 6.4.1.2.
- 6.4.1.4 A "NO ENTRY" sign, traffic sign 115, should be mounted on the reverse side of each "END OF AN EXPRESSWAY" sign, traffic sign 354, to make it clear that traffic must not enter the exit slip road.
- 6.4.1.5 Expressway confirmation signs should be placed approximately 100m beyond the end of each acceleration taper. The signs, which must also show the appropriate route number shield, should always be located singly at the back of the nearside verge, as shown in Diagram 6.4.1.2. Further information on these confirmatory signs is given in Chapter 3 of Volume 3.
- 6.4.1.6 If speed limit of slip road is lowered within 400m from the tip of chevron marking, 10 No. of transverse yellow bar markings of 600mm wide with 5m gap should be provided at the diverge lane of roads with speed limits of 70 km/h or above as shown in Diagram 6.4.1.3. Provision of these bar markings should be in accordance to the following:
- (i) For direct diverge, the first bar marking should be provided where the lane width is at least 2.5m as shown in Diagram 6.4.1.3(i); and for short diverging lane, bar marking should be provided in accordance with Diagram 6.4.1.3(ii);
 - (ii) Traffic sign TS 737 "REDUCE SPEED NOW" should be provided at the start of the bar marking.
 - (iii) As for other slip roads where the lowering of speed limit is beyond 400m from tip of chevron marking, transverse bar marking is not required, as it is similar to the situation of a main carriageway, and traffic signs 570 and 769 should be adequate as shown in Diagram 6.4.1.3(v).
- 6.4.1.7 All regulatory and warning traffic signs used along an Expressway must be reflectorised and, other than for repeater signs, should be of the equivalent 1200mm size.
- 6.4.1.8 Warning signs used along Expressway should be located assuming the highest speed limit, in accordance with Table 2.2.2.1 of Chapter 2, Volume 3, that is 250m - 300m in advance of the hazard and having a minimum clear visibility of 100m. Any supplementary plates used with these signs should be the largest plate size available, again, in accordance with Table 2.2.2.1 of Chapter 2, Volume 3, assuming the highest approach speed.

6.4.1.9

On Expressways, because of the need to maintain an unobstructed shoulder along the nearside of each carriageway, it is essential that careful consideration is given to the location of permanent road signs at the design stage. Whilst the smaller repeater signs used for speed limits can usually be accommodated behind the barrier fence or at points where extra space is available, the larger signs such as 'direction signs', 'advanced direction signs', main speed limit signs, and the start/end of Expressway signs, will require specific space to be made available. Guidance on the location of permanent road signs is given in Diagrams 6.4.1.4 to 6.4.1.6 inclusive, and further advice can be found in Chapters 2 and 3 of Volume 3.

DIAGRAM 6.4.1.1 : EXPRESSWAY SIGNS
START AND CONTINUATION OF AN EXPRESSWAY
TS 353

THIS SIGN INDICATES THE START & CONTINUATION OF THE AREA WHERE THE PROHIBITIONS AND RESTRICTIONS IMPOSED BY THE EXPRESSWAY LEGISLATION APPLY.

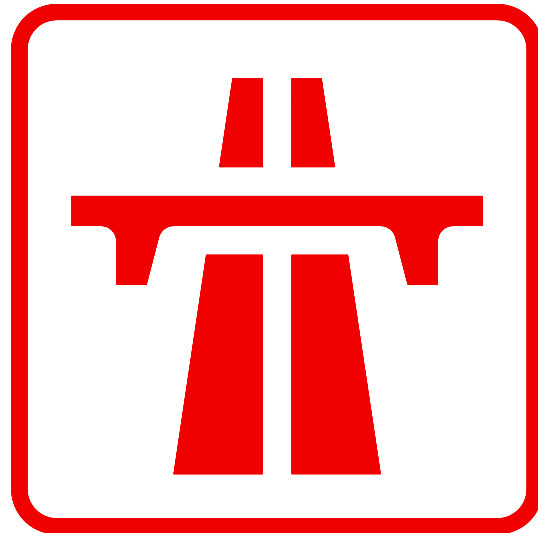

END OF AN EXPRESSWAY
TS 354

THIS SIGN INDICATES THE END OF THE AREA WHERE THE PROHIBITIONS AND RESTRICTIONS IMPOSED BY THE EXPRESSWAY LEGISLATION APPLY.



DIAGRAM 6.4.1.2 : LOCATION OF EXPRESSWAY SIGNS

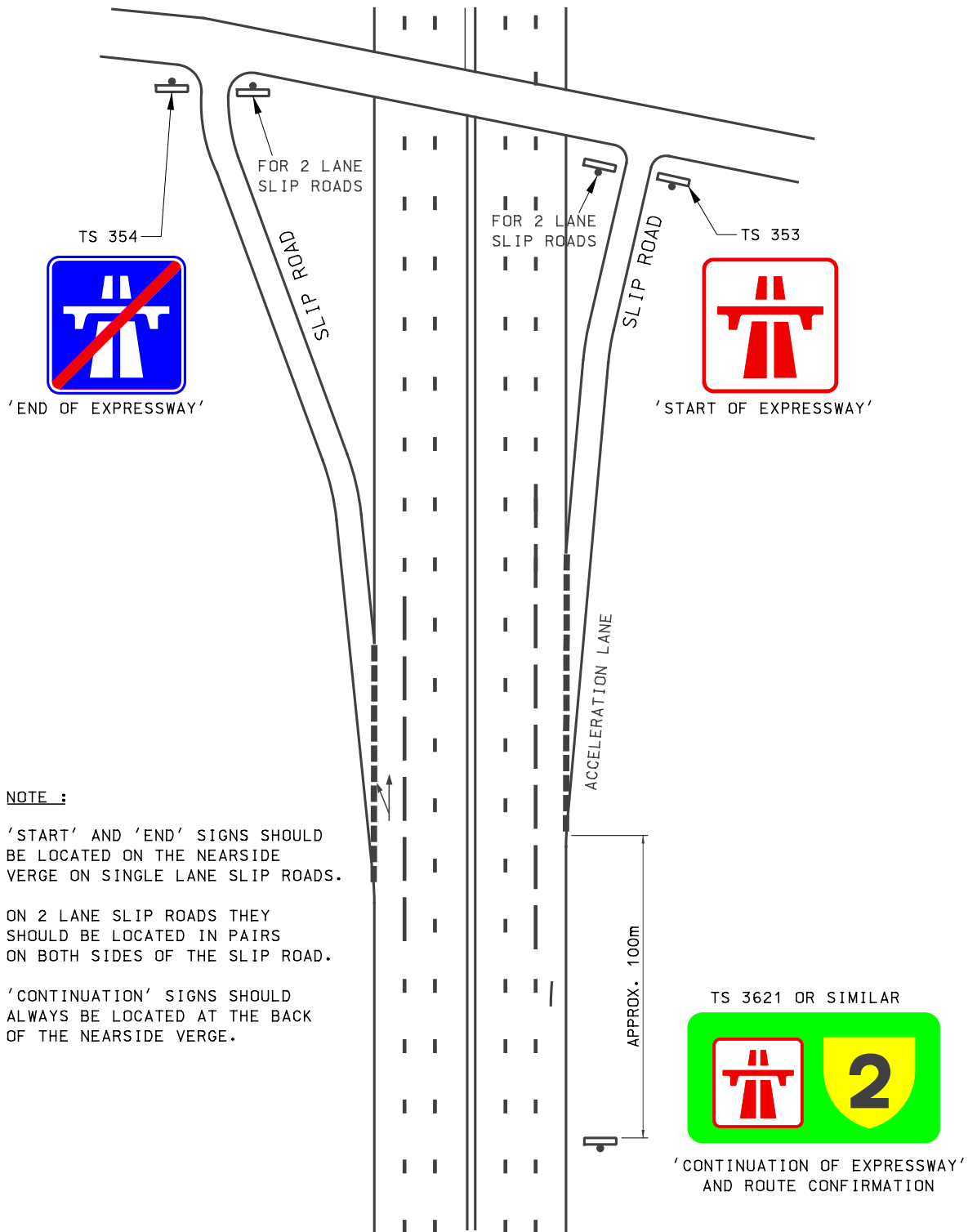
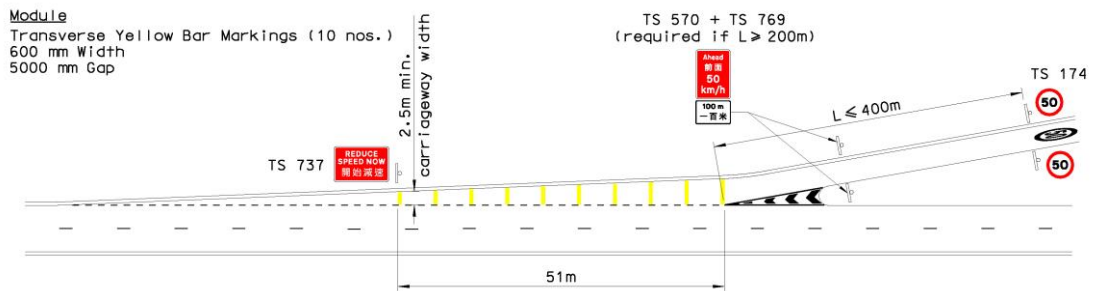
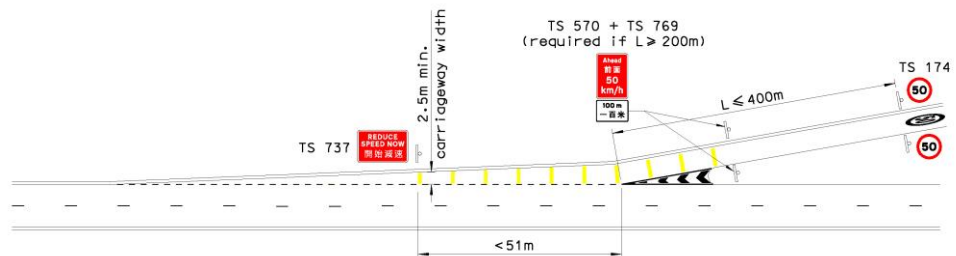

DIAGRAM 6.4.1.3 : WARNING SIGN AND MARKINGS TO ALERT MOTORISTS TO REDUCE SPEED AT SLIP ROADS

(i) NORMAL ARRANGEMENT



(ii) ALTERNATIVE ARRANGEMENT WITH SHORT TAPER LENGTH



(iii) PARALLEL DIVERGING LANE

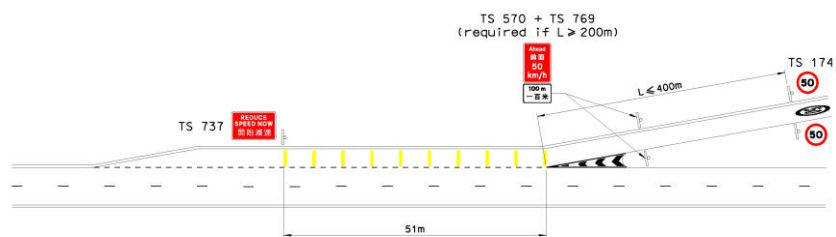

(iv) DIVERGING LANE - LANE DROP ARRANGEMENT

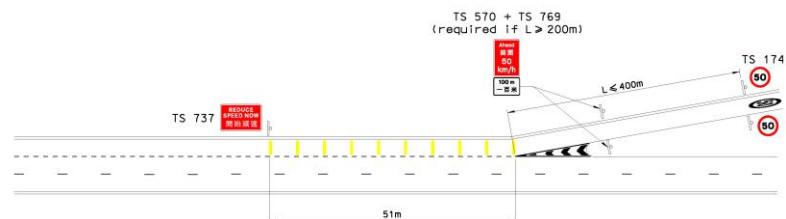

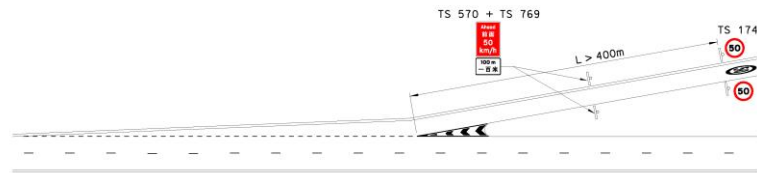
(v) SPEED LIMIT CHANGE For L > 400m (SIMILAR FOR LANE DROP ARRANGEMENT)

- 6.4.1.10 Details on the mounting height of traffic signs and directional signs are given in Sections 2.2.3 and 3.2.4, of Chapters 2 and 3, respectively, of Volume 3. However as pedestrians are not allowed on Expressways, the lower range of mounting heights i.e. 900mm - 1500mm will normally be adopted and, within this range, 900mm is considered to be the safest and most economic and should be adopted wherever possible, as shown in Diagrams 6.4.1.4 to 6.4.1.6.
- 6.4.1.11 The use of galvanised steel sections for sign mountings on Expressways is preferred. Fabrication of individual sign mounting components should be completed before galvanising and the system designed to obviate the need for on site welding, thereby minimising future maintenance work.
- 6.4.1.12 Galvanised sign mountings on Expressways should not be painted. The grey colour of the galvanised coating is acceptable as a finished colour and any attempt to paint it will incur unnecessary future maintenance requirements and costs.
- 6.4.1.13 The erection of specific regulatory traffic signs restricting or prohibiting particular actions will not be necessary providing such restrictions or prohibitions are referred to in the relevant Expressway Legislation. Therefore, for example, traffic signs or road markings relating to no stopping will not be required but speed limit signs will. Additionally the use of traffic sign 216, "Hard Shoulder for Emergency Only" is not necessary as it will not be permitted for vehicles to stop other than in an emergency or to carry out works on any part of the Expressway. The erection of this sign is therefore superfluous and will only create an additional hazard.
- 6.4.1.14 It is particularly important on Expressways that any signs erected along the route are well maintained. Regular inspection and cleaning procedures should therefore be introduced to ensure that signs are always legible and do not constitute a hazard because of the need for some repair.
- 6.4.1.15 Road markings provide a very necessary guidance for traffic along Expressways and it is therefore essential that any faded or worn markings are replaced, as soon as reasonably possible, and if necessary in advance of any general re-marking programme.

DIAGRAM 6.4.1.4 : LOCATION OF SMALL ROAD SIGN

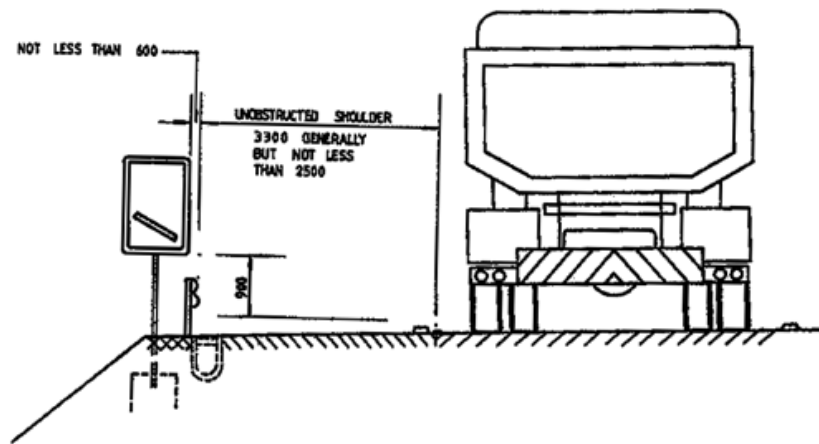

NOT TO SCALE

ALL DIMENSIONS IN MILLIMETRES

DIAGRAM 6.4.1.5: LOCATION OF LARGE ROAD SIGN

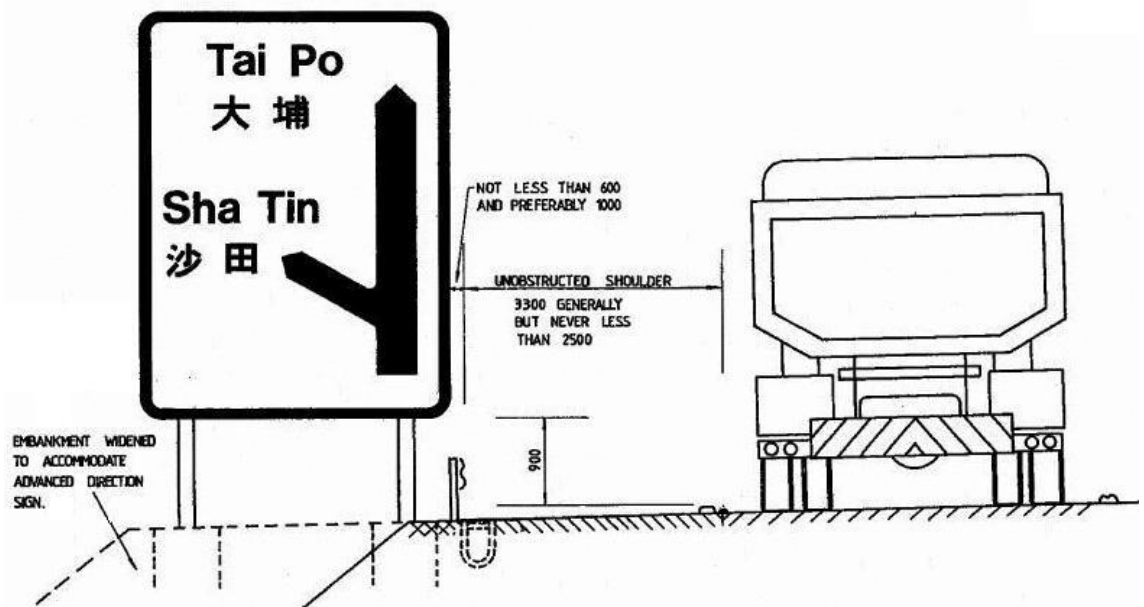

NOT TO SCALE

ALL DIMENSIONS IN MILLIMETRES

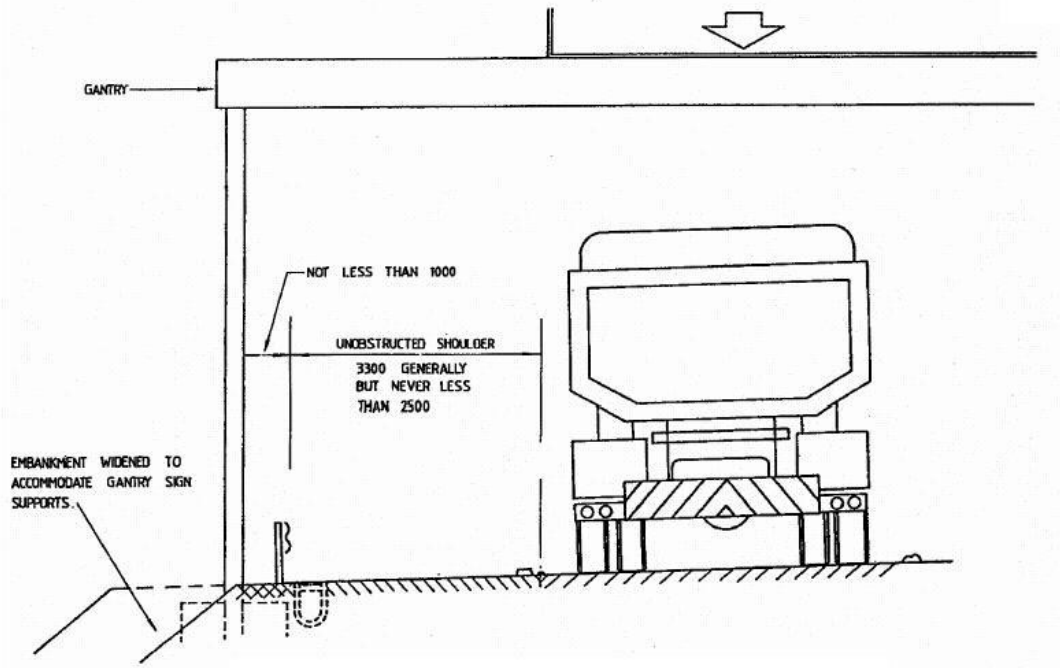
DIAGRAM 6.4.1.6 : LOCATION OF GANTRY SIGN SUPPORTS

NOT TO SCALE

ALL DIMENSIONS IN MILLIMETRES

6.4.2 Directional Signs

- 6.4.2.1 Details of the design format for directional signs along Expressways are given in Chapter 3 of Volume 3, and will be similar to those for Directional Signs along Trunk Roads and Primary Distributor Roads, except that the background colour of expressway signs should be green as opposed to blue on non expressway signs. Details of colour of direction signs is given in Section 3.2.7 of Volume 3.
- 6.4.2.2 Along Expressways it is preferable that wherever possible gantry or overhead cantilever directional signs are used, with the exception of the signing of service areas where gantry signs will seldom be justified. Overhead cantilever and roadside directional signs are therefore appropriate.
- 6.4.2.3 Where roadside signs are used they will, as mentioned before, require the verge to be widened to create sufficient space to accommodate the sign structure. The same may apply to gantry and overhead cantilever signs but to a lesser extent. However it is most important for all types of signs that allowance for the extra land that may be required is made at the design stage, as otherwise the provision of adequate guidance to road users may be prejudiced. The actual width required for this purpose will depend on the particular sign being used, but for roadside signs, widths of 4000mm or more merely for the sign itself are not uncommon. The overall space required for the sign will be greater than just the width of the sign, to allow both, for the necessary clearances, as shown in Diagrams 6.4.1.3 to 6.4.1.5 to be achieved, and any working space that may be required around the sign.
- 6.4.2.4 Although this is a necessity in respect of directional signing for all road types, it is essential with regard to Expressways that care is taken to ensure that directional signs are positioned correctly in relation to the junction to which they refer, and such that they are clearly visible to approaching drivers from the appropriate distance. Table 6.4.2.1 provides information as to the location of signs on Expressways, Table 6.4.2.2 on the minimum clear visibility distance requirements, and Diagram 6.4.2.1 illustrates the visibility envelope necessary for roadside signs. Particular care should be exercised in sag curve situations, where a gantry sign may be obscured by another gantry sign or overbridge.
- 6.4.2.5 Diagram 6.4.2.2 illustrates typical arrangements for gantry and roadside and gantry directional signing but further information on this may be found in Chapter 3 of Volume 3, and should be consulted.

6.4.2.6

To avoid the erection of additional structures and to reduce the possibility of signs being obscured, the use of convenient overbridges should be considered as a possible alternative for mounting overhead signs but due regard must be given to the suitability of the bridge structure for this purpose.

DIAGRAM 6.4.2.1 : VISIBILITY ENVELOPE FOR ROADSIDE SIGNS

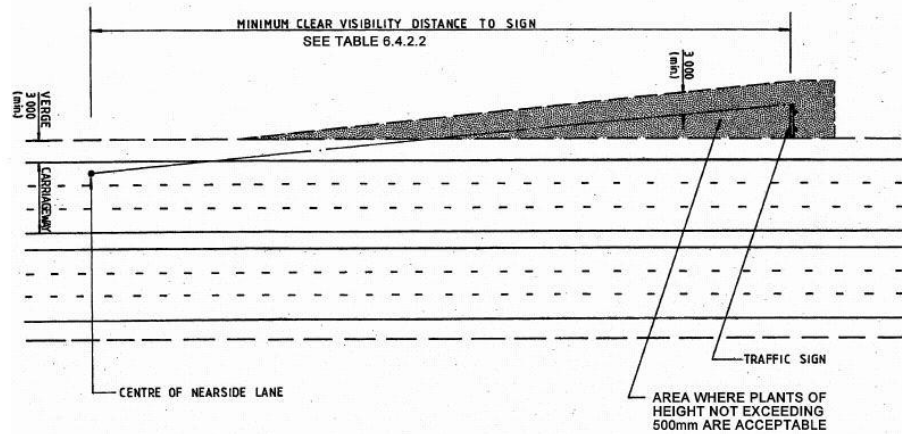

DIAGRAM 6.4.2.2 : DIRECTION SIGN LAYOUT

(a) Layout for Gantry Signs

(b) Layout for Roadside Signs

(Note: Verge widening will usually be required to locate these signs)

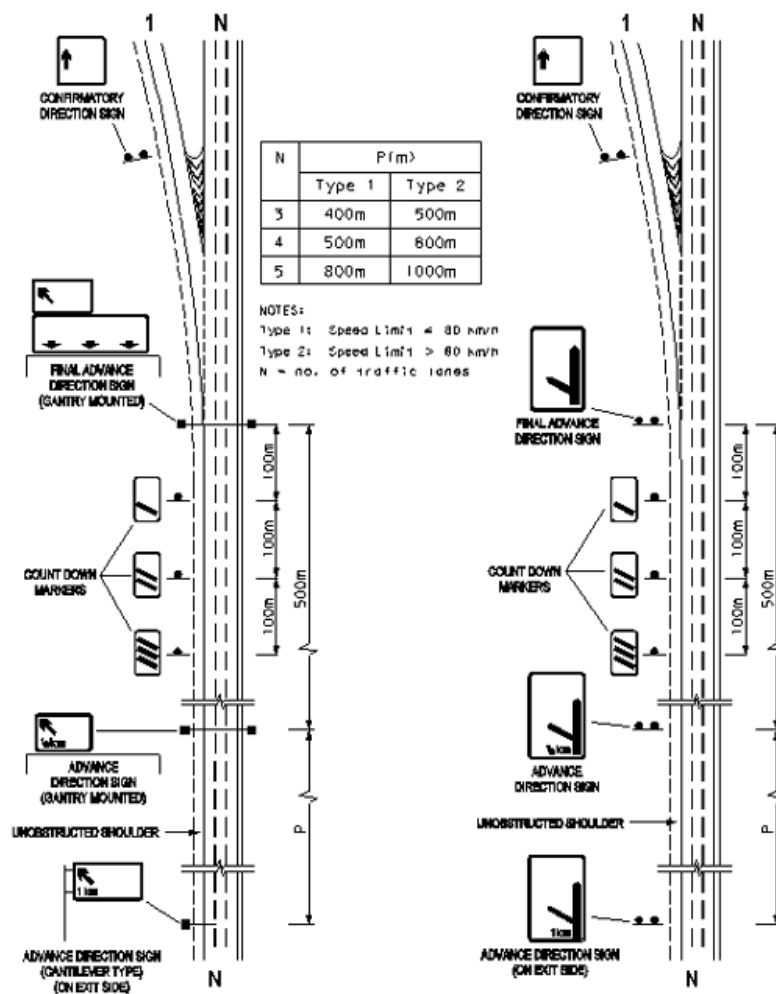

Table 6.4.2.1
Sign Locations

<u>Sign Type</u>		<u>"x"-height</u> (mm)	<u>Location</u>	<u>Illumination</u>
Advance Direction Sign	Cantilever or gantry or Roadside*	250	500m - 1000m ** before start of deceleration lane	Externally illuminated and reflectorised
Countdown Markers	Roadside, (1200mm x 700mm)	-	300m 200m 100m **before start of deceleration lane	Reflectorised
Final Advance Direction Sign	Gantry or Roadside*	250	At start of deceleration lane	Externally illuminated and reflectorised
Confirmatory Direction Sign	Roadside	250	Located near gore	Reflectorised

- * Mixed Cantilever/Gantry/Roadside Signs may be the best method of signing, but once a roadside sign is introduced in the sequence of approach signing, roadside signs must be used for all direction signs in advance of that roadside sign, in that particular sequence.
- ** The exact location depends on the higher design speed and the number of traffic lanes as shown in Diagram 6.4.2.2.

Table 6.4.2.2
Visibility Distances for Directional Signs

<u>Sign Type</u>	<u>Minimum clear visibility distance to sign(m)</u>
Advance Direction Sign	180 (135 for gantry signs)
Final Advance Direction Sign	180
Confirmatory Direction Sign	105

6.4.3 Chainage Markers

6.4.3.1 Expressways which will normally form part of the Strategic Road Network should be provided with chainage markers. Guidelines on the design of and provision of chainage markers are given in Section 3.3.11 of Chapter 3, Volume 3.

6.4.4 Road Markings and Road Studs

6.4.4.1 Reflective hot applied thermoplastic material or its equivalent, in accordance with the current Highways Department Specification, but not road paint, must be used for permanent road markings on Expressways. For temporary road markings, only preformed pavement tapes shall be used.

6.4.4.2 Detailed requirements for road markings are given in Volume 3, Chapter 5 of this manual, but for all Expressways, markings utilised must be based on the assumption of a 70 km/h or more vehicle speed.

- 6.4.4.3 The removal of thermoplastic road marking material from friction course surfacing is virtually impossible using conventional scouring methods, and it will usually be necessary for the whole friction course layer to be removed. Consequently, where road markings have to be altered or removed, consideration should be given to phasing the operation to coincide with the renewal of the friction course surfacing. If this cannot be achieved then areas of the friction course surfacing must be removed and relaid to effectively remove the old markings. Removal of the old friction course in small patches is not acceptable, and resurfacing of a whole lane width is required, except at the edge of the carriageway where it would be acceptable to remove the edgeline by removal and replacement of the friction course over the width of the hard shoulder or marginal strip, as the case may be.
- 6.4.4.4 Because of the difficulty of removing thermoplastic material from the friction course, careful attention must be paid in the initial design as to the road markings proposed, in order to avoid as far as possible, the need to have to remove them at a later date.
- 6.4.4.5 All lane and edge line thermoplastic road markings used on Expressways must be supplemented by road studs with reflective lenses. The studs shall not present any sharp edges to traffic. The reflective portions of the studs shall be free from crevices or ledges where dirt might accumulate. The body which does not form part of the lens of the studs shall be white, silver or light grey in colour.
- 6.4.4.6 Reflective road studs may be of depressible or non-depressible type as described below :
- (i) Non-depressible road stud
A road stud shall be either in the shape of circle having a diameter of not more than 210mm; or rectangle having a length of not more than 210mm and a width of not more than 170mm which shall project not more than 6mm at their edges nor more than 18mm above the road surface, having a unidirectional reflective panel. The reflective panel will usually be coloured either red, amber or green, as they should not normally be used for lane markings.
 - (ii) Depressible road stud (Cats eyes)
A self wiping depressible road stud shall revert to its original form after being traversed by a vehicle. It is approximately 180mm by 140mm and projects not more than 25mm above the road surface. The base of the marker should be made of metal and be strong enough to withstand vehicle loading. A removable housing, usually made of rubber, fitted into the metal base must be able to hold at least two reflective "eyes" to face oncoming traffic which will normally be uni-directional.
- 6.4.4.7 In Expressways, it is desirable to use depressible road studs as far as possible as lane markers.

6.4.4.8 The provision of road studs shall be in accordance with the following :

	<u>Colour of lens/lenses</u>	<u>Colour of body of studs</u>	<u>Spacing</u>
Lane line	White	White	12 or 18m
Warning lane line	White	White	6 or 9m
Left hand edge (only where a hard strip or shoulder is provided)	Red	White	18m
Right hand edge adjacent to central reserve (only where a hard strip is provided)	Amber	White	18m
Across slip road entrance/exit and lay-by	Green	White	4m
Temporary road works	Yellow	Fluorescent saturn yellow	Varies

6.4.4.9 In most situations along Expressways only uni-directional road studs will be necessary. However, if tidal flow operations or similar are envisaged at any location, the road studs must be bi-directional and the reflective lenses of the appropriate colours as viewed by approaching drivers from both directions.

6.4.4.10 The specification for and installation of road studs should be in accordance with the current Highways Department Specification.

6.4.4.11 Road studs and cats eyes must be located as shown in Diagrams 6.3.3.1 to 6.3.3.10.

6.4.4.12 Further information on permanent road studs and their use may be found in Chapter 5 of Volume 3.

6.4.4.13 At road works along an Expressway it is sometimes necessary or advisable to use temporary road studs, to delineate traffic lanes, which are yellow bodied studs with appropriately coloured lenses. Only temporary reflective road studs approved by CHE/R&D shall be used for temporary road works. They shall be designed to be removed without damage to the road surface. Such studs must however conform to the Highways Department Specification.

6.5 Lane and Carriageway Closures

6.5.1 General Requirements

6.5.1.1 All temporary signing, guarding and lighting for lane or carriageway closures in respect of :

- (i) road works;
- (ii) road and horticultural maintenance;
- (iii) road cleansing;
- (iv) traffic control after traffic accidents;
- (v) traffic control in emergency situations; and
- (vi) any other temporary traffic diversion arrangement;

must be carried out in accordance with the *Code of Practice for the Lighting, Signing and Guarding of Road Works*.

6.5.1.2 Guidance for the closure of a lane or lanes of a dual carriageway by means of temporary road signs is given in Fig. 8.1 to 8.5 of the *Code of Practice*.

6.5.1.3 A single lane closure (slow lane) will require similar advance signing to that in Fig. 8.1 to 8.4 of the *Code of Practice* except that the "advanced warning of closure of traffic lane" sign TS 497 would be changed to TS 494. Additionally only the first half of the taper would be required and the line of cones in the parallel section would of course be moved to the edge of the slow lane.

6.5.1.4 In respect of a closure of hard shoulder Fig. 8.5 of the *Code of Practice* illustrates the signing required.

6.5.1.5 The Traffic Console of the Regional Traffic Police Command Centre must always be informed before a lane closure is implemented.

6.5.1.6 Wherever possible and particularly for major works, the Regional Traffic Police should be consulted at least 28 days prior to commencement of the works.

6.6 Maintenance Operations Centres (MOC)

6.6.1 Location and Use

- 6.6.1.1 The patrol, emergency attendance, cleansing and maintenance of the Expressway should be administered from a Maintenance Operations Centre (MOC), conveniently located at or near a grade separated junction on the length of Expressway concerned.
- 6.6.1.2 The length of Expressway that may be administered from one MOC, will depend on the geographical layout and the complexity of the roads in question, but about 40 km may be taken as a guide. Providing the MOC is centrally located the response time for an incident on any part of the Expressway should be under 30 minutes.
- 6.6.1.3 Location at or near a grade separated junction is very important and for reasons of efficiency and economy, it is essential that the junction chosen has four way access to and from the Expressway. Provision of grade separated facilities on the Expressway, specifically for the MOC, may be acceptable but are unlikely to be economically justified.

6.7 Service Areas

6.7.1 Location

- 6.7.1.1 In planning the Expressway system, sites suitable for service areas should be sited at approximately 30 km intervals in respect of both directions of travel.
- 6.7.1.2 Ideally service areas should be provided opposite each other on both sides of the Expressway, with, where possible, an overbridge across the Expressway to allow the connection of rear access roads for use by vehicles servicing the Service Areas, but not the general public, other than perhaps as pedestrians.
- 6.7.1.3 Each service area will require about 3 hectares of land depending on the type of facilities to be provided.
- 6.7.1.4 Each service area will require as shown in Diagram 6.7.1.1, its own separate slip road connections to and from the Expressway which must be designed to the full standard in accordance with Section 6.3 of this Chapter, complete with acceleration and deceleration lanes.
- 6.7.1.5 Where it is not possible to provide service areas in pairs opposite each other consideration should be given to having a single 4 hectare site located adjacent to a grade separated junction. However access to the service area must be able to be provided from a convenient side road or directly from a roundabout, as direct access to a service area from the junction's slip roads is unacceptable.
- 6.7.1.6 In selecting sites, consideration should be given to the availability of sewerage, water, gas, electricity and telephone services and to the proximity of local transport which staff may need.

DIAGRAM 6.7.1.1 : EXPRESSWAY SERVICE AREA

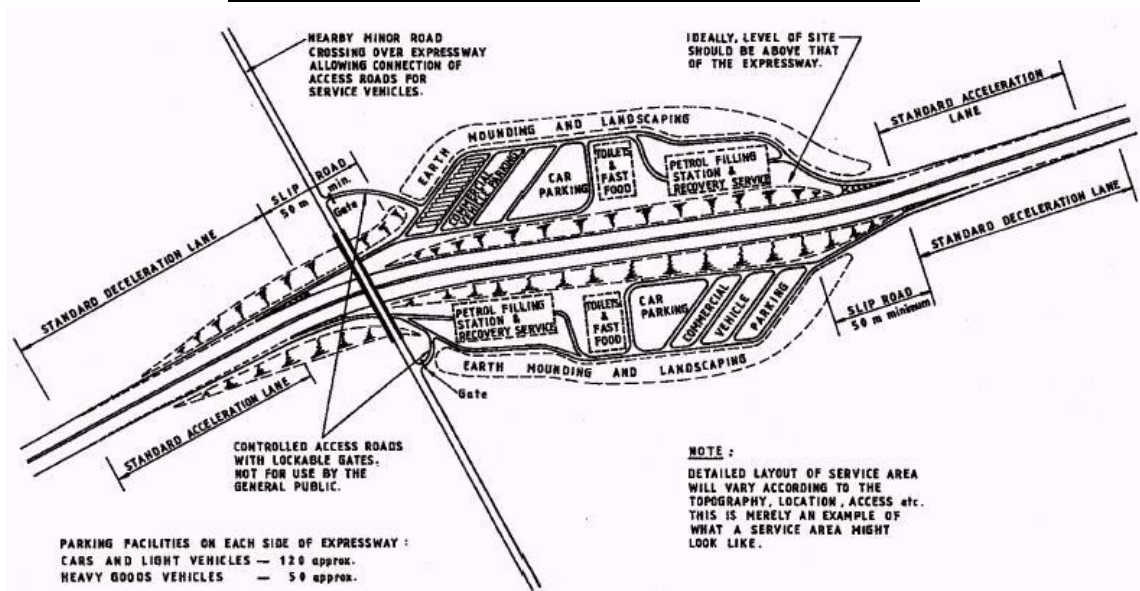

NOT TO SCALE

6.7.2 Facilities

- 6.7.2.1 The facilities provide at each service area may include :
- (i) parking for cars and heavy goods vehicles;
 - (ii) toilets;
 - (iii) fast food facility;
 - (iv) petrol filling station; and
 - (v) vehicle recovery service.
- 6.7.2.2 The petrol filling station, which is essential to all service areas, should be the last facility before traffic rejoins the Expressway.
- 6.7.2.3 Where rear access is provided, see paragraph 6.7.1.2, the access should be for the use of staff vehicles, supply vehicles, emergency service vehicles, breakdown lorries and expressway maintenance vehicles only, and to ensure this the access roads should be closed by means of lockable gates. The general public must not be permitted to use these service roads for vehicular access. However where identical facilities cannot be provided for each opposite service, consideration might be given to using the service road as a pedestrian link.
- 6.7.2.4 Part of the site should be set aside for landscape works to help screen the service area.
- 6.7.2.5 Service Areas should be signed at regular intervals, in advance, to allow drivers to make rational decisions on where they wish to stop. The signface designs for Service Area directional signs are illustrated in Diagram 6.7.2.1, but Chapter 3 of Volume 3 should also be referred to.
- 6.7.2.6 On joining an Expressway where service areas are provided, drivers should be informed of the distance in 'km' to the next service area by appropriate signing as indicated in (i) in Diagram 6.7.2.1. The sign should be placed about 200m beyond the end of the acceleration taper i.e. about 100 m beyond the Expressway confirmation sign, see paragraph 6.4.1.5. The sign should be located at the rear of the hard shoulder or hardened verge.
- 6.7.2.7 Where junctions are closely spaced it is sufficient to have the distance informatory sign, in (i) in Diagram 6.7.2.1, erected only at the far junction of a pair of closely spaced junctions. As a guide in this respect the signs need not be closer to each other than 5 km.
- 6.7.2.8 Where a service road has its own direct access slip roads serving it from the Expressway, signing should be in accordance with the normal junction signing as set down in Chapter 3 of Volume 3, that is, there should be an Advance Direction Sign, $\frac{1}{2}$ km in advance of the service area, a Final Advance Direction Sign at the start of the slip road and a Direction Sign at the nose of the junction. However as explained in Chapter 3, Volume 3, Section 3.5.7, directional signs should only show the direction to the service area and not forward destinations beyond this. Also in terms of the symbols to be used it is not really necessary to include the parking symbol "P" if the refreshment symbol is used, as it can be assumed that parking will be provided.

DIAGRAM 6.7.2.1 : SERVICE AREA DIRECTION SIGNS

(i) **DISTANCE TO SERVICE AREA**



(ii) **ADVANCE DIRECTION SIGN**



(iii) **FINAL ADVANCE DIRECTION SIGN**



(iv) **DIRECTION SIGN**



6.7.2.9

Where a service area is located on a minor road served by a grade separated junction from the Expressway the appropriate symbols for the service area should be incorporated into the directional signs for the junction.

6.8 Operation and Management

6.8.1 Utility Services

6.8.1.1 Expressways should not be used for the location of utility services which are not related to the operation of the Expressway, except of course for services which are essential to the operation of the Expressway such as power cables for the road lighting, and telephone lines for the emergency telephones as well as power and communication cables for traffic surveillance and control facilities.

6.8.1.2 In the event that a non-operational utility service is required to be placed along or across an Expressway consent in writing with justification to allow this must be obtained from the Regional Chief Highway Engineer of Highways Department. Approval should not be given unless :

- (i) it is in the interest of the public for the proposed services to be installed;
- (ii) the installation works would not involve any open cut excavation works within the carriageway or the hard shoulder nor would require any access from the Expressway;
- (iii) the underground services are installed in such a way that it will not be necessary to excavate any part of the carriageway and hard shoulder for future inspection, maintenance or replacement.

6.8.1.3 Additionally such utility services should only be permitted to be laid along adjacent verge. In the situation that non-operational utility services need to be laid across an Expressway beneath the carriageway, their provision should be such that for any future inspection, maintenance or replacement it will not be necessary to excavate any part of the carriageway and preferably any part of the hard shoulder, nor should manholes for these service be permitted in the carriageway and, if possible, not in the hard shoulder either.

6.8.1.4 Where there are existing non-operational services in an Expressway, consideration should be given to their removal or relocation when repairs or alterations are being entertained.

6.8.1.5 Any illegal services encountered within the boundary of the Expressway should be removed as quickly as possible. Such illegal services will generally be a safety hazard and very often produce highway maintenance problems due to their presence.

6.8.2 Activities Affecting Operation

6.8.2.1 Advertisements

It is not appropriate for any advertising or decoration materials to be displayed on or adjacent to an Expressway. In this respect an advertisement must include any sign or device extraneous to the operation of an Expressway, such as :

- (i) decorative lights at Christmas and Chinese New Year or at any other time;
- (ii) business advertisements, including election posters;
- (iii) bunting, flags and drapes for special visits;
- (iv) notice boards and display cubes indicating particular Districts; and
- (v) flower/planting displays, additional to any agreed landscaping requirements.

Advertisements at locations such as junctions, approaches to low bridges or other places where special traffic hazards may exist should be discouraged.

6.8.2.2 Contra-flow Working

From time to time it may be necessary to introduce contra flow working along an Expressway in order to carry out certain maintenance works. It is not appropriate to try to foresee such events by the provision of permanent emergency crossings for this purpose, for the following reasons :

- (i) the precise location will be dictated by the location and extent of any works, which can only be determined at the time the works are required;
- (ii) the length to be provided for the gap in the central reserve is difficult to determine in advance as it will be related to traffic and operating conditions at the time the works are required to be carried out, as a general guide a gap of at least 30m will generally be required but at times this may need to be substantially increased; and
- (iii) the provision of such a large gap at times of non-use, increases the accident potential in terms of vehicles striking any ramped down section of any barrier fence and breaking through into the opposing carriageway.

6.8.3 **Emergency Telephones**

6.8.3.1 Chapter 3 of Volume 10 provides advice on the provision of Emergency Telephones and should be referred to.

6.8.4 **Traffic Control and Surveillance Equipment**

6.8.4.1 A policy has yet to be determined on the use of lane control signals or surveillance equipment for Expressways and therefore where it is considered that such equipment may be advantageous the iTransport Division of the Transport Department should be consulted.

6.8.4.2 Further advice on surveillance methods for such roads will be provided in Volume 10.

6.8.5 **Vehicle Recovery**

6.8.5.1 There is at present no policy regarding the appointment by Government of an authority to be officially responsible for the recovery of vehicles on Expressways except Tsing Ma Control Area, and at present this is left to the individual owners of the vehicles to arrange.